

# SERVICE INSTRUCTION

DATE: September 1, 2006

Service Instruction No. 1042Y  
(Supersedes Service Instruction No. 1042X)

SUBJECT: Approved Spark Plugs

This publication lists spark plugs that are approved and not approved by Lycoming for its piston aircraft engines. Lycoming advises that only those spark plugs listed as approved be used.

## CAUTION

DO NOT DEPEND ON ENGINE MODEL DESIGNATION FOR SPARK PLUG APPLICATION. THE SAME ENGINE MODEL MAY USE SHORT OR LONG REACH SPARK PLUGS. ENGINES WITH LONG REACH SPARK PLUGS ARE IDENTIFIED BY YELLOW PAINT ON THE CYLINDER FINS BETWEEN THE SPARK PLUG HOLE AND THE ROCKER COVERS. ENGINES WITH SHORT REACH SPARK PLUGS HAVE NO IDENTIFYING COLOR. SEE LATEST REVISION OF SERVICE INSTRUCTION NO. 1181. THE REACH CAN ALSO BE DETERMINED BY MEASURING THE DEPTH OF THE THREADED INSERT. LONG REACH THREADED DEPTH IS APPROXIMATELY 5/8 IN., SHORT REACH THREADED DEPTH IS APPROXIMATELY 3/8 IN.

To use the charts on the following pages, first determine the spark plug reach and connector-wire size of your engine. The table below provides a quick reference for locating a chart that lists a specific spark plug reach/connector-wire configuration.

CHART I, Page 2 – Short reach, 5/8-24 wire end  
CHART II, Page 3 – Short reach, 3/4-20 wire end  
CHART III, Page 3 – Long reach, 5/8-24 wire end  
CHART IV, Page 4 – Long reach, 3/4-20 wire end

The letter “A” indicates spark plugs approved for models shown. A dash (-) signifies that spark plugs are neither recommended nor approved by Lycoming for the model.

## NOTE

Spark plug gage must be set at .016-.022 inch. Installation torque for all spark plugs is 420 inch-pounds (35 foot-pounds). Installation torque for 5/8-24 lead nuts is 80-90 inch-pounds and 110-120 inch-pounds for 3/4-20 lead nuts. Always use new gaskets (P/N STD-295) when reinstalling spark plugs.

Lycoming reserves the right to substitute an equivalent plug whenever the plug ordered is not available.

Unison Industries, Inc. has acquired Autolite aircraft spark plug line. This publication lists the new Unison part numbers.

**CHART I**

SHORT REACH 5/8-24  ENGINE MODEL	MASSIVE									FINE WIRE			
	CHAMPION			SL AUBURN			UNISON			CHAM- PION	SL AUBURN		UNISON
	REM 40E	REM 38E	REM 37BY	SR88	SR87	SR86	UREM 40E	UREM 38E	UREM 37BY	REM38S	SR93	SR93P	UREM 38S
O-235-C,-E,-H	A	A	A	A	A	-	A	A	A	A	A	A	A
O-235-N,-P	A	A	A	-	A	-	A	A	A	A	A	A	A
O-235-K,-L,-M	A	A	A	-	A	-	A	A	A	A	A	A	A
O-235-F,-G,-J	-	-	-	-	-	A	-	A	-	A	A	A	A
O-290	A	A	A	A	A	-	A	-	A	A	A	A	A
O-320-A,-E	A	A	A	A	A	-	A	A	A	A	A	A	A
O-320-C	A	A	A	A	A	-	A	-	A	A	A	A	A
O-320-B,-D	A	A	A	-	A	A	A	A	A	A	A	A	A
O-320-H*	A	A	A	A	A	-	A	A	-	A	-	A	A
IO-320-A	A	A	A	A	A	-	A	-	A	A	A	A	A
IO-320-E	A	A	A	A	A	-	A	A	A	A	A	A	A
IO-320-B,-C,-D,-F	A	A	A	-	A	A	A	A	A	A	A	A	A
LIO-320-B	A	A	A	-	A	A	A	A	A	A	A	A	A
AEIO-320-A,-D	A	A	A	-	A	A	A	A	A	A	A	A	A
AEIO-320-E	A	A	A	A	A	-	A	A	A	A	A	A	A
*O-360-A,-C,-F,-J	A	A	A	-	A	A	A	A	A	A	A	A	A
O-360-B,-D	A	A	A	A	A	-	A	-	A	A	A	A	A
*IO-360-A,-C,-D,-J	-	A	A	-	A	A	A	A	A	A	A	A	A
*IO-360-B,-E,-F,-L,- -M	A	A	A	-	A	A	A	A	A	A	A	A	A
HO-360-A,-B,-C	A	A	A	-	A	A	A	A	A	A	A	A	A
*LO-360-A	A	A	A	-	A	A	A	A	A	A	A	A	A
HIO-360-A,-B,-G	A	A	A	-	A	A	A	A	A	A	A	A	A
HIO-360-C,-D	-	A	-	-	A	A	-	A	-	A	A	A	A
LIO-360-C	-	A	A	-	A	A	A	A	A	A	A	A	A
LHIO-360-C	-	A	-	-	A	A	-	A	-	A	A	A	A
AIO-360-A,-B	-	A	A	-	A	A	A	A	A	A	A	A	A
*AEIO-360-A	-	A	A	-	A	A	A	A	A	A	A	A	A
AEIO-360-B,-H	A	A	A	-	A	A	A	A	A	A	A	A	A
VO-360-A,-B	A	A	A	-	A	A	A	A	A	A	A	A	A
*GO-435-C	A	A	-	-	A	A	A	A	-	A	A	A	A
VO-435-A	A	A	-	-	A	A	A	A	-	A	A	A	A
*GO-480-B,-D,-F	A	A	-	-	A	A	A	A	-	A	A	A	A
GSO-480-A,-B	A	A	-	-	A	A	A	A	-	A	A	A	A
IGSO-480	A	A	-	-	A	A	A	A	-	A	A	A	A
*O-540-A	A	A	-	A	A	A	A	A	-	A	A	A	A
*O-540-B	A	A	-	A	A	-	A	A	-	A	A	A	A
*O-540-E,-F,-G,-H	A	A	-	-	A	A	A	A	-	A	A	A	A
O-540-J	A	A	-	-	A	-	A	A	-	A	-	A	A
*IO-540-A,-B,-E,-G, -K,-L,-AB,-AE	-	A	-	-	A	A	A	A	-	A	A	A	A
*IO-540-C	A	A	-	A	A	A	A	A	-	A	A	A	A
*IO-540,-J	A	A	-	A	A	A	A	-	-	A	A	A	A
*IO-540-D,-N,-T	A	A	-	-	A	A	A	A	-	A	A	A	A
*IO-540-K,-L,-AE	-	A	-	-	A	A	A	A	-	A	A	A	A
IO-540-R	-	A	-	-	A	A	-	A	-	-	-	-	-
*IO-540-V	A	A	-	-	A	A	A	A	-	A	-	A	A

\* - May also have 3/4-20 wire end.

**CHART I (CONT.)**

SHORT REACH 5/8-24  ENGINE MODEL	MASSIVE									FINE WIRE			
	CHAMPION			SL AUBURN			UNISON			CHAM- PION	SL AUBURN	UNISON	
IO-540-W	-	A	-	-	A	A	A	A	-	-	-	-	-
AEIO-540-D	A	A	-	-	A	A	A	A	-	A	A	A	A
*AEIO-540-L	-	A	-	-	A	A	A	A	-	A	A	A	A
VO-540-C2A	-	A	-	-	A	-	-	A	-	-	-	-	A
IO-580	-	A	-	-	-	-	-	A	-	-	-	-	-

\* - May also have 3/4-20 wire end.

**CHART II**

SHORT REACH 3/4-20  ENGINE MODEL	MASSIVE								FINE WIRE			
	CHAMPION		SL AUBURN			UNISON			CHAM- PION	SL AUBURN		UNISON
	RHM 40E	RHM 38E	HSR88	HSR87	HSR86	URHM 40E	URHM 38E	RHM38S	HSR93	HSR83P	URHM 38S	
O-320-H	A	A	-	A	A	A	A	A	A	A	A	
*O-360-A,-F	A	A	-	A	A	A	A	A	A	A	A	
O-360-E	A	A	-	A	A	A	A	A	A	A	A	
*IO-360-A,-J	-	A	-	-	A	-	A	A	A	A	A	
*IO-360-B	A	A	-	A	A	A	A	A	A	A	A	
*LO-360-A	A	A	-	A	A	A	A	A	A	A	A	
LO-360-E	A	A	-	A	A	A	A	A	A	A	A	
LIO-360-A	-	A	-	-	A	-	A	A	A	A	A	
*AEIO-360-A	-	A	-	-	A	-	A	A	A	A	A	
*GO-435-C	A	A	-	A	A	A	A	A	A	A	A	
*GO-480-B,-D,-F	A	A	-	A	A	A	A	A	A	A	A	
*O-540-B	A	-	A	A	-	A	-	A	A	A	A	
*O-540-E,-G,-H,-J	A	A	-	A	A	A	A	A	A	A	A	
*IO-540-A,-B,-G,-K,-L, -AE	-	A	-	A	A	A	A	A	A	A	A	
*IO-540-K,-L,-AE	-	A	-	A	A	A	A	A	A	A	A	
*IO-540-C,-N,-T,-V,-W	A	A	-	A	A	A	A	A	A	A	A	
*AEIO-540-L	-	A	-	A	A	A	A	A	A	A	A	
IO-720-A,-B,-C,-D	-	A	-	-	A	-	A	A	A	A	A	

\* - May also have 5/8-24 wire end.

**CHART III**

LONG REACH 5/8-24  ENGINE MODEL	MASSIVE				FINE WIRE
	CHAMPION		SL AUBURN	UNISON	SL AUBURN
	REB37E	REB32E	171	UREB37E	181
IO-320-C1A,-C1B,-F1A	A	-	A	A	A
LIO-320-C1A	A	-	A	A	A
*IO-360-A1B6,-C1A,-C1F	A	-	A	A	A
IO-360-F1A	A	-	A	A	A
*IO-540-E,-J,-K,-P,-R,-AE	A	A	A	A	A
IO-540-M	A	-	A	A	-
*IO-540-R	A	A	A	A	A
*AEIO-540-L	A	A	A	A	A
*TIO-540-C1A,-E,-H	A	A	A	A	A
*IO-580	A	-	A	A	-

\* - May also have 3/4-20 wire end.

**CHART IV**

LONG REACH 3/4-20  ENGINE MODEL	MASSIVE						FINE WIRE						
	CHAMPION		SL AUBURN		UNISON		CHAMPION		SL AUBURN		UNISON		
	RHB 37E	RHB 32E	271	273	URHB 37E	URHB 32E	RHB 36S	RHB 32S	281	291	283	URHB 32S	URHB 36S
*IO-360-A,-C	A	A	A	A	A	A	A	A	A	A	A	-	A
IVO-360	A	-	A	A	A	-	A	-	A	A	-	A	A
HIO-360-E,-F	A	A	-	A	A	A	-	A	-	-	A	A	A
LHIO-360-F	A	A	-	A	A	A	-	A	-	-	A	A	A
TO-360-C,-F	A	A	-	A	A	A	A	A	A	A	A	A	A
TO-360-E	A	A	A	A	A	-	A	-	A	A	-	A	A
LTO-360-E	A	A	A	A	A	-	A	-	A	A	-	A	A
*TIO-360-A	A	A	-	A	A	A	A	A	A	A	A	-	A
TIO-360-C	A	A	-	A	A	A	A	A	A	A	A	A	A
TVO-435-A,-B,-C,-D,-E,-G	A	A	A	A	A	A	A	A	A	A	A	A	A
TVO-435-F	A	A	A	A	A	-	A	A	A	A	A	A	A
VO-435-A,-B	A	A	A	A	A	-	A	A	A	A	A	A	A
GO-480-G1,-G2	A	A	-	A	A	-	A	A	A	A	A	A	A
IGO-480-A	A	A	-	A	A	-	A	A	A	A	A	A	A
GSO-480	A	A	-	A	A	-	A	A	A	A	A	-	A
IGSO-480	A	A	-	A	A	-	A	A	A	A	A	-	A
O-540-9	A	-	A	A	A	-	A	A	A	A	A	-	A
O-540-L	A	A	A	A	A	-	A	A	A	A	A	-	A
*IO-540-E,-G, K,-M,-P,-S	A	A	A	A	A	A	A	A	A	A	A	A	A
*IO-540-J,-R	A	A	A	A	A	-	A	A	A	A	A	A	A
*IO-540-AA,-AC	A	A	-	A	A	A	A	A	A	A	A	A	A
IGO-540-A,-B	A	A	A	A	A	A	A	A	A	A	A	A	A
IGSO-540-A,-B	A	A	-	A	A	A	A	A	A	A	A	A	A
IVO-540-A	A	-	A	A	A	-	A	A	A	A	A	-	A
AEIO-540-L	A	A	A	A	A	A	A	A	A	A	A	A	A
TIO-540-A	A	A	-	A	A	A	A	A	A	A	A	A	A
*TIO-540-C,-K,-W,-AA,-AB,-AF,-AG,-AH,-AJ,-AK	A	A	A	A	A	-	A	A	A	A	A	A	A
*TIO-540-E	A	A	A	A	A	A	A	A	A	A	A	A	A
TIO,LTIO-540-F	A	A	-	A	A	A	A	A	A	A	A	A	A
TIO-540-G,-AE	A	A	-	A	A	-	A	A	A	A	A	A	A
*TIO-540-H	A	A	A	A	A	A	A	A	A	A	A	A	A
TIO,LTIO-540-J,-N,-R	A	A	-	A	A	A	A	A	A	A	A	A	A
TIO-540-S	A	A	A	A	A	A	A	A	A	A	A	A	A
TIO-540-T	A	A	-	A	A	A	A	A	A	A	A	A	A
TIO,LTIO-540-U,-V	A	A	-	A	A	A	A	A	A	A	A	A	A
TIVO-540-A	A	A	A	A	A	A	A	A	A	A	A	A	A
VO-540-A,-B,-C	A	-	A	A	A	-	A	A	A	A	A	-	A
TIO-541-A,-E	A	A	-	A	A	A	A	A	A	A	A	-	A
TIGO-541-E	A	A	-	A	A	A	A	A	A	A	A	-	A
*IO-580	A	-	A	A	A	-	A	-	A	-	-	A	-
IO-720-A,-B,-D	A	A	-	A	A	A	A	A	A	A	A	A	A

\* - May also have 5/8-24 wire end.

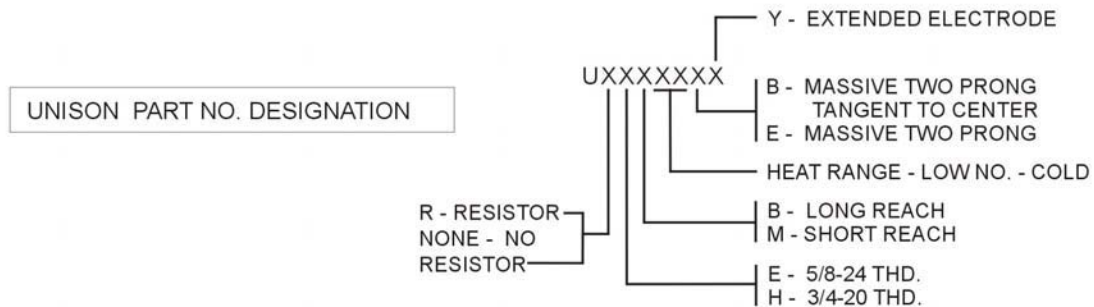
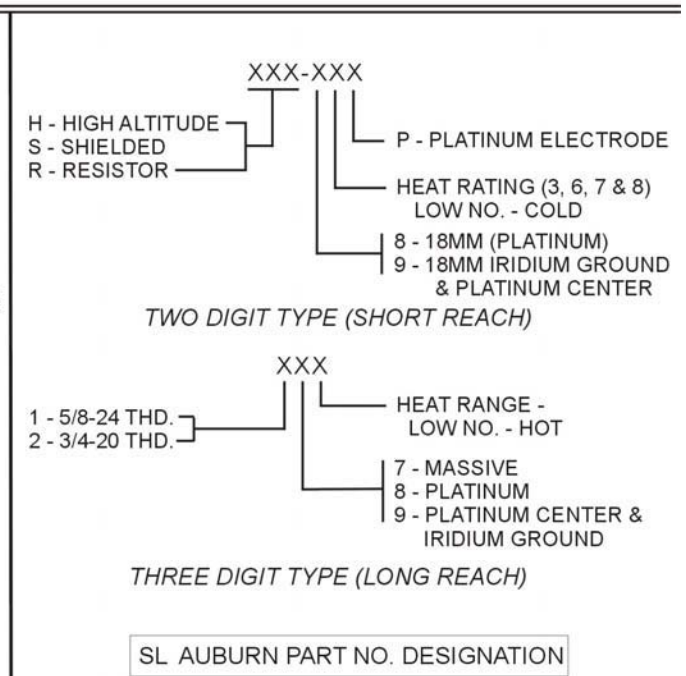
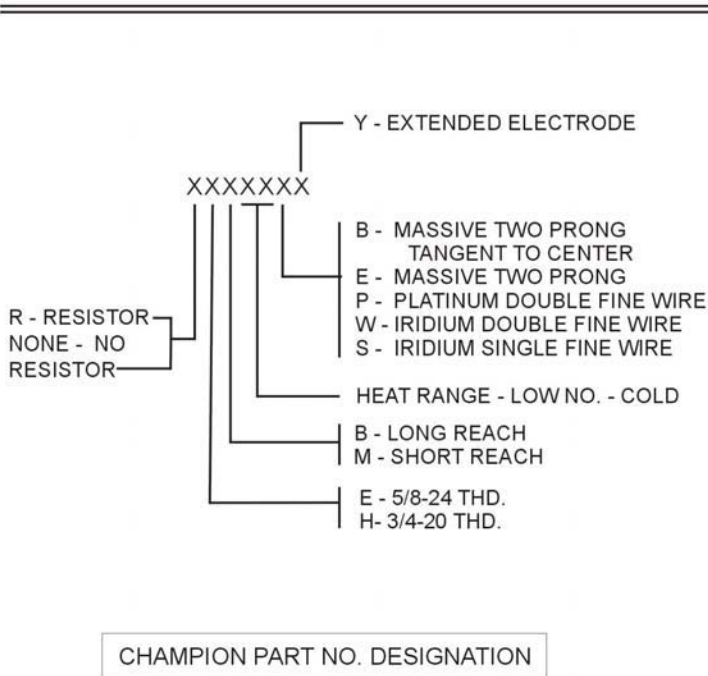
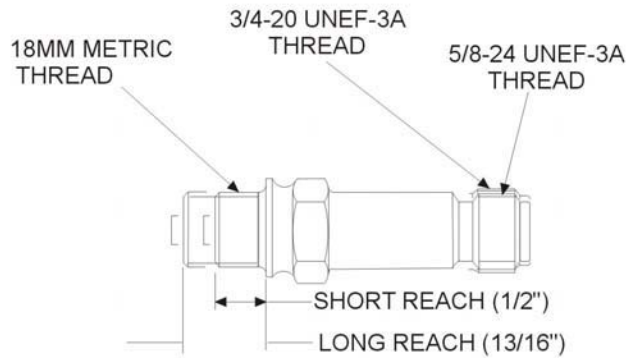
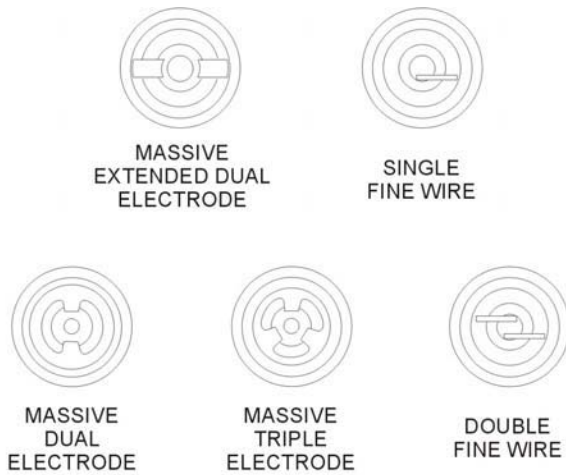

NOTE: Revision "Y" adds engine models, and adds Unison spark plugs.