



A Textron Company

652 Oliver Street
Williamsport, PA. 17701 U.S.A.

Tel. 570-323-6181
Fax. 570-327-7101
www.lycoming.com

SERVICE INSTRUCTION

DATE: February 23, 2009

Service Instruction No. 1524
Engineering Aspects are
FAA DER Approved

SUBJECT: Alternator Bracket Kit for 130A Alternators

MODELS AFFECTED: All Lycoming new, overhauled, rebuilt, or repaired IO-360-A1B6, -B1G6, -C1E6, -C1G6, O-360-A1G6, and TIO-360-C1A6D engines.

TIME OF COMPLIANCE: At the next maintenance event or at annual inspection, whichever occurs first.

Lycoming has determined that a crack may develop in the crankcase near the alternator attaching bracket on any of the above listed engine models utilizing a 130A alternator assembly and only a single alternator attaching bracket. See Figure 1 for the illustrative example. If the existing bracket is drilled for a .375 in. diameter bolt instead of a .4375 in. diameter bolt, contact Lycoming Engines for a replacement bracket.

Oil may be lost through the crack and subsequent damage to the engine may result. Additionally, Lycoming Engines requires cracked crankcases to be replaced before further flight.

The new Alternator Bracket Kit, P/N 05K26328, has been created to supply additional support components to the existing alternator attaching bracket by installing another bracket between the crankcase and alternator. The kit contains the parts listed below to accomplish this modification in the field.

REF FIG	PART NUMBER	DESCRIPTION	QUANTITY
2			
1	07A26130	BRACKET, Alternator - Aft	1
2	LW-31H0.88	BOLT, .3125-18 x .88 in. lg. hex. dr.	2
3	STD-35	WASHER, .3125 in. plain	2
4	AN7-44	BOLT, .4375-20 x 4.59 in.	1
5	STD-713	COTTER PIN, .09 dia. x .75 in. long	1

Safety wire, P/N STD-1823 or equivalent, is also needed to complete the installation.



General Aviation
Manufacturers Association

ISSUED			REVISED			PAGE NO.	REVISION
MO	DAY	YEAR	MO	DAY	YEAR		
02	23	09	--	--	--	1 of 3	--

©2009 by Lycoming "All Rights Reserved"

Lycoming Engines, a division of AVCO Corporation, a wholly owned subsidiary of Textron Inc.

Installation Instructions:

1. Remove the 130A alternator.
2. Visually examine the crankcase for evidence of oil leaks near the existing alternator attaching bracket. If oil is found, confirm that the oil leak is caused by a crack by performing a dye penetrant inspection. If a crack is found, ground the aircraft before further flight and replace the crankcase. If a crack is not found, troubleshoot and repair the source of the oil leak before continuing with Steps 3 through 6.
3. Discard the existing .4375-20 x 4.33 inch long, hex head bolt. In most applications, this bolt will be P/N AN7-42. This bolt will be replaced by P/N AN7-44 which is included in the bracket kit. If the existing bolt is not .4375 in., but instead .375 in., contact Lycoming Engines for bracket replacement.
4. Install the additional bracket kit components #1, #2, and #3 as shown in Figure 2. Torque to 17 ft-lbs. and safety wire the bolts per FAA AC 43.13-1B.
5. Reinstall the 130A alternator.
6. Install the new P/N AN7-44 bolt through the existing alternator bracket, shims, washers, and new bracket P/N 07A26130 and torque to 17 ft-lbs. Install the cotter pin, P/N STD-713 through the castellated nut.

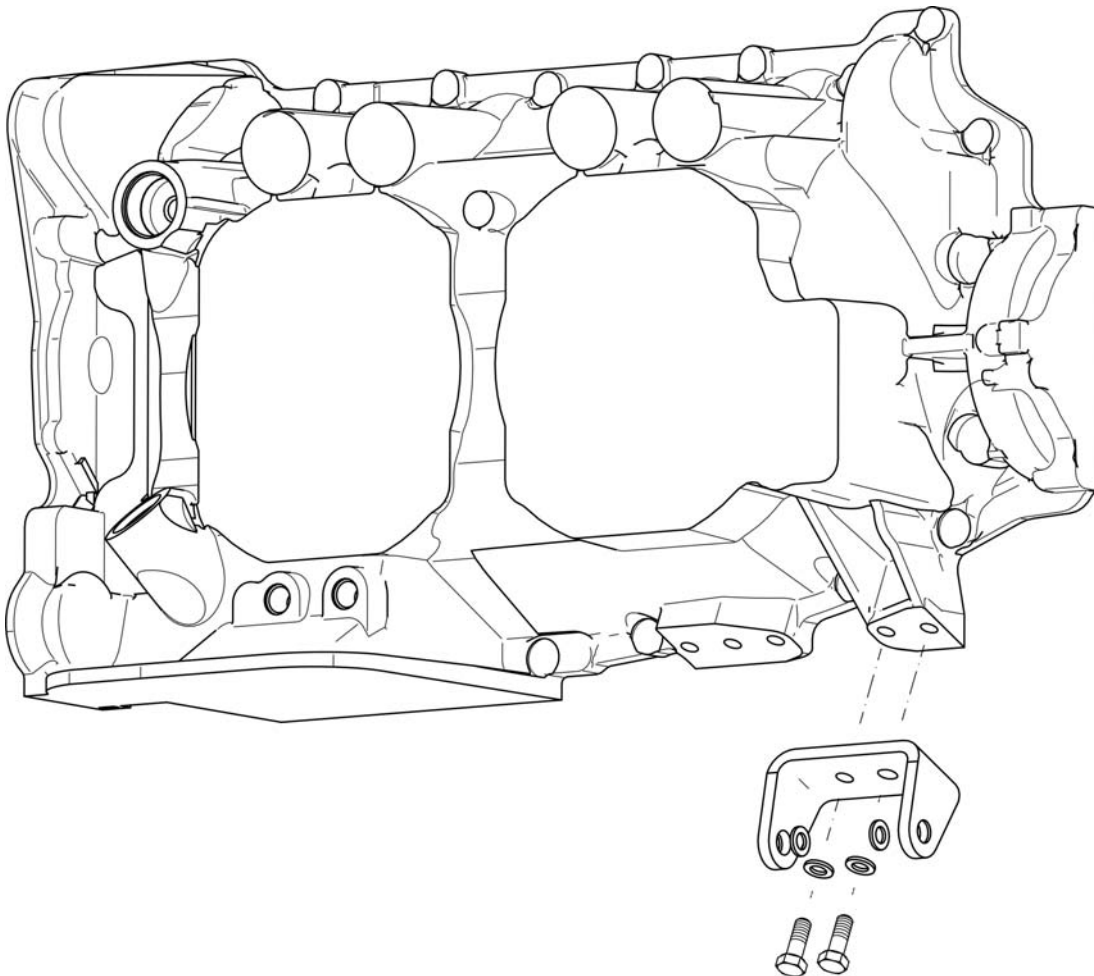

Figure 1: Illustrative Example of Single Alternator Attaching Bracket

ISSUED			REVISED			PAGE NO.	REVISION	S.I. 1524
MO	DAY	YEAR	MO	DAY	YEAR			
02	23	09	--	--	--	2 of 3	--	

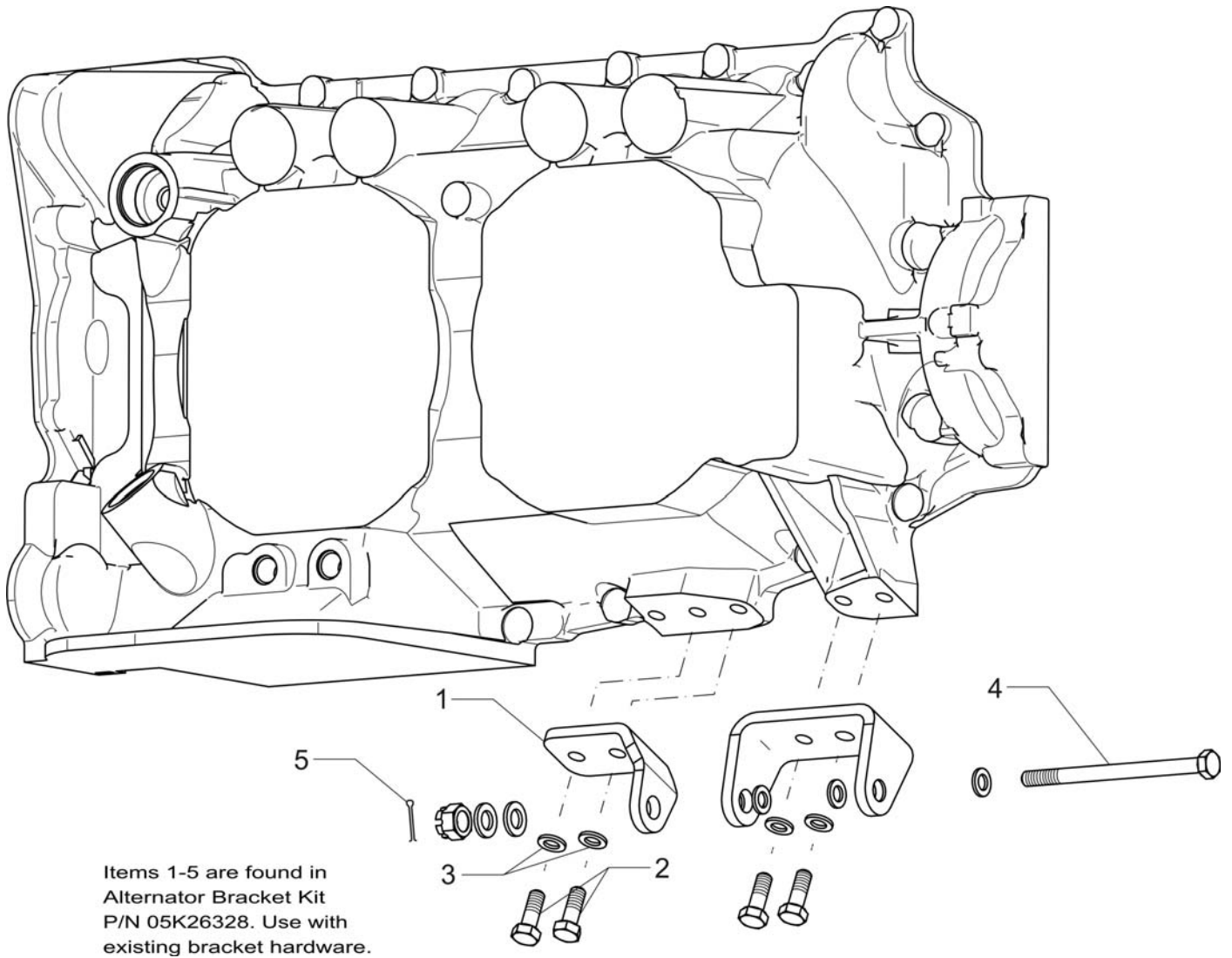

Figure 2. Installation of Additional Support Components

ISSUED			REVISED			PAGE NO.	REVISION	S.I. 1524
MO	DAY	YEAR	MO	DAY	YEAR			
02	23	09	--	--	--	3 of 3	--	