

SERVICE INSTRUCTION

December 13, 2011

Supplement No. 1

To

Service Instruction No. 1535

Counterweight and Roller Removal, Inspection, and Installation

This Supplement No. 1 is being issued to inform owners and operators of the following corrected metric values for Figure 2 Circlip Identification, and Table 4 Gage Dimensions (Figure 4).

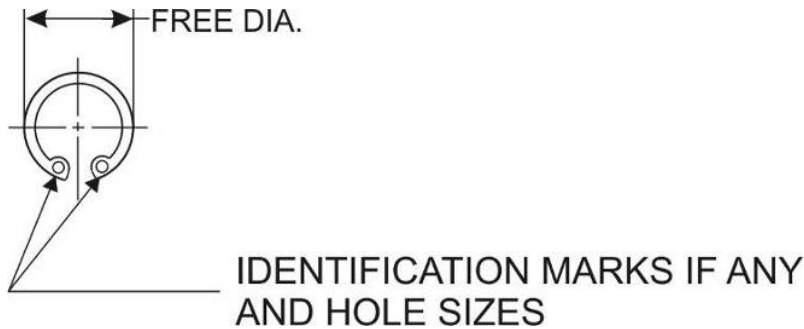

CIRCLIP IDENTIFICATION

FREE DIAMETER		HOLE SIZE		STAMPED MARK	CIRCLIP P/N
in.	mm	in.	mm		
1.031 to 1.056	26.187 to 26.822	0.076 to 0.093	1.930 to 2.362	N/A	LW-14820
1.299 to 1.344	32.995 to 34.138	0.076 to 0.090	1.930 to 2.286	N/A	77005

Figure 2
Circlip Identification

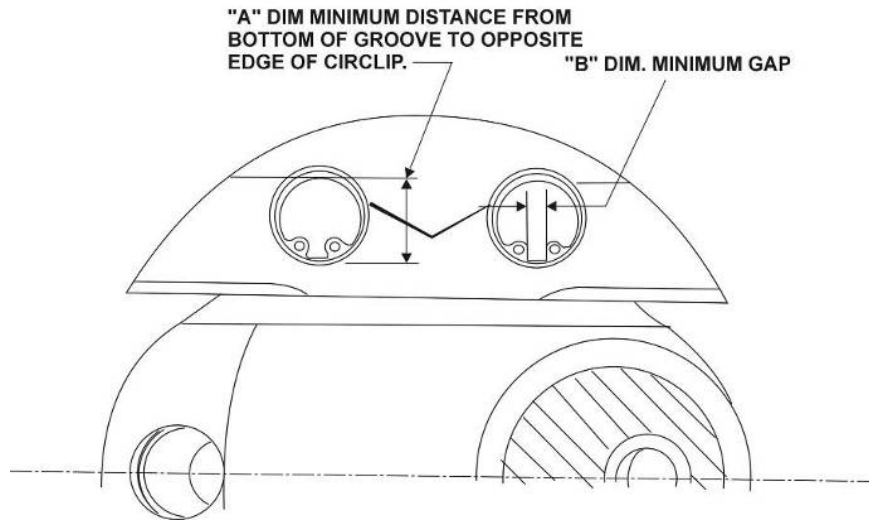

Figure 4
A and B Dimensions

TABLE 4
GAGE DIMENSIONS (FIGURE 4)

Circlip P/N	A Dimension		B Dimension		Gage	Use Gage Detail		APPLICATION
	in.	mm	in.	mm		64892-2	64892-3	
LW-14820	0.892 (-0.000 +0.002)	22.657 (-0.000 +0.051)	0.198 (-0.000 +0.002)	5.029 (-0.000 +0.051)	64892	●		All counterweights
77005	1.132 (-0.000 +0.002)	28.753 (-0.000 + 0.051)	0.245 (-0.000 +0.002)	6.223 (-0.000 +0.051)	64892		●	Only for TIGO-541 engines

ISSUED			REVISED			PAGE NO.	REVISION	S.I. 1535
MO	DAY	YEAR	MO	DAY	YEAR			
10	31	11	--	--	--	2 of 2	Supp. 1	