



652 Oliver Street
Williamsport, PA. 17701 U.S.A.

Tel. 570-323-6181
Fax. 570-327-7101
www.lycoming.com

SERVICE INSTRUCTION

DATE: March 29, 2011

Service Instruction No. 1484C
(Supersedes Service Instruction No. 1484B)
Engineering Aspects are
FAA (DER) Approved

SUBJECT: Installation Torque for Fuel Metering Device, Carburetor, Fuel Injector Servo or “AN” Fuel Pump Hold Down Nuts

MODELS AFFECTED: All Lycoming reciprocating aircraft engines

TIME OF COMPLIANCE: When installing a fuel metering device, carburetor, fuel injector servo or “AN” fuel pump

NOTE

Incomplete review of all the information in this document can cause errors. Read the entire Service Instruction to make sure you have a complete understanding of the requirements.

This Service Instruction includes the steps and torque values for installation of a fuel metering device, carburetor, fuel injector servo or “AN” fuel pump.

1. Refer to the appropriate Parts Catalog for the correct washers, lock washers, nuts, gaskets, and spacers for each application.
2. Ensure that the accessory housing studs are free of dirt and debris and that the threads are not damaged.

INSTALLATION:

1. Apply Castrol Contractor Special NLGI #1 or greases shown in the latest revision of Service Instruction No. 1059, to the drive spline of the fuel pump.
2. Apply Loctite 569 to the threads of the fittings on the AN fuel pumps and torque to the latest revision of SSP-1776.
3. Install the specified washers, lock washers, nuts, gaskets, and spacers as applicable.
4. In a crisscross pattern, tighten the nuts finger tight so the flange of the fuel metering device, carburetor or fuel injector servo unit, or “AN” fuel pump, is flat to the attaching flange. Refer to Figure 1.



ISSUED			REVISED			PAGE NO.	REVISION
MO	DAY	YEAR	MO	DAY	YEAR		
05	04	98	03	29	11	1 of 2	C

Torque the nuts in a crisscross pattern to an **initial** torque value from the table below and then without any lag time, torque the nuts in a crisscross pattern to a **final** torque value from the table below.

Thread Size	Initial Torque	Final Torque
1/4-20	48 in.-lb. (5.4 Nm)	96 in.-lb. (10.8 Nm)
5/16-18	90 in.-lb. (10.1 Nm)	204 in.-lb. (23.0 Nm)

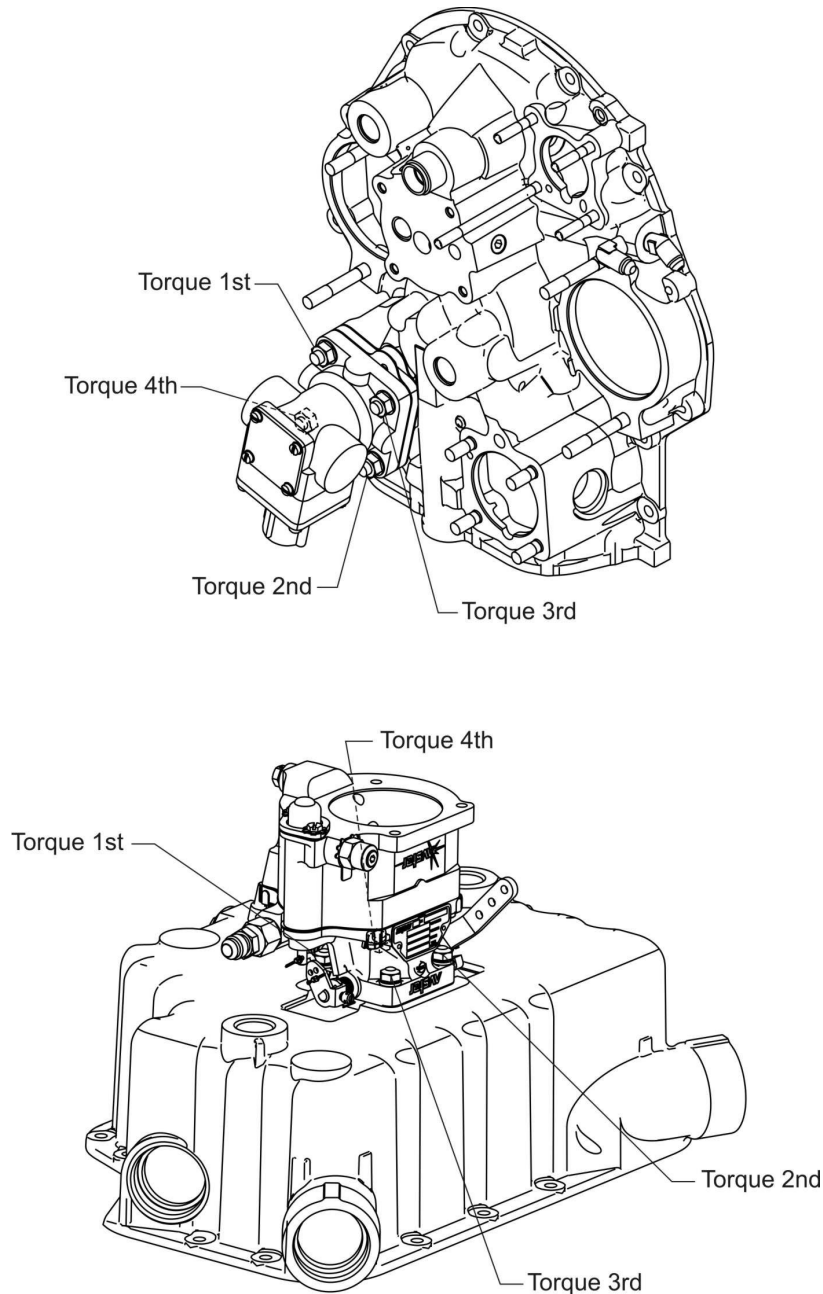

Figure 1
Torque Sequence – Crisscross Pattern

ISSUED			REVISED			PAGE NO.	REVISION	S.I. 1484
MO	DAY	YEAR	MO	DAY	YEAR			
05	04	98	03	29	11	2 of 2	C	