



652 Oliver Street
Williamsport, PA. 17701 U.S.A.

Telephone +1 (877) 839-7878 (U.S. and Canada)
Telephone +1 (570) 327-7222 (International)
Fax +1 (570) 327-7101
Email Technicalsupport@lycoming.com
www.lycoming.com

SERVICE INSTRUCTION

DATE: April 21, 2021

Service Instruction No. 1569B
(Supersedes Service Instruction No. 1569A)
Engineering Aspects are
FAA Approved

SUBJECT: Installation, Operation, and Maintenance of Lycoming Electronic Ignition System (EIS)

MODELS AFFECTED: Lycoming 4 and 6-Cylinder piston aircraft

TIME OF COMPLIANCE: At the owner / operator's discretion.

REASON FOR REVISION: Revised the SUBJECT line. Formatted pages 4 through 18 to indicate separation between Installation, Operation, and Maintenance chapters.
Revised Table 2 – Troubleshooting Guide.

NOTICE: Incomplete review of all the information in this document can cause errors. Read the entire Service Instruction to make sure you have a complete understanding of the requirements.

This Service Instruction provides guidance to remove existing Magneto Type Ignition System and the installation and troubleshooting of the Lycoming Electronic Ignition System (EIS).

This Service Instruction provides Instruction for Continued Airworthiness (ICA) for the EIS. Refer to ICA EIS Ignition System Section in the Maintenance chapter of this Service Instruction.

This Service Instruction, as a standalone document, only provides sufficient approved data for the engine alteration. A subsequent airframe alteration is required when engines modified per this SI are installed into an airframe and connected to the airframe electrical system. The airframe electrical diagrams in this SI are only provided for information and do not constitute an airframe installation approval.

Lycoming recommends that operators and mechanics interested in the installation of Lycoming EIS, review this document and make appropriate decisions prior to beginning any work. These decisions will aid in ordering the appropriate EIS units and help facilitate the return-to-service documentation.

At the engine level, an EIS may be installed replacing one or both of the engine's traditional magnetos as a **minor alteration** documented with an engine logbook entry. Current FAA guidance is that the required airframe electrical system alterations needed for a **single** EIS installation may be accomplished by either minor or major alteration. The installer can decide which type of alteration is best for their application. Lycoming is providing the following recommendations based on this guidance:

1. If the installer considers the airframe alteration a minor alteration, this Service Instruction, FAA Advisory Circular 43.13-1B and 2B, and other Advisory Circulars or applicable information can be referenced in the airframe logbook as acceptable data.
2. If the installer considers the airframe alteration a major alteration requiring an FAA Form 337, this Service Instruction, specific sections, chapters, and paragraphs used from FAA Advisory Circular 43.13-1B and 2B, and other approved instructions can be referenced in Block 8 of the Form 337 as approved data along with the appropriate airframe logbook entry. If the installer does not have sufficient approved data to substantiate the alteration, they should obtain approval of their acceptable data by an Aviation Safety Inspector (field approval) or appropriately rated Designated Engineering Representative.



General Aviation
Manufacturers Association

ISSUED			REVISED			PAGE NO.	REVISION
MO	DAY	YEAR	MO	DAY	YEAR	1 of 18	B
04	08	20	04	21	21		

Replacing **both** magnetos with two EIS units is considered a major alteration **that is a major change to the type design** at the airframe level and would require an airframe type certificate, amended type certificate, or supplemental type certificate approval. When running dual EIS, the second EIS must be connected to a backup power source independent from the aircraft’s electrical system. A backup battery system such as the TCW Technologies™ Integrated Back-up Battery System has been evaluated by Lycoming and found to be acceptable for this requirement.

Refer to Table 1 to select the correct EIS to replace the currently installed magneto(s). Correct EIS depends on whether the magneto(s) being replaced are 4 or 6-cylinder, plain drive or impulse coupled, and the base ignition timing of the engine. Refer to the latest revision of Lycoming Service Instruction 1443 for EIS part numbers. Contact a Lycoming Authorized Distributor to order EIS Modules.

I. General Description

The Lycoming Electronic Ignition System (EIS) is a magneto replacement for 4 and 6-cylinder Lycoming piston aircraft engine.

The EIS is designed to use existing aviation spark plugs gapped to OEM specifications.

The EIS is designed to use a “Slick” style ignition harness. If replacing a “Slick” magneto, the existing serviceable harness may be re-used. If replacing any other magneto, or for a new installation, an approved “Slick” style ignition harness is needed. Although not required, Lycoming recommends installing a new harness when installing an EIS.

 WARNING EIS DIP SWITCHES ARE NOT TO BE CHANGED FROM THE CONFIGURATION SUPPLIED BY LYCOMING. THE PLUG COVERING THE DIP SWITCHES IS FACTORY SEALED AND NOT TO BE REMOVED IN THE FIELD. UNAUTHORIZED CHANGING OF THE DIP SWITCHES COULD CAUSE ENGINE DAMAGE FROM UNKNOWN IGNITION TIMING WHICH MAY RESULT IN UNCOMMANDED LOSS OF ENGINE POWER. UNAUTHORIZED CHANGING OF THE DIP SWITCHES COULD ALSO VOID THE EIS AND ENGINE WARRANTIES.

II. Technical References

The following documents may be referenced during the installation of the EIS:

1. Lycoming EIS Installation Instructions: SI 1569 (this document).
2. The latest revision of Lycoming Service Instruction SI 1443.
3. FAA Advisory Circular 43.13-1B and AC 43.13-2B Acceptable Methods, Techniques, and Practices.
4. Instructions for TCW Technologies™ Integrated Back-up Battery System (if using this battery).

III. Component List

NOTICE: LYCOMING OFFERS THREE MODELS OF THE ELECTRONIC IGNITION SYSTEM. CAREFULLY REVIEW THE FOLLOWING INFORMATION TO DETERMINE THE APPROPRIATE SYSTEM FOR YOUR ENGINE. REFER TO TABLE 1 OF THIS SERVICE INSTRUCTION FOR APPROPRIATE PART NUMBER.

66K4A – 4 Cylinder Lycoming Non-Impulse Magneto Replacement

The following items are needed to install the **66K4A** to an engine:

1. Lycoming Ignition Module: 66K4A (refer to the latest revision of Lycoming Service Instruction SI 1443 for EIS part numbers applicable to your engine),
2. 66K4A Hardware Kit (included with EIS Module),
3. These installation instructions: SI 1569 (available at www.Lycoming.com).

ISSUED			REVISED			PAGE NO.	REVISION	S.I. 1569
MO	DAY	YEAR	MO	DAY	YEAR			
04	08	20	04	21	21	2 of 18	B	

66K4F – 4 Cylinder Lycoming Impulse Magneto Replacement

The following items are needed to install the **66K4F** to an engine:

1. Lycoming Ignition Module: 66K4F (refer to the latest revision of Lycoming Service Instruction SI 1443 for EIS part numbers applicable to your engine),
2. 66K4F Hardware Kit (included with EIS Module),
3. These installation instructions: SI 1569 (available at www.Lycoming.com).

66K6D – 6 Cylinder Lycoming Magneto Replacement

The following items are needed to install the **66K6D** to an engine:

1. Lycoming Ignition Module: 66K6D (refer to the latest revision of Lycoming Service Instruction SI 1443 for EIS part numbers applicable to your engine),
2. 66K6D Hardware Kit (included with EIS Module),
3. These installation instructions: SI 1569 (available at www.Lycoming.com).

Please contact Lycoming if any items are found damaged or missing.

IV. Preparation

1. Find the data-plate on the engine and note the timing value and rotational direction (L or R) listed for the magneto being replaced.
2. Find the matching engine timing value in the table 1 below.

Table 1: EIS Timings

Lycoming Part Number	Description	LED Code	S=Short blink L=Long blink
66K4A3SN-01	4 CYL, PLAIN, 20° FIXED	L-L-L-L	
66K4A3SN-02	4 CYL, PLAIN, 25° FIXED	L-L-L-S	
66K4A3SN-05*	4 CYL, PLAIN, 20° FIXED (With Overspeed Protection)0	S-S-S-S	
66K4F3SN-01	4 CYL, IMPULSE, 20° FIXED	L-L-L-L	
66K4F3SN-02	4 CYL, IMPULSE, 25° FIXED	L-L-L-S	
66K6D3SN-01	6 CYL, 20° FIXED	L-L-L-L	
66K6D3SN-02	6 CYL, 25° FIXED	L-L-L-S	
66K6D3SN-03	6 CYL, 23° FIXED	L-L-S-L	
66K6D3SN-04	6 CYL, 20° FIXED, REV. ROTATION	S-L-L-L	
* 66K4A3SN-05 is installed only on IO-360-C1G6 engine model			

ISSUED			REVISED			PAGE NO.	REVISION	S.I. 1569
MO	DAY	YEAR	MO	DAY	YEAR			
04	08	20	04	21	21	3 of 18	B	

3. Familiarize yourself with the terminals and ports of the EIS:

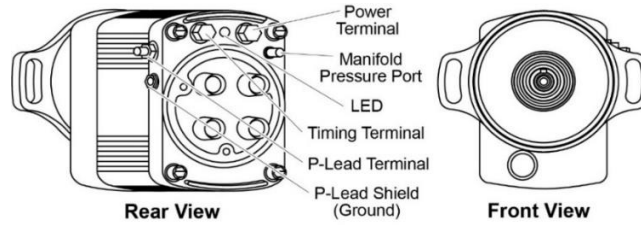

Figure 1: 66K4A Terminals and Ports

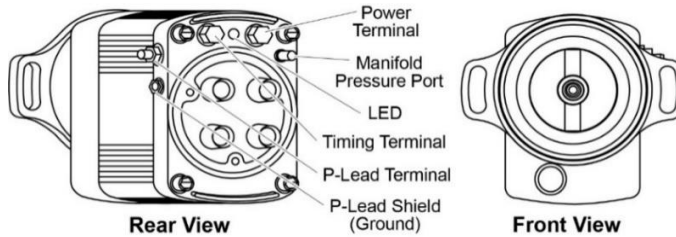

Figure 2: 66K4F Terminals and Ports

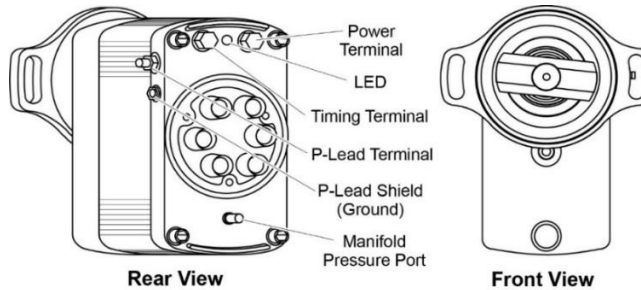

Figure 3: 66K6D Terminals and Ports

INSTALLATION

I. Remove Magneto

1. Label the running p-lead wire connected to the magneto being replaced.
2. Remove the existing ignition harness by removing the screws securing the cap to the magneto.
3. Remove p-lead and ground (if present) from magneto being replaced.
4. Remove magneto from engine by removing the nuts, washers, lock washers, and clamps securing it to the engine. Discard the clamps and lock washers. Examine the nuts and washers for damage and wear, replace as necessary.
 - For **66K4F** or **66K6D** installations ONLY, if present an impulse spacer P/N 61666 **WILL** be re-used. Do not remove the spacer from the engine unless replacement of the engine-to-spacer gasket is planned (this gasket is not included). If the spacer is removed or the engine-to-spacer gasket is damaged, clean and reinstall the spacer with a new engine-to-spacer gasket.
 - For **66K4A** installations ONLY, if present an impulse spacer P/N 61666 **WILL NOT** be re-used. Remove the spacer from the engine and discard.
5. Remove and discard the magneto gasket and clean all gasket residue from the mounting surface. The EIS is sealed with an O-ring (supplied with the EIS) and a gasket is not required.

NOTICE: For turbocharged engines equipped with pressurized magnetos: Lycoming EIS units do not require pressurization. When a pressurized magneto is replaced with an EIS unit, the pressurization source must be sealed using appropriate AN/MS quality caps or plugs as close to the pressurization source as possible. Remove unnecessary pressurization hose assemblies.

ISSUED			REVISED			PAGE NO.	REVISION	S.I. 1569
MO	DAY	YEAR	MO	DAY	YEAR			
04	08	20	04	21	21	4 of 18	B	

II. Remove and Inspect Drive Interface

For 66K4A and 66K4F Installations

1. Remove cotter pin, nut and washer and extract drive gear from magneto.
2. Inspect drive gear per the Drive Gear Inspection procedure.
3. If drive gear is out of specifications, discard and replace with an airworthy drive gear and proceed.
4. If drive gear is within Drive Gear Inspection specifications, proceed to Section III.

For 66K6D Installations

1. Remove the magneto drive interface by gently and carefully pulling it out of the engine magneto cavity.
2. Inspect drive gear per the Drive Gear Inspection procedure.
3. If drive gear is out of specifications, discard and replace with an airworthy drive gear and proceed.
4. If drive gear is within the specifications of the Drive Gear Inspection, proceed.
5. Inspect magneto drive cushions and retainer per the Drive Gear Inspection procedure.
6. If magneto drive cushions and retainer are within the Drive Gear Inspection specifications, proceed to Section III.

Drive Gear Inspection

1. Examine the gear for evidence of pitting and excessive wear. Pits are cause for gear rejection.
2. Examine the involute of the teeth for pitting. Pits are cause for gear rejection.
3. Examine the gear surface for scratches. Scratches are cause for gear rejection. Minor abrasions can be dressed with a fine abrasive cloth.
4. Examine drive gear interface surfaces for signs of wear, pitting, scratches, or cracks. Damage is cause for gear rejection. Minor abrasions can be dressed with a fine abrasive cloth.
5. Examine the bearing for wear, galling, rough balls, and races. Do not reuse any bearing that shows indication of severe wear or uneven running.

III. Install Drive Interface

For 66K4A and 66K4F Installations

NOTICE: The drive gear fits on the EIS shaft in one of two orientations. A normal installation will align a gear tooth valley with the woodruff key on the EIS shaft (Figure 4). If you have difficulty timing the EIS to the engine in further steps, it may be necessary to remove the drive gear from the EIS and re-install it 180° on the shaft as shown in the alternate orientation (Figure 5).

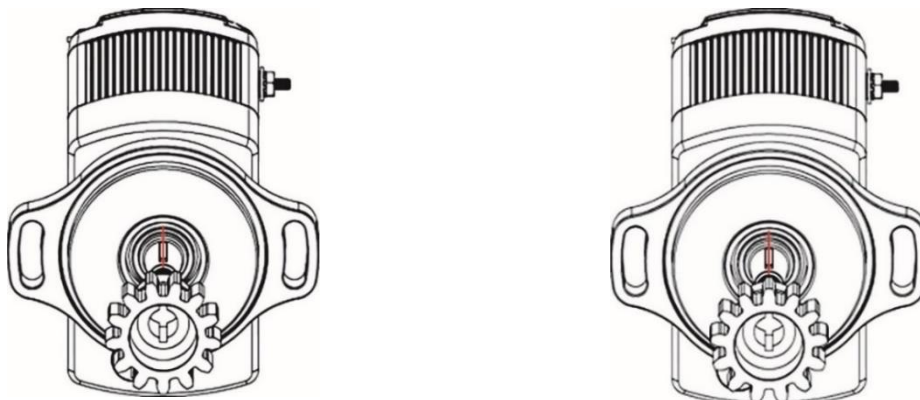

Figure 4: Normal Drive Gear Orientation Figure 5: Alternate Drive Gear Orientation

1. Apply a light coat of C5-A Copper-Based Anti-Seize compound or equivalent to the tapered section of the EIS driveshaft.
2. Install the drive gear (magneto gear) on the EIS driveshaft in the normal orientation (Figure 4).
3. Remove excess anti-seize compound from the EIS driveshaft.

ISSUED			REVISED			PAGE NO.	REVISION	S.I. 1569
MO	DAY	YEAR	MO	DAY	YEAR			
04	08	20	04	21	21	5 of 18	B	

4. Place washer under castellated nut and thread nut onto shaft.
5. Torque the castellated nut to 120 to 180 in.-lbs. (14 to 20 Nm). Tighten to align the castellated nut to the hole in the shaft. Do not exceed 250 in.-lbs. (28.3 Nm).

NOTICE: Refer to the applicable engine parts catalog for appropriate cotter pin part number.

6. Install a new cotter pin through the castellated nut. Bend the short prong down and the long prong up. Trim the long prong flush or below the end of the shaft (Figure 6).
7. Discard the trimmed end of the cotter pin to avoid the possibility of FOD.
8. Ensure locked cotter pin end does not extend beyond the forward face of the drive gear.

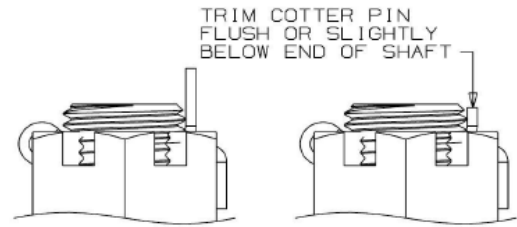

Figure 6: Install the Cotter Pin

For 66K6D Installations

1. Clean the drive interface of debris
2. Install the drive interface in the same manner it was removed from the engine as described in Section II under “For 66K6D Installations”.
3. Engage the magneto drive gear teeth into the engine gear teeth so that the magneto drive cushions align as close to vertical as possible.

NOTICE: The EIS’s final mounting orientation is largely determined by the orientation of the magneto drive cushions. The drive gear teeth may have to be skipped over the engine gear teeth to accommodate a better EIS mounting orientation.

IV. Set Engine to #1 TDC

1. Remove one spark plug from #1 cylinder and discard the spark plug gasket.
2. Turn the crankshaft to find top dead center (TDC - 0°) of #1 cylinder on the compression stroke.

V. Internally Time EIS

1. You must internally time the EIS to align the drive gear before installing the EIS into the engine.
2. Connect a temporary source of positive (+) 8.5 – 30VDC power to the terminal labelled TIMING on the EIS using the provided screw. Finger tighten the screw.
3. Ground the EIS to the negative (-) lead of the temporary power source. Do not attempt to ground through painted or anodized surfaces – ground through the machined mount face, p-lead shield terminal or case bolt heads.
4. The EIS LED should illuminate green. If not, wiggle the drive gear, re-ground the EIS and ensure the EIS p-lead terminal is not grounded.

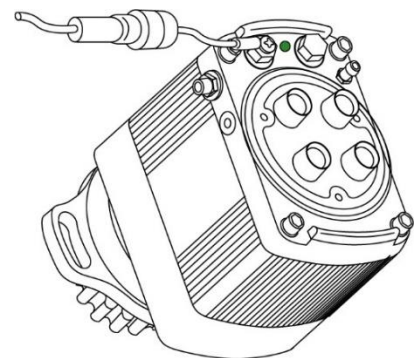

Figure 7: Internally Timed EIS

NOTICE: The EIS LED will not turn on if the p-lead terminal is grounded.

5. Slowly rotate the EIS drive gear to find the point where the LED goes off.
6. **TURN SLOWLY – the LED alignment point has a ½° window and is difficult to see if turning fast!**
7. The point at which the LED goes off is the EIS’s internal TDC alignment.
8. **Once this point is found, care should be taken to avoid any rotation of the EIS drive gear during further steps of engine installation.**

ISSUED			REVISED			PAGE NO.	REVISION	S.I. 1569
MO	DAY	YEAR	MO	DAY	YEAR			
04	08	20	04	21	21	6 of 18	B	

| VI. Mount EIS to Engine

⚠ CAUTION LYCOMING EIS UNITS ARE PROPRIETARY TO LYCOMING. USE ONLY APPROVED DOCUMENTATION SUPPLIED BY LYCOMING FOR THE INSTALLATION AND CONTINUED AIRWORTHINESS OF LYCOMING EIS UNITS.

NOTICE: UNLIKE A MAGNETO, THE LYCOMING EIS IS TIMED (SYNCED) TO #1 CYLINDER COMPRESSION STROKE TDC (0°).

The EIS operates by syncing its internal TDC alignment point to #1-cylinder compression stroke (TDC – 0°).

1. **Confirm the engine is at top dead center (TDC - 0°) of #1 cylinder on the compression stroke.**
2. Ensure the O-ring is present, free of debris and seated in the EIS face groove.
3. Apply Lubrico® M-6 grease or equivalent to the mating surface of the EIS flange and the O-ring.
4. Ensure the EIS is still internally timed as described in Section V above.

NOTICE: When installing a fixed timing EIS, make sure the manifold pressure port (Figures 1, 2, and 3) is not obstructed and open to atmospheric pressure.

5. **Without allowing the EIS drive gear to rotate**, align the EIS mounting ear slots with the engine studs and slide the EIS into the magneto cavity.
6. Hold the EIS flush to the engine, clock the EIS to ensure the point when the LED goes off is within the rotational sweep limits of the mounting ear slots.
7. Repeat steps 4 through 6 above if unable to find the point when the LED goes off as the EIS drive gear may have skipped a tooth over the engine gear when pushed in.

NOTICE: For 66K4A and 66K4F installations, continue with steps 8-13. For 66K6D installations, do not complete step 8, and continue to complete steps 9-13.

8. If **still unable** to find the point when the LED goes off, reinstall the drive gear to the alternate drive gear orientation as described in Section II and begin over from Section V step 1.

NOTICE: In the next step use the referenced Lycoming part numbers or AN/MS equivalent.

9. Install flat washers (P/N STD-1727), lock washers (P/N STD-475), & nuts (P/N STD-410) on to the engine studs over the EIS's slotted mounting ears. Do not re-use lock washers – install NEW lock washers.
10. **Do not use the clamps that some magnetos are installed with.**
11. Finger tighten the nuts, do not allow the EIS to rotate.
12. If necessary, rotate the EIS to ensure the LED stays off. At this point the EIS is timed (synced) to the engine.
13. Torque the mounting nuts, alternating between the nuts in 4 ft.-lb. (5 Nm) increments, to 15 to 18 ft.-lbs. (20 to 24 Nm) ensuring the LED stays off.

| VII. EIS Timing Check

1. Turn the crankshaft counter to normal rotation 1/8 of a turn from #1-cylinder TDC.
2. Slowly rotate the crankshaft in the normal direction.
 - If the LED goes off more than 2° before or after #1-cylinder TDC, the EIS is incorrectly timed and is not in sync with the engine. Loosen the EIS mounting nuts and re-clock the EIS per Section VI step 6 through Section VI step 13.
 - If the **LED goes off as #1 cylinder reaches TDC – 0°** (compression stroke) the EIS is correctly timed (synced) to the engine and you may proceed.

NOTICE: If installing two EIS modules, the LED on both the left and right EIS should go off within 1 1/2° of each other to ensure both EIS modules are correctly timed to the engine.

3. Apply torque seal to the mounting nuts after the EIS is correctly timed.

ISSUED			REVISED			PAGE NO.	REVISION	S.I. 1569
MO	DAY	YEAR	MO	DAY	YEAR	7 of 18	B	
04	08	20	04	21	21			

VIII. Connect EIS to Permanent Power Source, and Airframe Installation Instructions

This section provides for the connection of an EIS to a permanent power source. Connect permanent electrical power from the airframe to the EIS. All components and practices in this section must be in accordance with AC 43-13-1B & 2B or international equivalent.

Operation

The EIS requires a constant, external supply of 8.5 – 30VDC power to operate. Operating current requirements @ 2700RPM.

⚠ CAUTION AIRFRAME SUPPLY VOLTAGE OUTSIDE THE SPECIFIED RANGE CAN RESULT IN ROUGH ENGINE OPERATION. IF THIS OCCURS, CONTACT LYCOMING CUSTOMER SUPPORT.

Model:	@ 14VDC	@ 28VDC
66K4A	0.7±0.2A	0.35±0.2A
66K4F	0.7±0.2A	0.35±0.2A
66K6D	1.0±0.2A	0.5±0.2A

The EIS grounds through the engine.

When turned off (EIS p-lead grounded), an EIS goes into standby and will continuously draw less than 1mA in this mode.

Lycoming recommends keeping the aircraft battery on a maintenance charger when not in use for extended periods of time (1 month or more).

Component List

The following items are needed to install an EIS-modified engine onto an airframe:

- Appropriately sized power wire,
- Fuse holder with 10A fuse (or other appropriate aviation grade 10A circuit protection device) (1 per each EIS).
- Appropriately sized ring terminals,
- Placard,
- These installation instructions.

Power Requirements

- The airframe must be equipped with a 12-Volt battery having a minimum capacity of 20AH or a 24-Volt battery having a minimum capacity of 8.5AH.
- If operating (2) EIS units on the same engine, the second EIS must be hooked up to backup or second power source of at least 2.5 AH, that can be charged by the aircraft main bus.
(NOTE: A TCW Integrated Back-Up Battery System meets this requirement)

Power Wire Requirements

- The EIS requires at a minimum 8.5 volts and 0.7A continuous at the power terminal to the EIS. Wire gauge should be determined based on wire run length in accordance with AC 43.13-1B chapter 11 and a 10A peak instantaneous power draw for the final installation into the aircraft taking into account momentary power draws due to starting or load sharing,
- The EIS power wire must be MIL-Spec (MIL-W-22759 / M22759 / SAE AS22759),
- The EIS power wire must be circuit protected at 10A.

Connecting EIS to Permanent Power Supply

Each EIS must be permanently connected to either:

- Aircraft master solenoid battery positive (+) terminal.
- In series with an Integrated Back-Up Battery System and the aircraft main bus.

ISSUED			REVISED			PAGE NO.	REVISION	S.I. 1569
MO	DAY	YEAR	MO	DAY	YEAR	8 of 18	B	
04	08	20	04	21	21			

Circuit Diagram for the normal EIS installation is shown below.

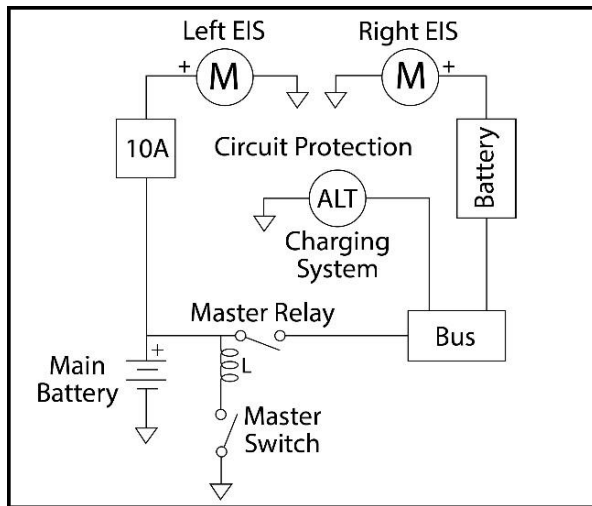

Figure 8: Normal EIS Installation

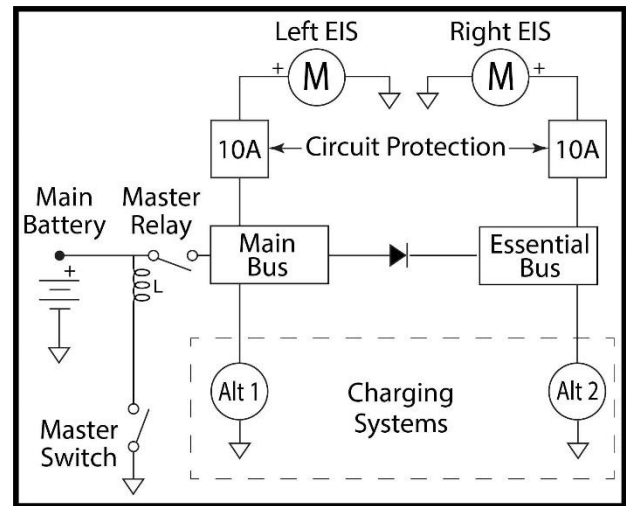

Figure 9: Dual Bus EIS Installation

1. Remove the temporary power source from the TIMING terminal of the EIS.
2. Connect a permanent source of positive (+) 8.5 – 30VDC power to the POWER terminal of the EIS using the provided screw.
3. Tighten the screw to 10±2 in.-lbs. (1.1±0.2 Nm).

NOTICE: The wire connecting the EIS to the permanent power source should be in accordance with guidance outlined in FAA Advisory Circular 43.13-1B, circuit protected at 10A and as short as possible.

4. Route the power wire from the power source to the EIS following the shortest course.
5. Locate the 10A fuse (or other appropriate 10A circuit protection device) as close to the power source as possible.
6. Secure the wire along its entire route, protect from chafing and provide strain relief across areas of movement. Guidance for wire routing, chafe protection and strain relief can be found in FAA Advisory Circular 43.13-1B Chapter 11-137 & 11-138
7. Strip both ends of the power wire and crimp appropriately sized ring terminals onto each end. Do not use solder terminals.
8. Connect the ring terminals per the circuit diagram in Figures 8 or 9 as illustrated in Figure 10.
9. The EIS grounds through the engine. Ensure the negative (-) lead of the permanent power source is connected to the engine.

IX. Install Ignition Harness

- The EIS is designed to use a “Slick” style ignition harness.
- If replacing a “Slick” magneto, the existing harness may be re-used.
- If replacing any other magneto, or for a new installation, an approved “Slick” style ignition harness is needed.
- Although not required, Lycoming recommends installing a new harness when installing an EIS.
 1. Confirm the correct harness is being used and is free of defects.
 2. Install the harness onto the EIS using the Harness Screws.
 3. Torque the screws to 18±2 in.-lbs. (2.0±0.2 Nm).

ISSUED			REVISED			PAGE NO.	REVISION	S.I. 1569
MO	DAY	YEAR	MO	DAY	YEAR			
04	08	20	04	21	21	9 of 18	B	

X. Install P-Lead

1. Install the p-lead wire from the ignition switch onto the EIS p-lead terminal.
2. Thread provided nut over EIS p-lead terminal. Back p-lead base nut with a wrench and torque the nut to 15±2 in.-lbs. (1.7±0.2 Nm).
3. If the p-lead wire is shielded, connect the shield to the p-lead shield (ground) terminal with the provided screw and torque to 15±2 in.-lbs. (1.7±0.2 Nm).

NOTICE: If you are replacing a shower of sparks magneto, install the wire labeled “Advance” on the P-Lead terminal of the EIS. Do not use the wire labeled “Retard” – insulate this wire and tie it back.

XI. Spark Plugs & Harness

1. Re-install the spark plug with a new spark plug gasket into #1 cylinder. Torque to manufacturer’s specifications.
2. Connect ignition harness to spark plugs ensuring all wires are routed to the correct cylinders. Torque to manufacturer’s specifications.

XII. Placards

Fabricate and affix the placard below to the aircraft’s instrument panel in view of the pilot:

This aircraft is equipped with an electronic ignition system that requires continuous electrical power.
Do not operate aircraft with low battery voltage or an inoperative charging system.

XIII. Documentation

1. Since the EIS has been incorporated into the Lycoming engine specifications, installation of Lycoming EIS is considered a minor alteration to the engine. The engine installation portion can be completed with only an engine logbook entry.
2. The alterations required to the airframe to install the Lycoming EIS must be recorded in the airframe logbook per guidance provided on Page 1 of this Service Instruction.

XIV. Final Inspection

1. Visually inspect the following items:
 - EIS mounting hardware present and torqued
 - Power wire is connected and secure at EIS power terminal
 - Ignition harness and spark plugs installed and torqued
 - All wires, hoses and harnesses are properly secured along their entire route
 - Ensure the manifold pressure port (Figure 10) is not obstructed and open to atmospheric pressure.

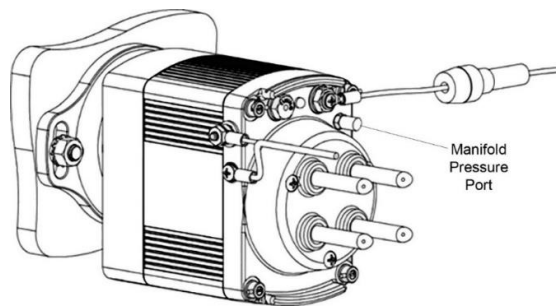

Figure 10: Typical 66K4A Installation and Terminal Attachment

- Confirm the placard is installed in accordance with Section XII in this chapter.
- Confirm the installation documentation and logbook entries are complete.

ISSUED			REVISED			PAGE NO.	REVISION	S.I. 1569
MO	DAY	YEAR	MO	DAY	YEAR			
04	08	20	04	21	21	10 of 18	B	

OPERATION

I. Pre-Operational Check

1. Ensure the ignition switch is turned off (p-lead grounded).
2. Clear the propeller area.
3. Turn the ignition switch on (p-lead un-grounded) and verify EIS LED illuminates and blinks.

NOTICE: The EIS timing pre-set code is set at the factory and cannot be reset in the field.

4. The EIS LED will blink the code which corresponds with the EIS timing pre-set. The code will repeat for 4 cycles before the LED goes inactive. Cycle the ignition switch to see the LED code again. Refer to Table 1 in Section IV of the INSTALLATION chapter for the correct code for your EIS.
5. If the LED blinks rapidly at 12 blinks/second, indicating an internal fault, the EIS is unairworthy and must be replaced.

II. Operational Check

1. Start the engine normally using Lycoming's recommended starting procedure.
2. If the engine does not run smoothly on the EIS, refer to Table 2 of this document for troubleshooting.
3. If corrective action cannot be taken or if a problem cannot be identified, stop and contact Lycoming.

MAINTENANCE

ICA EIS Ignition System

Introduction – 14 CFR §33 Appendix A33.3(a)(1):

The Electronic Ignition System (EIS) is a magneto replacement for Lycoming aircraft piston engines.

The EIS is available in 3 models:

- 66K4F – replaces impulse coupled magnetos on Lycoming 4-cylinder engines,
- 66K4A – replaces non-impulse coupled magnetos on Lycoming 4-cylinder engines,
- 66K6D – replaces magnetos on Lycoming 6-cylinder engines.
- All EIS models share the same design architecture but vary slightly to accommodate their intended installation.
- The EIS is designed to use existing aviation spark plugs gapped to OEM specifications.
- The EIS is designed to use a “Slick” style ignition harness.
- The EIS is designed to use existing magneto-to-engine drive gears and interfaces.

ISSUED			REVISED			PAGE NO.	REVISION	S.I. 1569
MO	DAY	YEAR	MO	DAY	YEAR			
04	08	20	04	21	21	11 of 18	B	

Detailed Description – 14 CFR §33 Appendix A33.3(a)(2):

The EIS operates in a Fixed timing mode – engine data-plate timing maintained throughout operational range.

NOTE

UNLIKE A MAGNETO, THE LYCOMING EIS IS TIMED (SYNCED) TO #1 CYLINDER COMPRESSION STROKE TDC (0°).

The EIS requires a constant, external supply of 8.5 – 30VDC power to operate.

Installation Instructions – 14 CFR §33 Appendix A33.3(a)(3):

Installation Instructions for 66K4F, 66K4A, and 66K6D models are found in the INSTALLATION chapter of this service instruction.

Basic Control & Operating Information – 14 CFR §33 Appendix A33.3(a)(4):

The EIS operates and is controlled like the magneto it replaces.

Servicing Information – 14 CFR §33 Appendix A33.3(a)(5):

The EIS does not require any servicing or lubrication

⚠ WARNING DO NOT COMPLETE A HIGH VOLTAGE (HIGH TENSION) LEAD TEST TO AN IGNITION HARNESS ATTACHED TO AN EIS.

Scheduling Information – 14 CFR §33 Appendix A33.3(a)(6):

The EIS does not require any cleaning, adjusting or testing. Inspection intervals and procedures:

1. Annually:
 - a. Inspect all wires connected to the EIS for correct routing, security, clamping, deterioration, damage, wear, fraying, chafing or breaks. Replace any deteriorated, damaged worn, frayed, chafed, or broken wires.
 - b. Inspect EIS for oil leaks. Identify and correct the cause.
 - c. Inspect ignition harness connection to EIS for general condition and security.
 - d. If Back-Up Battery System is installed, ensure it is being maintained or inspected in accordance with its ICA.
2. Upon propeller strike, engine overhaul or 2,400 hours of EIS operation:
 - a. Replace EIS with new unit.
3. Upon lightning strike, fire damage or water damage:
 - a. Replace EIS with new unit.
4. On condition:
 - a. Verify EIS LED blinks out correct code (refer to Section XVII),
 - b. Verify EIS is timed correctly to engine #1-cylinder TDC (refer the INSTALLATION chapter of this service instruction),
 - c. Troubleshoot using Table 2 in this service instruction or other appropriate engine troubleshooting practices if engine fails the magneto drop-off check in accordance with the engine operator's manual.

ISSUED			REVISED			PAGE NO.	REVISION	S.I. 1569
MO	DAY	YEAR	MO	DAY	YEAR			
04	08	20	04	21	21	12 of 18	B	

Testing:

The Lycoming EIS has been tested in accordance with test specification established in DO-160. DO-160 is a standard for environmental testing of avionics published by RTCA, the American Radio Technical Commission for Aeronautics. The following tables list the types and conditions of DO-160 testing performed during the development and certification of the Lycoming EIS.

DO-160G Section	Item	Category/Test Level
4	Temperature and Altitude	B3
5	Temperature Variation	A
6	Humidity	C External Humidity Environment
7	Operational Shocks and Crash Safety	B
8	Vibration	R with Vibration Curve 1
9	Explosive Atmosphere	E
10	Waterproofness	R
11	Fluids Susceptibility	F
12	Sand and Dust	S
13	Fungus Resistance	F (analysis)
14	Salt Fog	T
16	Power Input	B
17	Voltage Spike	A
18	Audio Frequency Conducted Susceptibility	B
19	Induced Signal Susceptibility	ZC
20	Radio Frequency Susceptibility <ul style="list-style-type: none"> • Conducted Susceptibility • Radiated CW & SW Susceptibility • Radiated Pulse Modulation Susceptibility 	W Y F
21	Emission of Radio Frequency Energy	B
22	Lightning Induced Transient Susceptibility	A3H3L3
25	Electrostatic Discharge (ESD)	A

RTCA/DO-160G Section	Environmental Test	Test Value
4.5.1	Ground Survival Low Temperature	-45°C
4.5.1	Short-term Operating Low Temperature	-38°C
4.5.2	Operating Low Temperature	-38°C
5.3.1c/1d	Temperature Variation	-45°C to 118°C
4.5.3	Ground Survival High Temperature	54°C
4.5.3	Short-term Operating Temperature	125°C
4.5.4	Operating High Temperature	118°C
5.3.1e/1h	Temperature Variation	-45°C to 118°C

ISSUED			REVISED			PAGE NO.	REVISION	S.I. 1569
MO	DAY	YEAR	MO	DAY	YEAR			
04	08	20	04	21	21	13 of 18	B	

Troubleshooting – 14 CFR §33 Appendix A33.3(a)(7):

Refer to Table 2 for troubleshooting guidelines of applicable EIS.

⚠ WARNING DO NOT COMPLETE A HIGH VOLTAGE (HIGH TENSION) LEAD TEST TO AN IGNITION HARNESS ATTACHED TO AN EIS.

**Table 2
EIS Troubleshooting Guide**

Problem	Problem Isolation			Probable Cause	Corrective Action
Unable to time EIS to engine	Engine is at #1 cylinder TDC	LED timing light on (solid) but unable to find the point when the LED goes off at TDC	4 cylinder engine	Drive gear installed upside down on EIS	Remove drive gear from EIS, rotate 180° axially and reinstall on EIS, reinstall EIS
			6 cylinder engine	Incorrect drive gear assembly tooth meshed with idler gear tooth	Remove EIS from engine, remove drive gear assembly from engine and reinstall in a different orientation, reinstall EIS
			All engines	Turning EIS shaft too rapidly	Turn EIS shaft slower. The LED goes off within a ½° window.
	LED timing light continuously off	EIS grounded to engine	No power at timing terminal	Verify power (8.5 to 30VDC) connected to timing terminal	
			Engine not grounded to airframe	Verify engine is grounded to airframe	
		EIS not grounded to engine	Insufficient case contact for ground	Ground EIS case to unpainted surface of engine	
	Engine is not at #1 cylinder TDC			#1 cylinder not @ TDC	Verify location of engine #1 cylinder. Turn engine to #1 cylinder TDC, reinstall EIS

ISSUED			REVISED			PAGE NO.	REVISION	S.I. 1569
MO	DAY	YEAR	MO	DAY	YEAR	14 of 18	B	
04	08	20	04	21	21			

**Table 2 (Cont.)
EIS Troubleshooting Guide**

Problem	Problem Isolation			Probable Cause	Corrective Action
Engine will not start, kicks back during start or does not run on EIS	Measured voltage at power terminal is within specification (8.5 to 30VDC)	P-lead terminal grounded	Terminal is grounded with P-lead wire installed	P-lead wire is connected to ground	Check ignition switch
			Check integrity of p-lead wire for chaffing to ground		
			Terminal is grounded with P-lead wire removed	Internal EIS fault	Contact Lycoming customer support
		P-lead terminal not grounded (open)	EIS is correctly timed to engine #1 cylinder TDC	Ignition harness wires connected to incorrect spark plugs	Check routing of harness wires
				Internal EIS fault	Contact Lycoming customer support
			Unable to verify EIS is correctly timed to engine #1 cylinder TDC	EIS not timed to engine correctly	Refer to Problem: Unable to time EIS to engine
	LED blinks rapidly (12 times per second)	Internal EIS fault	Contact Lycoming customer support		
	Unable measure power (8.5 to 30VDC) at power terminal	No or incorrect voltage to EIS	Verify EIS power wire is connected to power source and power source is within voltage range		
			Check EIS power wire integrity, terminals & fuse		

ISSUED			REVISED			PAGE NO.	REVISION	S.I. 1569
MO	DAY	YEAR	MO	DAY	YEAR			
04	08	20	04	21	21	15 of 18	B	

**Table 2 (Cont.)
EIS Troubleshooting Guide**

Problem	Problem Isolation			Probable Cause	Corrective Action	
Engine runs rough	Roughness is caused by EIS	EIS is correctly timed to engine #1 cylinder TDC	All spark plugs are firing (verified using CHT/EGT)	EIS LED Code (ref. Table 1) is configured correctly to engine base timing	Ignition harness wires connected to incorrect spark plugs	Correct routing of harness wires
					Internal EIS fault	Contact Lycoming customer support
				EIS LED Code is not configured correctly to engine base timing	EIS is not configured correctly to engine base timing	Contact Lycoming customer support
			Various spark plugs are not firing	Single spark plug not firing	Bad spark plug or ignition harness	Replace spark plug or ignition harness
		Pair of spark plugs not firing (1&2, 3&4, 5&6)		Internal EIS fault	Contact Lycoming customer support	
		Unable to verify EIS correctly timed to engine #1 cylinder TDC			EIS not timed to engine correctly	Refer to Problem: Unable to time EIS to engine
		LED blinks rapidly (12 times per second)			Internal EIS fault	Contact Lycoming customer support
		Roughness caused by magneto or ignition other than EIS			Non-EIS issue	Contact Lycoming customer support

ISSUED			REVISED			PAGE NO.	REVISION	S.I. 1569
MO	DAY	YEAR	MO	DAY	YEAR	16 of 18	B	
04	08	20	04	21	21			

**Table 2 (Cont.)
EIS Troubleshooting Guide**

Problem	Problem Isolation			Probable Cause	Corrective Action
Engine runs with higher than normal cylinder head temps.	EIS is correctly timed to engine #1 cylinder TDC	EIS LED Code (ref. Table 1) is configured correctly to engine base timing	Engine baffling is not deficient	Internal EIS fault	Contact Lycoming customer support
			Engine baffling is deficient	Insufficient engine cooling	Correct baffling deficiencies in accordance with OEM specifications
		EIS LED Code is not configured correctly to engine base timing		EIS is not configured correctly to engine base timing	Contact Lycoming customer support
		LED blinks rapidly (12 times per second)		Internal EIS fault	Contact Lycoming customer support
	EIS is incorrectly timed to engine #1 cylinder TDC			EIS incorrectly timed to engine	Reinstall EIS in accordance with installation instructions
	Unable to verify if EIS is correctly timed to engine #1 cylinder TDC				Refer to Problem: Unable to time EIS to engine

ISSUED			REVISED			PAGE NO.	REVISION	S.I. 1569
MO	DAY	YEAR	MO	DAY	YEAR			
04	08	20	04	21	21	17 of 18	B	

Removal– 14 CFR §33 Appendix A33.3(a)(8):

Remove the EIS in reverse order of the Installation Instructions listed in the INSTALLATION chapter of this service instruction.

List of Tools – 14 CFR §33 Appendix A33.3(a)(9):

The following tools may be required for maintenance:

1. Standard wrenches,
2. Standard screwdrivers,
3. Inspection mirror.

Overhaul & Repair – 14 CFR §33 Appendix A33.3(b)(1):

The requirement of 14 CFR §33 Appendix A33.3(b)(1) do not apply. The EIS’s are factory sealed and not designed to be overhauled or repaired. There are no re-useable components within each EIS.

Inspection Intervals and Mandatory Replacement Times – 14 CFR §33 Appendix A33.4(a)(1):

Refer to “Scheduling Information” in MAINTENANCE chapter of this Service Instruction.

FAA Approval – 14 CFR §33 Appendix A33.4(a)(2):

The Airworthiness Limitations section is FAA approved and specifies maintenance required under §§43.16 and 91.403 of Title 14 of the Code of Federal Regulations unless an alternative program has been FAA approved.

None

ISSUED			REVISED			PAGE NO.	REVISION	S.I. 1569
MO	DAY	YEAR	MO	DAY	YEAR			
04	08	20	04	21	21	18 of 18	B	