



Engine Maintenance Manual (Principal Manual)

IO-390-C Series

January 2017

Part No. MM-IO-390-C Series

IO-390-C Series

Engine Maintenance Manual

Lycoming Part Number: MM-IO-390-C Series

Contact Us:

Mailing Address:

Lycoming Engines
652 Oliver Street
Williamsport, PA 17701 USA

Phone:

Factory

U.S. and Canada Toll Free:

+1 (800) 258-3279

Direct:

+1 (570) 323-6181

Technical Support Hotline

- +1 (877) 839-7878 (Toll Free)
- +1 (570) 327-7222

Lycoming's regular business hours are Monday through Friday from 8:00AM through 5:00PM Eastern Time (-5 GMT).

Visit us Online: www.Lycoming.com

RECORD OF REVISIONS

Revision	Revision Date	Revised By	Revision Description
Original			Original Release of Maintenance Manual - Part No. MM-IO-390-C Series -

This page intentionally left blank.

SERVICE DOCUMENT LIST

NOTICE: The following is a list of service documents referenced in or incorporated into the information in this manual. Always refer to the latest revision of any service document (including any supplements) for changes or additional information.

Number	Incorporation Date	Subject
S.B. 201	01/17	Inspection of Crankshaft Flange
S.B. 225	01/17	Replacement of Valve Rocker Thrust Washers
S.B. 240	01/17	Mandatory Parts Replacement at Overhaul and During Repair or Maintenance
S.B. 342	01/17	Fuel Line (Stainless Steel Tube Assy.) and Support Clamp Inspection and Installation
S.B. 357	01/17	Engine Inspection After an Engine Has Been Soaked or Immersed
S.B. 369	01/17	Engine Inspection after Overspeed
S. B. 388	01/17	Procedure to Determine Exhaust Valve and Guide Condition
S.B. 398	01/17	Recommended Corrective Action for Use of Incorrect Fuel
S.B. 399	01/17	Action to Take If Loss of Oil Pressure
S.B. 401	01/17	Recommendations for Aircraft Struck by Lightning
S.B. 475	01/17	Crankshaft Gear and Crankshaft Gear End Inspection and Corrective Action
S.B. 480	01/17	Oil, Oil Filter, Oil Pressure Screen, and Oil Suction Screen Servicing
S.B. 505	01/17	Inspection of Crankshaft I.D. for Corrosion
S.B. 533	01/17	Recommended Action for Sudden Engine Stoppage, Propeller/Rotor Strike or Loss of Propeller/Rotor Blade or Tip
S.I. 1009	01/17	Recommended Time Between Overhaul Periods
S.I. 1011	01/17	Tappets and Lifters
S.I. 1012, Supplement 1, Supplement 2	01/17	Counterweights and Rollers on Engine Models
S.I. 1014	01/17	Lubricating Oil Recommendations
S.I. 1029	01/17	Tightening Procedures for Crankcase Thru-Studs and Bolts
S.I. 1037	01/17	Approved Pistons, Rings and Cylinders for Use on Lycoming Aircraft Engines

SERVICE DOCUMENT LIST (CONT.)

Number	Incorporation Date	Subject
S.I. 1042	01/17	Approved Spark Plugs
S.I. 1043	01/17	Spark Plug Heli-Coil® Insert Replacement
S.I. 1047	01/17	Inspection and Reconditioning Procedures for Nitride Hardened Steel Cylinders
S.I. 1059	01/17	Pre-Lubrication of Parts Before Assembly
S.I. 1060	01/17	Push Rod Identification
S.I. 1070	01/17	Specified Fuels for Spark Ignited Gasoline Aircraft Engine Models
S.I. 1080	01/17	Maintenance Items for Special Attention
S.I. 1098	01/17	Propeller Flange Bushing Location
S.I. 1129	01/17	Methods of Checking DC Alternator and Generator Belt Tension
S.I. 1141	01/17	Replacement of Worn Starter Ring Gears
S.I. 1143	01/17	Counterweight Bushing Inspection, Replacement, and Special Tooling Upgrades
S.I. 1154	01/17	FAA-Approved Starters and Alternators
S.I. 1172	01/17	Adjustable Oil Pressure Relief Valve Installation and Valve Seat Repair or Replacement
S.I. 1191	01/17	Cylinder Compression Check
S.I. 1241	01/17	Pre-oil the Engine Prior to Initial Start
S.I. 1267	01/17	Piston Pin Plug Usage
S.I. 1285	01/17	Non-Destructive Testing of Lycoming Engine Parts
S.I. 1290	01/17	Repair of Oil Leakage at Crankcase Thru-Stud Locations; Assembled and Unassembled Engines.
S.I. 1301	01/17	Identification of Primer and Fuel Injector Lines
S.I. 1304	01/17	Engine Nameplate Replacement
S.I. 1316	01/17	Valve Seat Refacing on Oil Cooler Bypass Valves
S.I. 1324	01/17	Crankshaft Oil Seals
S.I. 1340	01/17	Piston Pin Identification
S.I. 1343	01/17	Set Screw for Propeller Governor Idler Shaft
S.I. 1409	01/17	Lycoming Engines P/N LW-16702 Oil Additives
S.I. 1425	01/17	Suggested Maintenance Procedures to Reduce the Possibility of Valve Sticking
S.I. 1427	01/17	Field Run-In and Break-In
S.I. 1458	01/17	Connecting Rod Bolts (Identification and Installation)

SERVICE DOCUMENT LIST (CONT.)

S.I. 1462	01/17	Propeller Oil Control Leak Test Procedure
S.I. 1485	01/17	Exhaust Valve and Guide Identification Procedure
S.I. 1492	01/17	Piston Pin Plug Wear Inspection
S.I. 1514	01/17	Roller Tappets Part Information Update
S.I. 1529	01/17	Hydraulic Lifter and Tappet Body Part Numbers
S.I. 1530	01/17	Engine Inspection in Particulate-Laden Environments
S.I. 1535	01/17	Counterweight and Roller Removal, Inspection, and Installation
S.I. 1566	01/17	Lycoming Engines Approves the Use of Safety Cable
S.L. L114	01/17	Reciprocating Engine and Accessory Maintenance Publications
S.L. L171	01/17	General Aspects of Spectrometric Oil Analysis
S.L. L180	01/17	Engine Preservation Guidelines for Active and Stored Aircraft
S.L. L192	01/17	Spark Plug Fouling
S.L. L197	01/17	Recommendations to Avoid Valve Sticking
S.L. L221	01/17	Warranty Repair of Precision Airmotive Corporation Fuel Control Products
S.L. L247	01/17	Shelf Life Requirements
S.L. L253	01/17	Warranty Repair of AVStar Fuel Systems, Inc. Fuel Control Products

This page intentionally left blank.

TABLE OF CONTENTS

<u>Subject</u>	<u>Page</u>
Title Page	i
Record of Revisions	i
Service Document List	iii
Table of Contents	vii
Abbreviations and Acronyms	xvii
Introduction	xix
Airworthiness Limitations	xxiii
Required Maintenance	05-00
— Required Maintenance	1
— General	1
—Table 1 - Tools for Service and Maintenance	1
— Time Between Overhaul (TBO).....	2
— Safety Precautions - Before Engine Maintenance.....	3
— Maintenance Practices.....	3
— General Engine Inspection Criteria.....	4
— Requirements for Engine Maintenance.....	4
— Approved Parts.....	5
Time Limits / Service Checks	05-10
— Engine Inspection Schedule for IO-390-C Series Engines	7
Required Engine Inspections for IO-390-C Series Engines	05-20
— Engine Inspections	9
— Visual Inspection for IO-390-C Series Engines.....	9
— Operational Leak Check Sheet for IO-390-C Series Engines.....	15
— 10-Hour Initial Engine Inspection for IO-390-C Series Engines.....	16
— 25-Hour Engine Inspection for IO-390-C Series Engines	17
— 50-Hour Engine Inspection for IO-390-C Series Engines	20
— 100-Hour or Annual Engine Inspection for IO-390-C Series Engines	23
— 400-Hour Engine Inspection for IO-390-C Series Engines	28
— 500-Hour Engine Inspection for IO-390-C Series Engines	30
— 1000-Hour Engine Inspection for IO-390-C Series Engines	31

<u>Subject</u>	<u>Page</u>
Cleaning	05-30
— Cleaning Guidelines	33
—Table 1 - Cleaning Guidelines for Engine Components	34
— Crankshaft Cleaning.....	36
— Crankshaft Counterbore Cleaning.....	36
— Crankshaft Gear Cleaning.....	37
— Tappet Cleaning	37
— Crankcase Cleaning.....	38
— Grit-Blasting.....	38
— Soft Carbon Removal.....	39
— Hard Carbon Removal	39
— Cylinder Cleaning	40
— Piston Cleaning	40
— Injection Nozzle Cleaning.....	41
— Steel, Aluminum, or Magnesium Parts Cleaning.....	42
— Spark Plug Cleaning.....	42
— Lead Deposit Removal.....	42
— Volcanic Ash Removal	43
— Cleaning Guidelines for a Soaked Engine	43
— Cleaning Method for Non-Destructive Testing	44
Unscheduled Corrective Maintenance	05-50
— Lightning Strike - After a Lightning Strike	45
— Engine Overspeed	45
—Table 1 - Overspeed Values for IO-390-C Series Engines	46
— Incorrect Fuel or Fuel Contamination.....	48
— Soaked Engine.....	49
— Engine on Fire or Near a Fire.....	51
— Hydraulic Lock	51
— Volcanic Ash/Particulate Contamination.....	52
—Table 2 - Action to Take in Volcanic Ash Conditions.....	52
— Valve Sticking.....	53
— Oil Starvation/Sudden Loss of Oil Pressure	54

Subject	Page
Unscheduled Corrective Maintenance (Cont.)	05-50
— Propeller Strike, Sudden Engine Stoppage or Loss of a Propeller Blade Tip.....	55
— Engine Inspection Checklist After Propeller Strike for IO-390-C Series Engines	56
— Non-Destructive Testing (Magnetic Particle Inspection and Fluorescent Penetrant Inspection.).....	62
Servicing - Replenishing	12-10
— Refueling.....	63
— Oil Level Check	63
— Oil Consumption	64
— Oil Type and Viscosity	64
— Add Oil to the Engine	64
— Oil Leak Check	65
— Oil Servicing Schedule.....	65
— Oil Change Procedure	66
— Engine Pre-Oil Procedure	67
— Oil Suction Screen Removal/Inspection/Cleaning/Installation.....	68
— Oil Pressure Screen Removal/Inspection/Cleaning/Installation	69
— Oil Filter Replacement.....	70
— Oil Filter Inspection	71
— Engine Wear and Oil Analysis.....	71
Fault Isolation	12-30
— Recommended Approach to Fault Isolation.....	73
— Fault Isolation Guide.....	73
— Table 1 - Fault Isolation Guide	73
Engine Removal and Return to Service	72-00
— Engine Removal Prerequisites	87
— Engine Removal Procedure.....	87
— Engine Installation Preparation Requirements.....	89
— Table 1 - Materials and Procedures to Prepare a Serviced Engine for Installation	89
— Operational Ground Check	90
— Idle Speed and Mixture Adjustment	90
— Engine Mount Inspection.....	91
— Return to Service Procedure	92

Subject	Page
Engine Disassembly.....	72-05
— Table 1 - Sequence of IO-390-C Engine Series Disassembly Procedures.....	93
Engine Assembly	72-10
— Table 1 - Sequence of IO-390-C Engine Series Assembly Procedures	99
— General Assembly Practices.....	105
— Corrosion Prevention	105
— Painting the Engine and Engine Components.....	105
— Limits and Clearances.....	108
— Inspections	108
— Engine Assembly Checklist.....	109
Propeller Flange Bushing Replacement.....	72-15
— Propeller Flange Bushing Removal	115
— Propeller Flange Bushing Installation.....	115
Crankcase Maintenance	72-20
— Crankcase Inspection Before Disassembly	117
— Connecting Rod Removal	117
— Crankcase Disassembly.....	118
— Tappet, Main Bearing, and O-Ring Removal	119
— Propeller Governor Drive Removal / Disassembly (Engines with Front-Mounted Propeller Governor Drives)	121
— Oil Plug Removal.....	122
— Crankshaft Idler Gear Shaft Removal.....	122
— Piston Cooling Nozzle Removal.....	123
— Crankshaft Disassembly.....	123
— Counterweight Removal	125
— Crankcase Dimensional Inspection.....	126
— Crankshaft Inspection	128
— Alignment Dowel Inspection	137
— Crankshaft Bearing Surface Inspection.....	138
— Camshaft Inspection.....	139
— Connecting Rod Inspection.....	140
— Connecting Rod Parallelism / Squareness Check	143

Subject	Page
Crankcase Maintenance (Cont.)	72-20
— Tappet Inspection.....	144
— Crankshaft Assembly.....	144
— Alignment Dowel Replacement.....	144
— Crankshaft Gear Installation.....	145
— Expansion Plug Installation.....	147
— Solid-Ring Crankshaft Oil Seal Installation.....	148
— Connecting Rod Installation.....	150
— Counterweight Installation.....	151
— Piston Cooling Nozzle Installation (if removed).....	153
— Crankshaft Idler Gear Shaft Installation.....	153
— Oil Plug Installation (if removed).....	154
— Tappet Assembly Installation.....	154
— Crankshaft Bearing and O-Ring Installation.....	155
— Propeller Governor Drive Installation (Engines with Front-Mounted Propeller Governor Drives).....	156
— Camshaft Assembly and Installation.....	158
— Crankshaft Installation.....	160
— Crankcase Assembly.....	161
— Crankshaft Oil Seal Installation.....	166
— Crankshaft Idler Gear Installation.....	168
— Crankshaft Endplay Clearance Check.....	168
— Propeller Oil Control Leak Test.....	169
— Propeller Governor Removal (Engines with Front-Mounted Propeller Governor Drives).....	171
— Propeller Governor Installation (Engines with Front-Mounted Propeller Governor Drives).....	171
— Crankshaft-to-Camshaft Timing Check.....	171
Accessory Housing Maintenance	72-25
— Accessory Housing Removal.....	173
— Oil Pump Removal.....	174
— Oil Pump Installation.....	174

Subject	Page
Accessory Housing Maintenance (Cont.)	72-25
— Fuel Pump Plunger Removal	175
— Fuel Pump Plunger Inspection	175
— Fuel Pump Plunger Installation	175
— Accessory Housing Installation	175
— Propeller Governor Replacement (Engines with Rear-Mounted Propeller Governor Drives)	177
Cylinder Maintenance	72-30
— General	179
— Visual Cylinder Inspection	179
— Cylinder Compression Check	180
— Table 2 - Summary of Cylinder Compression Check Results and Corrective Action	184
— Intercylinder Baffle Inspection	185
— Cylinder Borescope Inspection	186
— Table 3 - Borescope Inspection Steps, Results and Corrective Action	187
— Exhaust Valve and Guide Inspection	187
— Cylinder Removal	192
— Piston Removal	196
— Cylinder Assembly Inspection	197
— Piston Inspection	201
— Piston Ring Replacement	205
— Piston Installation	206
— Intake Valve Replacement	207
— Exhaust Valve Replacement	208
— Cylinder Installation	209
— Corrective Action for Valve Sticking	215
— Intake and Exhaust Valve Guide Replacement	216
— Intake and Exhaust Valve Seat	216
— Barrel Glaze and Varnish Removal from Interior Cylinder Barrel	217
— Heli-Coil® Replacement	217

Subject	Page
Lubrication System Maintenance.....	72-50
— Oil Pressure Adjustment	219
— Oil System Inspection	219
— Oil Line Inspection.....	219
— Oil Line Replacement	220
— Oil Level Gage Tube and Assembly Removal.....	220
— Oil Level Gage Tube and Assembly Installation	220
— Oil Pressure Relief Valve Removal	221
— Oil Pressure Relief Valve Inspection	221
— Oil Pressure Relief Valve Installation.....	221
— Thermostatic Oil Cooler Bypass Valve Removal	222
— Thermostatic Oil Cooler Bypass Valve Cleaning	222
— Thermostatic Oil Cooler Bypass Valve Installation	222
— Oil Pressure Screen Housing Removal	223
— Oil Pressure Screen Housing Installation.....	223
— Oil Filter Base Removal.....	223
— Oil Filter Base Installation	223
— Oil Sump Removal.....	224
— Oil Sump Installation	225
— Propeller Governor Oil Line Removal (Engines with Rear-Mounted Propeller Governor Drives)	227
— Propeller Governor Oil Line Installation (Engines with Rear-Mounted Propeller Governor Drives)	227
Accessory Drives	72-60
— Accessory Drive Inspection	229
— Vacuum Pump Replacement.....	229
— Vacuum Pump Driven Gear Replacement.....	229
— Propeller Governor Drive Replacement (Engines with Rear-Mounted Propeller Governor Drives)	230
Electrical System Maintenance.....	72-70
— Wiring Inspection.....	233
— Alternator Belt Inspection.....	233
— Alternator Belt Tension Check/Adjustment.....	233

Subject	Page
Electrical System Maintenance (Cont.).....	72-70
— Alternator and Bracket Removal.....	236
— Alternator and Bracket Installation.....	236
— Alternator Belt Replacement.....	237
— Starter Replacement.....	237
— Starter Ring Gear Support Replacement.....	238
— Starter Ring Gear Replacement.....	239
Induction System Maintenance.....	72-80
— Induction System Inspection.....	241
— Intake Pipe Replacement.....	241
— Fuel Drain Valve Adapter Assembly Inspection.....	242
Engine Fuel and Control – Distribution Maintenance.....	73-10
— Fuel System Inspection.....	243
— Fuel Line Inspection.....	245
— Fuel Injector Leak Check.....	249
— Fuel System Inspection Checklist.....	249
— Fuel Line Replacement.....	251
— Fuel Injector Replacement.....	254
— Injection Nozzle Replacement.....	255
— Injection Nozzle Fuel Flow Check.....	257
— Fuel Manifold Replacement.....	257
— Fuel Pump Replacement.....	259
Ignition System Maintenance.....	74-20
— Spark Plugs.....	261
— Spark Plug Removal.....	261
— Ignition Harness Inspection.....	262
— Spark Plug Inspection.....	262
— Spark Plug Fouling.....	263
— Spark Plug Port Seal Inspection.....	264
— Spark Plug Cleaning.....	264
— Spark Plug Gap Setting.....	264

Subject	Page
Ignition System Maintenance (Cont.).....	74-20
— Spark Plug Rotation	264
— Spark Plug Installation	265
— Ignition Harness Removal.....	266
— Ignition Harness Inspection	266
— Ignition Harness Installation	267
Magneto Maintenance	74-30
— Magneto Inspection.....	269
— Magneto-to-Engine Timing Check	269
— Magneto Adjustment Procedure.....	271
— Magneto Replacement Procedure	271
Exhaust System Inspection.....	78-00
— Exhaust System Inspection	275
Appendix A	
— Crankcase Stud Replacement.....	277
— Fin Stabilizer Installation.....	278
— Install Stud at Oil Filter Pad (if Required).....	279
— Hydraulic Pump Adapter Assembly Installation (if Required).....	280
— Hydraulic Pump Replacement (if Required).....	280

This page intentionally left blank.

ABBREVIATIONS AND ACRONYMS

A	
AMM	Airframe Manufacturer's Manual
ATA	Air Transport Association
C	
C	Celsius
cm	Centimeter
E	
EGT	Exhaust Gas Temperature
F	
F	Fahrenheit
FAA	Federal Aviation Administration
FAR	Federal Aviation (and Space) Regulation
ft.-lb	Foot Pound (torque)
FOD	Foreign Object Debris
FPI	Fluorescent Penetrant Inspection
G	
Gal.	Gallon
I	
ICAs	Instructions for Continued Airworthiness
ID	Inner / Inside Diameter
in.-lb.	Inch Pound (torque)
in.	Inch, inches
IOM	Engine Installation and Operation Manual
K	
Kg	Kilogram
kPa	Kilopascal
L	
l	Liter
lb.	Pound
M	
MEK	Methyl-Ethyl-Ketone
mm	Millimeter
MPI	Magnetic Particle Inspection
N	
NDT	Non-Destructive Testing
Nm	Newton Meter

ABBREVIATIONS AND ACRONYMS (CONT.)

O	
OD	Outer / Outside Diameter
OEM	Original Equipment Manufacturer
oz	Ounce
P	
PMA	Parts Manufacturer Approval
P/N	Part Number
POH	Pilot's Operating Handbook
psi	Pounds per square inch
R	
rpm	Revolutions per Minute
S	
SAE	Society of Automotive Engineers
SB	Service Bulletin
SI	Service Instruction
STC	Supplemental Type Certificate
T	
TBO	Time Between Overhaul
TDC	Top Dead Center
TIR	Total Indicator Reading

INTRODUCTION

The Lycoming IO-390-C series engines are direct-drive four-cylinder, horizontally opposed, fuel-injected, air-cooled engines. Each engine has tuned induction and a down exhaust.

There are different IO-390-C engine models. Figures 1 and 2 show the IO-390-C engine models. The main difference between the engine models has to do with the location of the propeller governor. The IO-390-C1A6 and -C3A6 models have an optional propeller governor installed on the rear of the engine. Whereas, on the IO-390-C1B6 and C3B6 engine models, the propeller governor is installed on the front of the crankcase.

There are different propeller flange bushing configurations for these engine models. Refer to the latest revision of Service Instruction No. SI-1098 for the configuration for your engine model.

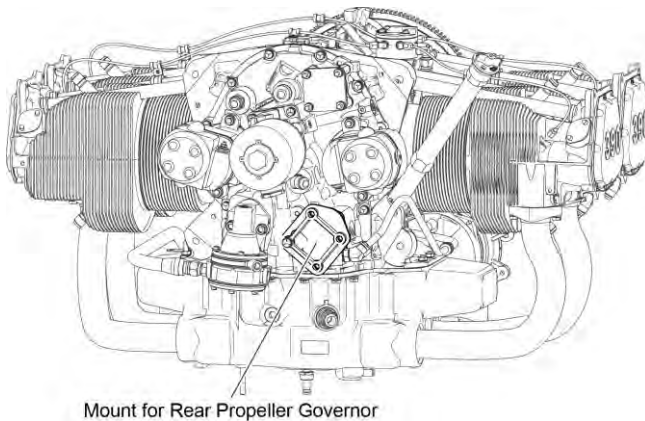


Figure 1
IO-390-C1A6, -C3A6 Engine

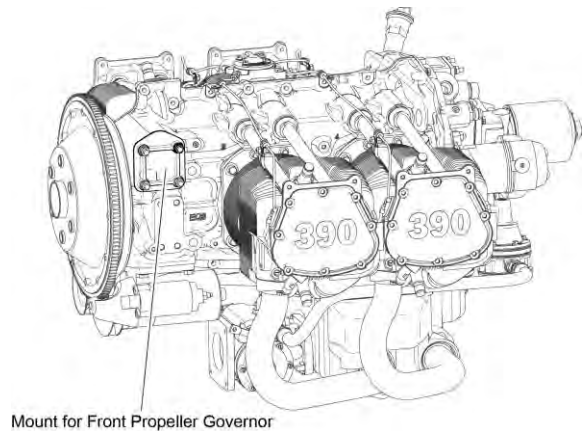


Figure 2
IO-390-C1B6, -C3B6 Engine

Engine Model Nomenclature

The table below identifies the basic nomenclature of the IO-390 engine models. Hyphenated numbers and letters in the suffix (C1A6, C3A6, C1B6, or C3B6) of the engine model number are configuration designations associated with the core engine.

Model Number	Meaning
I	Fuel Injected
O	Horizontally Opposed
390	Displacement in cubic inches

Engine Serial Number

Every engine sent from the factory is identified by a unique serial number. The engine serial number is identified on the engine data plate (Figure 3). Do not remove the engine data plate.

If an engine data plate is ever lost or damaged, refer to the latest revision of Service Instruction No. SI-1304 for engine data plate replacement information.



Figure 3
Engine Data Plate

Cylinder Number Designations

- The propeller is at the front of the engine.
- When viewed from the top of the engine, the left side cylinders are 2-4. Cylinder 2 is at the front of the engine. Refer to Figure 4.
- When viewed from the top of the engine, the cylinders on the right are 1-3. Cylinder 1 is at the front of the engine. Refer to Figure 4.
- The firing order of the cylinders is 1-3-2-4.

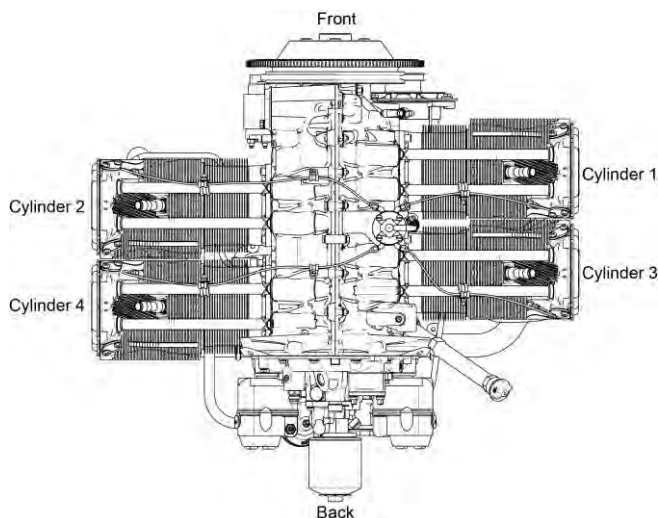


Figure 4
Top View of Engine – Cylinder Number Designations

Scope of this Manual

This manual supplies instructions (in compliance with Federal Aviation Regulation (FAR 33.4)) for maintenance of the Lycoming IO-390-C Series engine. These instructions include: required maintenance (service information) such as: oil changes, oil addition, oil filter replacement/oil pressure screen cleaning, routine time-interval inspections, routine service, spark plug replacement/inspection procedures, cylinder inspection, fuel system inspection, scheduled servicing procedures, airworthiness limitations, fault isolation guidelines and procedures to replace components and to disassemble and assemble the engine. Refer to the applicable parts catalog to identify spare parts.

Instructions for Continued Airworthiness

This manual, the latest revision of the *Service Table of Limits - SSP-1776*, and service documents make up the complete set of Instructions for Continued Airworthiness (ICAs). The ICAs are prepared by Lycoming Engines and are accepted by the Federal Aviation Administration (FAA).

Engine Certification

This manual adheres to guidelines set forth by the FAA for certified engines. All inspections, procedures, and guidelines in this manual must be followed to maintain continued airworthiness.

Compliance Requirements


⚠ WARNING: FOR CORRECT ENGINE MAINTENANCE, COMPLETE THE NECESSARY MAINTENANCE PROCEDURES IN THIS MANUAL AND APPLICABLE SERVICE DOCUMENTS. LYCOMING ENGINES' SERVICE DOCUMENTS WRITTEN AT A LATER DATE SUPERSEDE PROCEDURES IN THIS MANUAL UNLESS OTHERWISE SPECIFIED.
PROCEDURES IN THIS MANUAL MUST BE DONE BY QUALIFIED PERSONNEL WITH THE REQUISITE CERTIFICATIONS.

Before you do maintenance on the IO-390-C series engine, read this manual in its entirety. Obey all procedures and inspections in this manual.

NOTICE: If you do not obey the maintenance procedures in this manual for this engine, you can void the engine warranty. Refer to your warranty for details.

Refer to the *IO-390-C Series Engine Installation and Operation Manual* for engine description, uncrating procedures, acceptance check, engine lift procedure, engine preservation and storage, depreservation, engine installation requirements, engine installation, operation and stop procedures, engine initiation (break-in/flight test), fuels and oil to be used, and operating specifications.



Refer to the latest revision of the *Service Table of Limits - SSP-1776*, for dimensions, clearances, measurements, and torque values.

 WARNING: OPERATE THIS ENGINE IN ACCORDANCE WITH SPECIFICATIONS IN APPENDIX A OF THE IO-390-C SERIES ENGINE INSTALLATION AND OPERATION MANUAL. OPERATING THE ENGINE BEYOND SPECIFIED OPERATING LIMITS CAN CAUSE PERSONAL INJURY AND/OR DAMAGE TO THE ENGINE.

Warnings, Cautions, and Notices

Be sure to read and obey the Warnings, Cautions, and Notices in this manual and in service documents. Although Lycoming Engines cannot know all possible hazards or damages, it makes a reasonable effort to supply the best known guidance and recommended practices for safe operation and maintenance of its engines.

The table below defines the four types of safety advisory messages used in this manual as per the American National Standard and ANSI Z535-6-2006.

Safety Advisory Conventions	
Advisory Word	Definition
<u>DANGER:</u>	Indicates a hazardous situation which, if not avoided, will result in death or serious injury. This signal word is to be limited to the most extreme situations.
 WARNING:	Indicates a hazardous situation which, if not avoided, could result in death or serious injury.
 CAUTION:	Indicates a hazardous situation which, if not avoided, could result in minor or moderate injury. It also can be used without the safety alert symbol as an alternative to " NOTICE. "
<u>NOTICE:</u>	The preferred signal word to address practices not related to personal injury.

NOTICE: In this manual, the word "recommend" refers to "best practices."

Service Bulletins, Service Instructions, and Service Letters

As advancements in technological applications on this engine continue, Lycoming will make future revisions to this manual. However, if more timely distribution is necessary, Lycoming supplies up-to-date Service Bulletins (SBs), Service Instructions (SIs) and Service Letters (which are abbreviated with a capital "L" followed by the number, example L180). Special Advisories (SAs) are supplied as necessary.

For additional publication information, look on Lycoming's website (Lycoming.com) or speak to Lycoming Engines by telephone: U.S. and Canada toll free: +1(800) 258-3279; or Direct: +1 (570) 323-6181.

Applicable information from Lycoming Engines' Service Bulletins, Service Instructions, and Service Letters are included in this manual at the time of publication. Any new service information will be included in the next update of the manual.

Reminder: Unless otherwise specified, Lycoming Engines' service documents (which have a later date than this manual) override procedures in this manual.

For reference, the Service Document List at the front of this manual shows the editions of the service documents referenced or included in this manual.

List of Publications

Refer to the latest revision of Service Letter No. L114 for a list of Lycoming Engines' publications.

Environmental Compliance

Lycoming Engines recommends that engine owners and engine service personnel be in compliance with all federal, state, and local environmental regulations when solvents, paint, fuel, oil, chemicals, or other consumables are used in engine service.

Simplified Technical English

The text in this manual is written in the form of Simplified Technical English in compliance with FAA requirements and to make translation into other languages easier.

Format

Chapters in this manual are identified in Air Transport Association (ATA) format.

Figures

Figures in this manual are for illustration purposes only. Figures always start as Figure 1 in each chapter.

Copyright

This publication is a copyrighted work. All rights reserved by Lycoming Engines. Content in this manual cannot be changed or released as a reprint, electronic media output, or web communiqué without written permission from Lycoming Engines.

Feedback

To supply comments, suggestions, or corrections to this manual, either make a call to customer service or use the Lycoming.com website.

AIRWORTHINESS LIMITATIONS

1. General

This Airworthiness Limitations chapter sets forth each mandatory replacement time, inspection interval, and related procedure required for type certification. The Airworthiness Limitations chapter is FAA approved and specifies maintenance required under §§ 43.16 and 91.403 of the Federal Aviation Regulations (FAR) unless an alternative program has been FAA-approved.

2. Mandatory Inspection - Fuel Injector Lines

At every 100 hours of operation and after any maintenance has been done on the engine where the fuel injector lines have been disconnected, moved or loosened, examine the fuel lines per the "Fuel Line Inspection" procedure in Chapter 73-10 of this manual.

3. Mandatory Inspection

At every 500 hours of operation, examine the magnetos in accordance with the applicable magneto manufacturer's instructions.

4. Mandatory Inspection - Exhaust Valve and Guide

At every 1000 hours of operation for IO-390-C Series engines, examine the exhaust valve and guide conditions. Refer to the section "Exhaust Valve and Guide Inspection" in Chapter 72-30 of this manual.

Approved by: Chris Marnetto FOR
Gaetano Sciortino
Manager, New York Aircraft Certification Office
Federal Aviation Administration
Date: 1/25/2017

This page intentionally left blank

05-00 - REQUIRED MAINTENANCE

1. Required Maintenance

Required maintenance on these engines oil changes includes: oil addition, oil filter replacement/oil pressure screen cleaning, routine time-interval inspections, routine service, spark plug replacement/inspection procedures, cylinder inspection, fuel system inspection and other procedures identified in the checklists in Chapters 05-20 of this manual.

2. General

In addition to instructions for required service and maintenance of the Lycoming IO-390-C Series engine, this manual also includes fault isolation guidelines and procedures for component replacement, engine disassembly, and engine assembly. Refer to the applicable parts catalog to identify spare parts.

- A. Engine description, uncrating procedures, acceptance check, engine lift procedure, engine preservation and storage, depreservation, engine installation requirements, engine installation, engine start, operation, and stop procedures, engine initiation (break-in/flight test), fuels and oil to be used, and operating specifications are included in the *IO-390-C Series Engine Installation and Operation Manual*.
- B. List of Tools for Service and Maintenance

Table 1 identifies tools used for service and maintenance.

Table 1
Tools for Service and Maintenance

Tool	Purpose
Champion Tool CT-470 or Airwolf Cutter AFC-470 or equivalent	Cut open oil filter
Borescope	Cylinder Borescope Inspection
Aviation Mechanic's Tools	
Differential Compression Tester	Cylinder Compression Check
Valve Clearance Gage	Dry tappet clearance
Baffle Retainer Hook	
Plug Gage	Measure inner diameter of the valve guide
Imada DPS-220R or equivalent	Spring Tester - Available from Tool Vendor
Dial Bore Gage	Measure cylinder diameter
Thickness Gage	Measure paint coating thickness
Arbor Press Spindle	Counterweight bushing removal

**Table 1 (Cont.)
Tools for Service and Maintenance**

Tool No.	Nomenclature and Description
ST-23	Gage, Valve Clearance 0.028 to 0.080 in.
ST-25	Compressor, Valve Spring
ST-92	Counterweight Bushing Driver
ST-93	Counterweight Fixture Assembly
ST-93-3	Depth Control Spacer
ST-93-5	Depth Control Spacer
ST-115	Tool, Install and Remove Propeller Flange Bushings
ST-131	Belt Tension Dial Gage
ST-142	Shroud Tube Wrench
ST-222	Plate, Torque Hold-Down
ST-271	Puller, Crankcase Thru-Stud
*ST-310	Gage, Check Bell-Mouthing of Exhaust Valve Guides
ST-317	Driver, Crankcase Thru-Stud
ST-383	Tool, Crankshaft Oil Seal Installation
ST-389	Tool, Crankcase Separating
ST-483	Test Plate
ST-485	Compressor, Piston Ring
64530	Connecting Rod Parallelism and Squareness Gage
64526-2	Block, Cylinder
64593	Expanding and Staking Tool, 0.71 in. (18 mm) Spark Plug Heli-Coil® Insert
64594	Inserting Tool, 18 MM Spark Plug Heli-Coil® Insert
64596-1	Tap, 18 mm Heli-Coil® Spark Plug Bottom Tap 0.010 in. (0.254 mm) OS
64892	Circlip Check Gage
64941	Tappet Assembly Tool
* Gage, Check Bell-Mouthing of Exhaust Valve Guides (ST-310) includes Gage Adapter ST-310-9	

3. Time Between Overhaul (TBO)

Refer to the latest revision of Service Instruction No. SI-1009 for any changes or special circumstances for the recommended TBO.

Lycoming Engines recommends engines be sent to the factory for overhaul.

4. Safety Precautions - Before Engine Maintenance

⚠ WARNING: BEFORE THE START OF ANY SERVICE OR MAINTENANCE ON AN INSTALLED ENGINE OR AN ENGINE ON A TEST STAND CONNECTED TO POWER, ENSURE THE IGNITION SWITCH IS TURNED OFF AND DISABLE/DISCONNECT ALL POWER TO THE ENGINE TO PREVENT ACCIDENTAL ENGINE START-UP. FAILURE TO DISABLE POWER COULD CAUSE ACCIDENTAL ENGINE START-UP, INJURY, OR DEATH. ENSURE ALL OBJECTS/PERSONNEL ARE CLEAR OF THE PROPELLER'S ROTATIONAL ARC. IF POWER IS ON, A LOOSE OR BROKEN WIRE CAN CAUSE THE ENGINE TO START AND THE PROPELLER TO TURN WHICH CAN LEAD TO DEATH OR SERIOUS INJURY OR A PROPELLER STRIKE. IF IT IS NECESSARY TO COMPLETE OPERATIONAL TESTS ON THE ENGINE WITH POWER ON, KEEP ALL PERSONNEL AWAY FROM THE ROTATIONAL RADIUS OF THE PROPELLER TO PREVENT INJURY OR DEATH ON ENGINE START-UP.

- A. Disconnect the battery.
- B. Remove access panel(s), cowling(s) and/or baffles for access to areas.

5. Maintenance Practices

- A. Obey all safety precautions.
- B. Do not reuse a gasket, O-ring, or seal. Install a new gasket, O-ring, or seal during component installation where a gasket, O-ring, or seal was removed.
- C. If maintenance is done that could cause contamination of the internal components of the engine, complete the "Oil Change Procedure" in Chapter 12-10.
- D. Remove all traces of dirt, dust, debris and accumulated matter from parts. All parts must be clean before they are installed on the engine. For specific cleaning guidelines, refer to Chapter 05-30.
- E. If adhesive tape has been applied to any part, remove the tape and all residue. Clean the part completely.
- F. Hardware
 - (1) All cotter pins that are removed must be discarded and not reused. Install a new cotter pin where a cotter pin was removed.
 - (2) All safety wire and cotter pins must be made of corrosion-resistant steel and installed as a snug fit in holes in studs and bolts for correct locking.
 - (3) If safety wire or safety cable was removed during component removal, be sure to install new safety wire or safety cable during component installation.
 - (4) All safety cable installed on the engine must meet or exceed specifications in the latest revision of AS3510. Safety cable must be installed per the safety cable manufacturer's instructions and in accordance with specifications in the latest revisions of AS4536 and AS567 and the latest revision of Service Instruction No. SI-1566.

- (5) The cotter pin head must install as a snug fit into the castellation of the nut. Unless otherwise specified, bend one end of the cotter pin back over the stud or bolt and the other end flat against the nut.
 - (6) Any damaged or unserviceable hardware, fasteners, studs, screws, bolts, nuts, washers, and clamps must be replaced with new parts.
 - (7) Unless otherwise directed, lock washers and lock nuts must be replaced with new lock washers and lock nuts.
 - (8) Although the latest revision of Service Bulletin No. SB-240 identifies parts which must be replaced after they are removed, in the case where other parts are removed, it is recommended practice, prior to installation, to examine each part for damage or wear and replace the part as needed in accordance with accepted practices and standards to ensure that serviceable parts are installed on the engine.
- A. Unless otherwise specified in this manual, refer to the latest revision of the ***Service Table of Limits - SSP-1776*** for standard torque values for fittings, plugs, and hardware fasteners as well as special torque requirements for fittings, valves, clamps, couplings, and other hardware fasteners in various locations on the engine.
 - B. Specific engine parts must be lubricated during engine assembly. Many premature part failures have been caused by incorrect pre-lubrication during engine assembly. If parts are not correctly lubricated, or if an unapproved lubricant is used, engine parts could become scored before the engine oil has lubricated the engine during the first cycle of operation. This scoring can cause premature part failure, or, in some cases, engine failure. As preventive action, during engine assembly and individual engine component replacement, apply the approved lubricant for specified components identified in the latest revision of Service Instruction No. SI-1059.
 - C. Complete the Operational Ground Check prior to and after each inspection, after maintenance, and after engine assembly. Refer to Chapter 72-00.
6. General Engine Inspection Criteria

During visual inspection, replace engine components including the crankcase, oil sump, and accessory housing with:

- Replace the component if there is any raised metal on surfaces
- Replace the component if there is any scratch, ding, dent, or pit, that exceeds 0.050 in. (1.27 mm) depth
- Make sure dowels fully seat in crankcase hole
- Replace any bent, damaged, or stripped studs, refer to Appendix A

7. Requirements for Engine Maintenance

- A. These engines must be maintained using Lycoming Engines' approved methods and procedures.
- B. Refer to the latest revision of Service Bulletin No. SB-240 for a list of parts must be replaced whenever they are removed.

8. Approved Parts

⚠ CAUTION: LYCOMING DOES NOT GIVE APPROVAL FOR USE OF PARTS MANUFACTURER APPROVAL (PMA) PARTS ON ITS ENGINES. LYCOMING INSTALLATION INSTRUCTIONS DO NOT APPLY TO PMA PARTS. EQUIPMENT FAILURE COULD OCCUR IF LYCOMING INSTRUCTIONS ARE USED TO INSTALL PMA PARTS. DAMAGES RELATED TO THE INSTALLATION OF PMA PARTS COULD VOID THE WARRANTY.

Lycoming Engines recommends these engines be assembled, maintained, and overhauled using only genuine Lycoming parts. (PMA parts have not been approved for use by Lycoming Engines.)

Refer to the applicable parts catalog for genuine Lycoming parts.

Before installing a component, complete a check of the shelf-life of the part as per the latest revision of Service Letter No. L247.

This page intentionally left blank.

05-10 - TIME LIMITS / SERVICE CHECKS

1. Engine Inspection Schedule for IO-390-C Series Engines

A. Engine inspections are based on time intervals as shown in the Engine Inspection Schedule below.

NOTICE: More frequent inspections could be necessary for engines operated in particulate-laden or extremely humid, cold, damp environments.

Inspections in this manual apply to the engine and not to the aircraft. Refer to the aircraft manufacturer's maintenance manual for inspection information on aircraft components. For all engine accessory inspections, refer to the individual service requirements from each manufacturer and Supplemental Type Certificates (STCs).

Engine Inspection Schedule for IO-390-C Engines	
When to Complete inspection	Refer to Chapter 5-20
During engine servicing or maintenance	Visual Inspection
Initial 10-hour engine inspection (for new, rebuilt, or overhauled engines)	10-hour Initial Engine Inspection
<ul style="list-style-type: none"> • <i>After the first 25 hours of operation or the first 4 months since the engine was placed into service (whichever occurs first)</i> • If one or more new engine cylinders and/or piston rings have been installed • If the rate of oil consumption has not stabilized. 	25-hour Engine Inspection
<u>NOTICE:</u> The engine can have either an oil filter or an oil pressure screen. Refer to "Oil Servicing Schedule" in Chapter 12-10.	
After every 50 hours of operation or every 4 months	50-hour Engine Inspection
After every 100 hours of operation or annually	100-hour or Annual Engine Inspection
After every 400 hours of operation	400-hour Engine Inspection
After every 500 hours of operation	500-hour Engine Inspection
After every 1000 hours of operation	1000-hour Engine Inspection
Time Between Overhaul (TBO) Lycoming Engines recommends engines be sent to the factory for overhaul.	Refer to the latest revision of Service Instruction No. SI-1009 for any changes or special circumstances for the recommended TBO.

NOTICE: An Operational Ground Check must be completed prior to and after each inspection, after maintenance, and after engine overhaul. Refer to Chapter 72-00.

This page intentionally left blank.

05-20 - REQUIRED ENGINE INSPECTIONS FOR IO-390-C SERIES ENGINES

1. Engine Inspections


- A. As shown in the Engine Inspection Schedule in Chapter 05-10, the scope of engine inspections includes visual observations during engine servicing or maintenance as well as inspections based on progressive time intervals after the engine is put into service.
- B. All engine inspections are mandatory and must be completed no later than 10 hours after the specified time interval for the inspection. Refer to FAR 91-409 for additional requirements.

NOTICE: More frequent inspections could be necessary for engines operated in particulate-laden or extremely humid, cold, damp environments.

Obey and follow inspection checklists and instructions in this chapter in addition to maintenance guidelines from the aircraft manufacturer or component manufacturers that have a Supplemental Type Certificate (STC).


2. Visual Inspection for IO-390-C Series Engines

- A. Complete the Visual Inspection, with the engine installed in the aircraft, before the initial 10-hour inspection and each routine 25, 50, 100, 400, 500, and 1000-hour inspection and every time before you service, maintain, clean, or disassemble the engine.

 WARNING: BEFORE ANY ENGINE INSPECTION OR SERVICE PROCEDURE, MAKE SURE THE IGNITION SWITCH IS SET TO OFF AND THAT ALL POWER TO THE ENGINE IS DISCONNECTED. ENSURE ALL OBJECTS/PERSONNEL ARE CLEAR OF THE PROPELLER'S ROTATIONAL ARC. IF POWER IS ON, A LOOSE OR BROKEN WIRE CAN CAUSE THE ENGINE TO START AND THE PROPELLER TO TURN WHICH CAN LEAD TO DEATH OR SERIOUS INJURY OR A PROPELLER STRIKE.

B. Visual Inspection

- (1) Set all ignition and electrical switches to the OFF position.
- (2) Per the aircraft manufacturer's instructions, remove the engine cowling from the aircraft for access to the engine and its compartment.

 CAUTION: IF VOLCANIC ASH IS SUSPECTED ON THE ENGINE, DO NOT TOUCH IT WITH BARE HANDS OR GET IT IN YOUR EYES. WEAR PERSONAL PROTECTIVE EQUIPMENT. DO NOT USE WATER TO RINSE IT OFF. THE VOLCANIC ASH CAN CONTAIN ACIDIC COMPOUNDS WHICH MUST NOT BE INHALED OR TOUCHED SINCE IT CAN CAUSE INJURY. REFER TO THE "VOLCANIC ASH REMOVAL" PROCEDURE IN CHAPTER 05-30.

- (3) Copy and complete the Visual Inspection Checklist in this chapter for IO-390-C Series engines each time this inspection is done as a record of engine service. Record the engine hours.

Visual Inspection Checklist for IO-390-C Series Engines

Engine Model Number _____ Engine Serial Number: _____
 Engine Time: _____ Date Inspection Done: _____
 Inspection done by: _____

Item	Comments	Findings/ Corrective Action	Done
Engine Compartment			
Look for and remove unwanted dirt, dust, sand, or particles on the engine and in its compartment.			
If the engine has been exposed to volcanic ash, remove the volcanic ash and particulate contamination.	Refer to the section “Volcanic Ash Removal” in Chapter 05-30.		
Examine all hoses, lines, connections, wiring, fittings, and baffles for loose connections and any damage.	Tighten any loose hardware as per the Standard Torque Tables in the latest revision of the <i>Service Table of Limits - SSP-1776</i> . Replace field serviceable damaged components. Otherwise, send the engine to Lycoming Engines for repair.		
Examine the cowling and baffles for damage and correct installation	Replace damaged cowling or baffles in accordance with aircraft Original Equipment Manufacturer (OEM) procedures.		
Examine the cowling, engine and its compartment for evidence of fluid leaks, residues, or discoloration.	Identify and correct the cause of any leak, residue or discoloration.		
Examine the intercyylinder baffles for damage or looseness.	Replace a damaged or loose intercyylinder baffle. Refer to the “Intercylinder Baffle Removal” procedure in Chapter 72-30.		

Visual Inspection Checklist for IO-390-C Series Engines (Cont.)			
Item	Comments	Findings/ Corrective Action	Done
Lubrication System			
NOTICE: On new, rebuilt, or overhauled engines, during the first 50 hours of engine operation, operate this engine on mineral oil until oil consumption has stabilized.			
Examine the oil pressure relief valve, thermostatic oil cooler bypass valve, oil filter and oil sump drain plug to verify they are in satisfactory condition. Ensure that all components are secure on their respective mountings, all associated hose connections are secure and that there is no evidence of leakage.	Refer to Chapters 12-10 and 72-50. Identify and correct the cause of any leak.		
Make sure the safety wire or safety cable is secure and correctly installed on the thermostatic oil cooler bypass valve, oil filter and oil sump drain plug.	Refer to Chapters 12-10 and 72-50.		
Examine all oil lines for leaks, wear, and secure attachment. Make sure that all lines and associated cushion clamps are secure and cannot move or vibrate excessively. Ensure that there are no sharp bends in the oil line routing and that no lines are near heat sources that could damage them.	Identify and correct the cause of any leak. Refer to the "Oil Line Inspection" procedure in Chapter 72-50. Correct any problem before flight to make sure the engine operates correctly to specifications in the <i>IO-390-C Series Engine Installation and Operation Manual</i> .		
Fuel System			
NOTICE: As needed, set fuel controls on new, rebuilt, or overhauled engine to 50 to 100 rpm higher than usual idle speed (600 to 700 rpm) for the first 25 hours of operation - then adjust to the usual setting after the first 25 hours of operation.			
Examine all fuel lines for leaks, wear, and secure attachment. Make sure that all fuel lines have serviceable cushioned clamps securely attached to hold the fuel lines securely in place to prevent excessive vibration. Make sure that there are no sharp bends in the fuel line routing and that the fuel lines are not near heat sources that could damage the fuel line.	Identify and correct the cause of any leak. Refer to the "Fuel Line Inspection" procedure in Chapter 73-10.		

Visual Inspection Checklist for IO-390-C Series Engines (Cont.)				
Cylinders - Refer to figures in Chapter 72-30.				
Item to Examine	Cyl. 1	Cyl. 2	Cyl. 3	Cyl. 4
NOTICE: During the first hours of service, engines can have some leakage at the cylinder base or the cylinder base studs. This initial leakage is not harmful or detrimental to the engine.				
Oil leakage - Identify and correct the cause.	Yes No	Yes No	Yes No	Yes No
Exhaust or combustion residue - Identify and correct the cause.	Yes No	Yes No	Yes No	Yes No
Examine the cylinders for heat damage i.e. burnt paint and damaged fins. (Identify whether the paint has scaled or peeled from discolored and blistered paint appearance. Unburned metallic surfaces appear bright or clean with definite edges.) - Identify and correct the cause.	Yes No	Yes No	Yes No	Yes No
Examine the exhaust system, exhaust flange and port connections for leaks in connections between the exhaust system and exhaust ports of cylinders - look for burnt paint around the spark plug and exhaust flange bosses or for light gray deposits near the leaks; look for a warped exhaust flange (which can cause a leak.) - Identify and correct the cause. Replace exhausts that have a warped flange.	Yes No	Yes No	Yes No	Yes No
Examine studs on the cylinder head for looseness or damage. Replace loose or damaged studs.	Yes No	Yes No	Yes No	Yes No
Examine the following for cracks, rust/pitting and damage - replace cracked, rusted, pitted or damaged cylinders.				
External cylinder barrel and cooling fins.	Yes No	Yes No	Yes No	Yes No
External surface of the cylinder head and fins including areas between and adjacent to the fins.	Yes No	Yes No	Yes No	Yes No
Look for any radial fin crack extending to the root of a fin on the cylinder.	Yes No	Yes No	Yes No	Yes No
Top and bottom spark plug bosses.	Yes No	Yes No	Yes No	Yes No
Follow-Up Action:				

Visual Inspection Checklist for IO-390-C Series Engines (Cont.)			
Item	Comments	Findings/ Corrective Action	Done
Crankcase			
Examine the external surface of the crankcase for damage, cracks.	Replace a damaged or cracked crankcase. Replace the crankcase if there is any raised metal on surfaces. Replace the crankcase if there is any scratch, ding, dent, or pit that exceeds 0.050 in. (1.27 mm) depth.		
Accessories and Accessory Housing			
Examine the accessory housing and its attached accessories for damage.	Replace damaged accessories or accessory housing.		
Visually examine the alternator, alternator belt, and attaching hardware.	Refer to Chapter 72-70.		
Wiring Harness			
Examine the wiring harness for correct attachment to the electrical connectors and engine. Look for broken or frayed wire, signs of chafing, deterioration, abrasion or heat-related damage.	Replace the wiring harness if it is frayed, broken, chafed, abraded, or damaged per the aircraft manufacturer's instructions.		
Make sure wiring harness clamps are secure and not worn or damaged. Tighten any loose clamps. Replace any worn or damaged clamps.			
Make sure that securing straps, and lockwiring are attached correctly and tightly.			
Induction System			
Make sure that the induction system is in satisfactory condition. Ensure that all clamps and hardware are securely fastened and that there is no evidence of leakage or staining.	Refer to the "Induction System Inspection" in Chapter 72-80.		
In accordance with the aircraft manufacturer's instructions, examine the induction air filter for cleanliness, security, and indications of damage.			

Visual Inspection Checklist for IO-390-C Series Engines (Cont.)			
Item	Comments	Findings/ Corrective Action	Done
Engine Controls			
Examine all engine controls for general condition, full travel, and freedom of operation in accordance with the aircraft manufacturer's instructions			
Follow-Up Action:			

- (4) Make sure items in the engine compartment are securely in place and not loose. Remove any foreign object debris (FOD) from the engine compartment.
- (5) Start the engine and run-up per instructions in the *IO-390-C Series Engine Installation and Operation Manual*.
- (6) Operate the engine for 3 minutes on the ground (per the *IO-390-C Series Engine Installation and Operation Manual*). Complete a leak check while the engine is in operation.
- (7) Shut down the engine.
- (8) Copy and complete the Operational Leak Check Sheet for IO-390-C Series engines on the next page.
- (9) Identify and correct all leaks. Record all leaks and corrective action on the Operational Leak Check Sheet for IO-390-C Series Engines.
- (10) Re-install the engine cowling per the aircraft manufacturer's instructions.

Operational Leak Check Sheet for IO-390-C Series Engines			
Engine Model Number _____		Engine Serial Number: _____	
Engine Time: _____		Date Inspection Done: _____	
Inspection done by: _____			
Item	Comments	Findings/ Corrective Action	Done
Examine the cowling, engine and its compartment for evidence of fluid leaks, residue, or discoloration.	Identify and correct the cause of any leak, residue, or discoloration.*		
Examine all oil lines for leaks, wear, and secure attachment. Make sure that the oil lines are securely attached to prevent vibration. Make sure that there are no sharp bends in the oil line routing and that the oil lines are not near heat sources that could damage the oil line.	Identify and correct the cause of any leak.* Refer to the "Oil Line Inspection" procedure in Chapter 72-50.		
Examine all fuel lines for leaks, wear, and secure attachment. Make sure that all fuel lines have serviceable cushioned clamps securely attached to hold the fuel lines securely in place to prevent excessive vibration. Make sure that there are no sharp bends in the fuel line routing and that the fuel lines are not near heat sources that could damage the fuel line.	Identify and correct the cause of any leak.* Refer to the "Fuel Line Inspection" procedure in Chapter 73-10.		
* For possible causes and corrections, refer to the section "Fault Isolation Guide" in Chapter 12-30.			

3. 10-Hour Initial Engine Inspection for IO-390-C Series Engines
 - A. Complete this inspection after the first 10 hours of initial operation of a new, rebuilt, or overhauled engine.
 - B. Copy and complete the 10-Hour Initial Engine Inspection Checklist for IO-390-C Series engines as a record of engine service. Record the engine hours.

⚠ WARNING: BEFORE ANY ENGINE INSPECTION OR SERVICE PROCEDURE, MAKE SURE THE IGNITION SWITCH IS SET TO OFF AND THAT ALL POWER TO THE ENGINE IS DISCONNECTED. ENSURE ALL OBJECTS/PERSONNEL ARE CLEAR OF THE PROPELLER’S ROTATIONAL ARC. IF POWER IS ON, A LOOSE OR BROKEN WIRE CAN CAUSE THE ENGINE TO START AND THE PROPELLER TO TURN WHICH CAN LEAD TO DEATH OR SERIOUS INJURY OR A PROPELLER STRIKE.

NOTICE: Copy the blank checklist and complete this checklist as a record of engine maintenance. Put the completed checklist in the engine logbook.

10-Hour Initial Engine Inspection Checklist for IO-390-C Series Engines			
Engine Model Number _____		Engine Serial Number: _____	
Engine Time: _____		Date Inspection Done: _____	
Inspection done by: _____			
Inspection Item	Comments	Results/Notes	Done
NOTICE: As needed, set fuel controls on new, rebuilt, or overhauled engine to 50 to 100 rpm higher than usual idle speed (600 to 700 rpm) for the first 25 hours of operation - then adjust to the usual setting after the first 25 hours of operation.			
Complete the Operational Ground Check in Chapter 72-00.	Look for leaks. Identify and correct the cause of any leak. Correct any problem to make sure the engine operates correctly to specifications in Appendix A of the <i>IO-390-C Series Engine Installation and Operation Manual</i> .		

4. 25-Hour Engine Inspection for IO-390-C Series Engines

- A. The purpose of this inspection is to measure the oil level and oil consumption, replace the oil filter or clean the oil pressure screen, complete an initial oil change, identify and correct the cause of any oil leak.
- B. Complete this 25-Hour Engine Inspection at the following times:
 - After 25 hours of engine operation or the first 4 months since the engine was placed into service (whichever comes first) per Chapter 12-10
 - 25 hours after one or more new engine cylinders and/or piston rings have been installed
 - If the rate of oil consumption has not stabilized

NOTICE: Refer to the “Oil Servicing Schedule” in Chapter 12-10.

- C. Copy and complete the 25-hour Engine Inspection Checklist for IO-390-C Series engines as a record of engine service. Record the engine hours.

⚠ WARNING: BEFORE ANY ENGINE INSPECTION OR SERVICE PROCEDURE, MAKE SURE THE IGNITION SWITCH IS SET TO OFF AND THAT ALL POWER TO THE ENGINE IS DISCONNECTED. ENSURE ALL OBJECTS/PERSONNEL ARE CLEAR OF THE PROPELLER’S ROTATIONAL ARC. IF POWER IS ON, A LOOSE OR BROKEN WIRE CAN CAUSE THE ENGINE TO START AND THE PROPELLER TO TURN WHICH CAN LEAD TO DEATH OR SERIOUS INJURY OR A PROPELLER STRIKE.

25-Hour Engine Inspection Checklist for IO-390-C Series Engines			
Engine Model Number _____		Engine Serial Number: _____	
Engine Time: _____		Date Inspection Done: _____	
Inspection done by: _____			
Inspection Item	Comments	Results/Notes	Done
Complete the Visual Inspection Checklist in this chapter.	Refer to the section “Visual Inspection for IO-390-C Series Engines” in this chapter.		
Complete the Operational Ground Check in Chapter 72-00.	Make sure the engine operates correctly to specifications.		
Measure and record the oil level.	Refer to the section “Oil Level Check” in Chapter 12-10.		
Calculate oil consumption.	Refer to the “Oil Consumption “ section in Chapter 12-10 Complete this 25-hour inspection again until oil consumption stabilizes.		
Complete an initial oil change.	Refer to the section "Oil Change Procedure" in Chapter 12-10.		

25-Hour Engine Inspection Checklist for IO-390-C Series Engines (Cont.)			
Inspection Item	Comments	Results/Notes	Done
<p>⚠ WARNING: EXAMINE THE OIL PRESSURE SCREEN OR THE FILTER ELEMENT OF THE OIL FILTER FOR UNWANTED METAL PARTICLES. CLEAN THE OIL PRESSURE SCREEN. A CLOGGED OIL PRESSURE SCREEN CAN CAUSE ENGINE FAILURE.</p>			
Remove, examine, clean and install the oil pressure screen (or replace the oil filter on the initial oil change).	Refer to the section in Chapter 12-10: "Oil Pressure Screen Removal/Inspection/Cleaning/Installation" or "Oil Filter Replacement."		
<p>⚠ WARNING: EXAMINE THE OIL SUCTION SCREEN FOR UNWANTED METAL PARTICLES. REMOVE ANY CLOGS OR BLOCKAGES IN THE SUCTION SCREEN.</p>			
Remove, examine and clean the oil suction screen at the oil sump; install the oil suction screen.	<p>If blockage is found, record and identify the blockage (metal, carbon, etc.)</p> <p>Remove any blockage and clean the oil suction screen. Refer to the section "Oil Suction Screen Removal/Inspection/Cleaning/Installation" in Chapter 12-10.</p>		
<p>Examine the engine for fuel or oil leaks.</p> <p>NOTICE: During the first hours of service, engines can have some leakage at the cylinder base. This initial leakage is not harmful or detrimental to the engine.</p>	Complete the "Oil Leak Check" procedure in Chapter 12-10.		
Examine the engine for dirt, particulate, sand, or other contamination.	Remove any dirt, particulate, sand, or other contamination per Chapter 5-30.		
Re-torque the exhaust flange nuts after the first 25-hours of engine operation.	Refer to Chapter 78-00.		

25-Hour Engine Inspection Checklist for IO-390-C Series Engines (Cont.)			
Inspection Item	Comments	Results/Notes	Done
General			
<u>NOTICE:</u> If the fuel controls were set to idle 50 to 100 rpm higher than usual on new, rebuilt or overhauled engines for the first 25 hours of operation, adjust the fuel controls to the usual idle speed between 600 and 700 rpm.			
Adjust the fuel controls to the usual setting after the first 25 hours of operation.	Refer to “Idle Speed and Mixture Adjustment” in Chapter 72-00.		
Complete another Operational Ground Check in Chapter 72-00.	Correct any problem before flight to make sure the engine operates correctly to specifications*.		
* Appendix A of the <i>IO-390-C Series Engine Installation and Operation Manual</i> .			

5. 50-Hour Engine Inspection for IO-390-C Series Engines
 - A. The purpose of this inspection is to make sure that the engine operates correctly.
 - B. Complete the 50-Hour Engine Inspection after every 50 hours of engine operation or every 4 months (whichever occurs first).
 - C. Copy and complete the 50-hour Engine Inspection Checklist for IO-390-C Series Engines as a record of engine service. Record the engine hours.

⚠ WARNING: BEFORE ANY ENGINE INSPECTION OR SERVICE PROCEDURE, MAKE SURE THE IGNITION SWITCH IS SET TO OFF AND THAT ALL POWER TO THE ENGINE IS DISCONNECTED. ENSURE ALL OBJECTS/PERSONNEL ARE CLEAR OF THE PROPELLER'S ROTATIONAL ARC. IF POWER IS ON, A LOOSE OR BROKEN WIRE CAN CAUSE THE ENGINE TO START AND THE PROPELLER TO TURN WHICH CAN LEAD TO DEATH OR SERIOUS INJURY OR A PROPELLER STRIKE.

50-Hour Engine Inspection Checklist for IO-390-C Series Engines			
Engine Model Number _____		Engine Serial Number: _____	
Engine Time: _____		Date Inspection Done: _____	
Inspection done by: _____			
Inspection Item	Comments	Results/Notes	Done
Complete the Visual Inspection Checklist in this chapter.	Refer to the section “Visual Inspection for IO-390-C Series Engines” in this chapter.		
Complete the Operational Ground Check in Chapter 72-00.	Make sure the engine operates correctly to specifications.*		
NOTICE: On new, rebuilt, or overhauled engines, during the first 50 hours of engine operation, operate this engine on mineral oil until oil consumption has stabilized.			
Calculate oil consumption.	Refer to the “Oil Consumption“ section in Chapter 12-10 Complete the 25-hour inspection again until oil consumption stabilizes.		
NOTICE: If the engine has an oil pressure screen (instead of an oil filter) clean the oil pressure screen every 25 hours per the “25-Hour Engine Inspection Checklist for IO-390-C Series engines.”			
On an engine with an oil filter, complete an oil change and oil filter replacement.	Refer to the sections in Chapter 12-10: "Oil Change Procedure" and "Oil Filter Replacement."		
* Appendix A of the <i>IO-390-C Series Engine Installation and Operation Manual</i> .			

50-Hour Engine Inspection Checklist for IO-390-C Series Engines (Cont.)			
Inspection Item	Comments	Results/Notes	Done
Remove, examine, clean and install the oil suction screen at the oil sump. Replace the oil suction screen if distorted, deformed or open areas are found in the mesh.	If blockage is found, record and identify the blockage (metal, carbon, etc.) Refer to the section in Chapter 12-10: "Oil Suction Screen Removal/Inspection/Cleaning/Installation."		
Ignition System			
Make sure that the P-leads are securely attached to the magneto condenser studs. Torque the P-lead nut to 13 to 15 in. lb (1.5 to 1.7 Nm) as necessary.	Refer to the aircraft manufacturer's recommendations to make sure the ignition switch and P-lead are operating correctly.		
Remove spark plug connector nuts and examine spark plug cable leads and ceramics for corrosion and deposits. Replace spark plugs as necessary per Chapter 74-20.	Corrosion and deposits are evidence of leaking spark plugs or of improper cleaning of the spark plug walls or connector ends. Refer to the section "Spark Plug Cleaning" in Chapter 05-30.		
Clean the cable ends, spark plug walls, and ceramics.	Refer to the section "Spark Plug Cleaning" in Chapter 05-30.		
Make sure that the spark plug connections are tight.			
Replace any broken, cracked, deformed, or corroded parts.			
Visually examine the ignition leads for evidence of chafing or deterioration per the "Ignition Harness Inspection" procedure in Chapter 74-20.	Replace any ignition leads that are worn, damaged, or broken. Refer to Chapter 74-20 for "Ignition Harness Removal" and "Ignition Harness Installation" procedures.		
Make sure that the ignition lead mounting clamps are tight.	Tighten any loose clamps.		
Induction System			
Complete the Induction System Inspection.	Refer to the "Induction System Inspection" procedure in Chapter 72-80.		

50-Hour Engine Inspection Checklist for IO-390-C Series Engines (Cont.)				
Inspection Item	Comments	Results/Notes	Done	
Engine Cylinders				
For possible causes and corrections, refer to the section “Fault Isolation Guide” in Chapter 12-30.				
Examine the rocker box covers for oil leaks.	Cyl. 1	Cyl. 2	Cyl. 3	Cyl. 4
	Yes No	Yes No	Yes No	Yes No
Examine the intercyylinder baffles for damage or looseness.	Replace a damaged or loose intercyylinder baffle. Refer to the “Intercylinder Baffle Inspection” procedure in Chapter 72-30.			
Alternator				
Make sure the alternator belt support brackets and mountings are tight.	Tighten all loose hardware per torque values in the Standard Torque Tables in the latest revision of the <i>Service Table of Limits - SSP-1776</i> .			
Exhaust System				
Examine the exhaust system.	Refer to the "Exhaust System Inspection" procedure in Chapter 78-00.			
Operational Test				
Complete an Operational Ground Check in Chapter 72-00.				

6. 100-Hour or Annual Engine Inspection for IO-390-C Series Engines

NOTICE: Refer to the aircraft manufacturer’s recommendation as to whether this inspection is to be completed every 100 hours of engine operation or annually.

- A. The purpose of this inspection is to examine the ignition, magnetos, electrical systems, the engine cylinders, and the exhaust system.
- B. Complete the 100-Hour Engine Inspection after the first 100 hours of operation since the engine has been in service and then after every 100 hours of operation or during each annual aircraft inspection (whichever occurs first).
- C. Copy and complete the 100-hour or Annual Engine Inspection Checklist for IO-390-C Series engines as a record of engine service. Record the engine hours.

⚠ WARNING: BEFORE ANY ENGINE INSPECTION OR SERVICE PROCEDURE, MAKE SURE THE IGNITION SWITCH IS SET TO OFF AND THAT ALL POWER TO THE ENGINE IS DISCONNECTED. ENSURE ALL OBJECTS/PERSONNEL ARE CLEAR OF THE PROPELLER’S ROTATIONAL ARC. IF POWER IS ON, A LOOSE OR BROKEN WIRE CAN CAUSE THE ENGINE TO START AND THE PROPELLER TO TURN WHICH CAN LEAD TO DEATH OR SERIOUS INJURY OR A PROPELLER STRIKE.

100-Hour or Annual Engine Inspection Checklist for IO-390-C Series Engines			
Engine Model Number _____		Engine Serial Number: _____	
Engine Time: _____		Date Inspection Done: _____	
Inspection done by: _____			
NOTICE: Complete the Operational Ground Check prior to and after each inspection, after maintenance, and after engine assembly. Refer to Chapter 72-00.			
Inspection Item	Comments	Results/Notes	Done
Complete the 50-Hour Engine Inspection Checklist.	Refer to the section “50-Hour Engine Inspection for IO-390-C Series Engines” in this chapter.		
Ignition System			
⚠ WARNING: IF THE P-LEAD IS DISCONNECTED, THE MAGNETO WILL BE ON AND WILL ACTIVATE THE SPARK PLUG IF THE PROPELLER IS TURNED. TO PREVENT INJURY, MAKE SURE THAT THE P-LEAD IS SECURELY ATTACHED TO THE CONDENSER STUD.			
Make sure that the magneto-to-engine timing is correct. Adjust the timing as necessary.	Refer to the "Magneto-to-Engine Timing Check" in Chapter 74-30. The correct advance timing is stamped on the engine data plate.		
Complete a visual inspection of the magneto wiring conditions and connections, vent holes, and P-lead attachment.			

100-Hour or Annual Engine Inspection Checklist for IO-390-C Series Engines (Cont.)			
Inspection Item	Comments	Results/Notes	Done
Ignition System (Cont.)			
Clean the magneto vents to make sure that there is no obstruction.			
Make sure the magneto clamps securely attach the magneto to the engine.			
Make sure that the switch wire on the retard (left) breaker connects the retard contact points to the ignition vibrator.			
⚠ CAUTION: NEVER INSTALL A SPARK PLUG THAT HAS BEEN DROPPED.			
Remove, examine, rotate, clean, and re-gap acceptable spark plugs. Replace worn spark plugs.	Refer to Chapters 05-30 and 74-20.		
Examine each ignition lead for chafing, insulation breakdown, frayed wiring, deterioration, heat damage, wear, and cracking. Examine the ignition lead routing.	Refer to the section "Ignition Harness Inspection" in Chapter 74-20.		
Examine the continuity of the engine ground straps.	Refer to the aircraft manufacturer's instructions.		
Electrical System			
Complete the wiring inspection.	Refer to the section "Wiring Inspection" in Chapter 72-70.		
Examine the alternator belt(s).	Refer to the section "Alternator Belt Inspection" in Chapter 72-70.		
Complete a check of the alternator belt tension.	Refer to the section "Alternator Belt Tension Check/Adjustment" in Chapter 72-70.		
Examine the alternator attaching hardware for damage. Make sure that safety wire/cable and cotter pins are installed and tight.			

100-Hour or Annual Engine Inspection Checklist for IO-390-C Series Engines (Cont.)			
Inspection Item	Comments	Results/Notes	Done
Fuel System			
Complete the Fuel System Inspection.	Refer to the section "Fuel System Inspection" procedure in Chapter 73-10.		
<p>⚠ CAUTION: DO NOT ATTEMPT TO REPAIR A DAMAGED FUEL LINE. REPLACE ANY FUEL LINE THAT IS CRACKED, DENTED, OR KINKED; CRACKS CAN DEVELOP AT THE SIDE OF SHARP BENDS OR KINKS.</p>			
Examine fuel lines for correct routing, damage, leaks, dents, pits, nicks, kinks, stains caused by fuel leaks, cracks, brittleness, or chafing.	Refer to the "Fuel Line Inspection" section in Chapter 73-10.	Fuel Line 1	
		Fuel Line 2	
		Fuel Line 3	
		Fuel Line 4	
Make sure fuel lines are held securely in place using clamps with cushions.	<p>If no clamps are attached to the fuel line that was in service, replace the fuel line per instructions in Chapter 73-10.</p> <p>If cushions on clamps are deteriorated or missing, replace the clamps.</p> <p>If the clamps are loose, replace the fuel line.</p> <p>NOTICE: Plastic tie straps are not an acceptable substitute for clamps.</p>		
Examine the fuel injectors for leaks and correct installation.	Refer to the section "Fuel Injector Leak Check" in Chapter 73-10.		
Examine the fuel injector nozzle line attachments for secure connection.	Tighten any loose connections per torque values in the latest revision of the <i>Service Table of Limits - SSP-1776</i>		
Examine each fuel line between the fuel manifold and the nozzles for any evidence of physical damage and for stains caused by fuel leakage.	Replace damaged or worn fuel lines.*		

100-Hour or Annual Engine Inspection Checklist for IO-390-C Series Engines (Cont.)			
Inspection Item	Comments	Results/Notes	Done
Fuel System (Cont.)			
Examine solder joints at the end of fuel lines for cracks.	Replace cracked fuel lines.*		
Examine the flexible fuel lines.	Replace any lines that have become hard.*		
Examine gaskets, and seals for deterioration or leakage.	Replace any gaskets, or seals that are worn, damaged, or leaking.		
Crankcase			
Complete the crankcase inspection.	Refer to the “Crankcase Inspection Before disassembly” procedure in Chapter 72-20.		
Engine Accessories			
Complete the accessory drive inspection.	Refer to the “Accessory Drive Inspection” procedure in Chapter 72-60.		
Engine Mounts			
Complete the engine mount inspection.	Refer to the “Engine Mount Inspection” procedure in Chapter 72-00.		
* Refer to the “Fuel Line Replacement” procedure in Chapter 73-10.			
Cylinders			
Complete the “Visual Cylinder Inspection” procedure in Chapter 72-30. Record the results for each cylinder.			
Cylinder 1			
Cylinder 2			
Cylinder 3			
Cylinder 4			

100-Hour or Annual Engine Inspection Checklist for IO-390-C Series Engines (Cont.)			
Cylinder Compression Check			
Complete the “Cylinder Compression Check Procedure” in Chapter 72-30. Record the results for each cylinder.			
Cylinder 1			
Cylinder 2			
Cylinder 3			
Cylinder 4			
Intercylinder Baffle Inspection			
Complete the “Intercylinder Baffle Inspection” in Chapter 72-30. Record the results for each cylinder.			
Cylinder 1			
Cylinder 2			
Cylinder 3			
Cylinder 4			
Inspection Item	Comments	Results/Notes	Done
Examine all the rocker box covers for indications of oil leaks.	Identify and correct the cause of any oil leaks. For possible causes and corrections, refer to the “Fault Isolation Guide” in Chapter 12-30.		
Operational Test			
Complete an Operational Ground Check in Chapter 72-00.			

7. 400-Hour Engine Inspection for IO-390-C Series Engines

- A. Complete the 400-Hour Engine Inspection after every 400 hours of operation since the engine has been in service.
- B. The purpose of this inspection is to examine the engine cylinders and to complete a cylinder borescope inspection on each cylinder.
- C. Copy and complete the 400-Hour Engine Inspection Checklist for IO-390-C Series Engines as a record of engine service. Record the engine hours.

⚠ WARNING: BEFORE ANY ENGINE INSPECTION OR SERVICE PROCEDURE, MAKE SURE THE IGNITION SWITCH IS SET TO OFF AND THAT ALL POWER TO THE ENGINE IS DISCONNECTED. ENSURE ALL OBJECTS/PERSONNEL ARE CLEAR OF THE PROPELLER’S ROTATIONAL ARC. IF POWER IS ON, A LOOSE OR BROKEN WIRE CAN CAUSE THE ENGINE TO START AND THE PROPELLER TO TURN WHICH CAN LEAD TO DEATH OR SERIOUS INJURY OR A PROPELLER STRIKE.

400-Hour Engine Inspection Checklist for IO-390-C Series Engines			
Engine Model Number _____		Engine Serial Number: _____	
Engine Time: _____		Date Inspection Done: _____	
Inspection done by: _____			
Inspection Item	Comments	Results/Notes	Done
Complete the 100-Hour or Annual Engine Inspection Checklist.	Refer to the section “100-Hour or Annual Engine Inspection for IO-390-C Series Engines” in this chapter.		
Cylinders			
Remove the rocker box covers from all of the engine cylinders. Look for evidence of wear or broken parts in the area of the valve tips, valve keeper, springs, and spring seats. If any of these conditions are found, remove the cylinder and piston and examine for further damage.	Refer to the “Cylinder Removal” procedure in Chapter 72-30.		

400-Hour Engine Inspection Checklist for IO-390-C Series Engines (Cont.)

Complete the “Cylinder Borescope Inspection” procedure in Chapter 72-30. Record the results below for each engine cylinder.

Cylinder 1	
Cylinder 2	
Cylinder 3	
Cylinder 4	

8. 500-Hour Engine Inspection for IO-390-C Series Engines
 - A. Complete the 500-Hour Engine Inspection after every 500 hours of operation since the engine has been in service.
 - B. The purpose of this inspection is to examine the magnetos.
 - C. Copy and complete the 500-Hour Engine Inspection Checklist for IO-390-C Series Engines as a record of engine service. Record the engine hours.

⚠ WARNING: BEFORE ANY ENGINE INSPECTION OR SERVICE PROCEDURE, MAKE SURE THE IGNITION SWITCH IS SET TO OFF AND THAT ALL POWER TO THE ENGINE IS DISCONNECTED. ENSURE ALL OBJECTS/PERSONNEL ARE CLEAR OF THE PROPELLER’S ROTATIONAL ARC. IF POWER IS ON, A LOOSE OR BROKEN WIRE CAN CAUSE THE ENGINE TO START AND THE PROPELLER TO TURN WHICH CAN LEAD TO DEATH OR SERIOUS INJURY OR A PROPELLER STRIKE.

500-Hour Engine Inspection Checklist for IO-390-C Series Engines			
Engine Model Number _____		Engine Serial Number: _____	
Engine Time: _____		Date Inspection Done: _____	
Inspection done by: _____			
Inspection Item	Comments	Results/Notes	Done
Complete the 100-Hour or Annual Engine Inspection Checklist.	Refer to the section “100-Hour or Annual Engine Inspection for IO-390-C Series Engines” in this chapter.		
Ignition System			
Examine the magnetos in accordance with the magneto manufacturer's instructions.	If a magneto must be replaced, refer to the “Magneto Replacement Procedure” in Chapter 74-30.		

9. 1000-Hour Engine Inspection for IO-390-C Series Engines

- A. Complete the 1000-Hour Engine Inspection after every 1000 hours of operation since the engine has been in service.
- B. The purpose of this inspection is to examine the exhaust valves and guides on the engine cylinders.

NOTICE: If valve sticking is a problem, this inspection must be done. Refer to the section “Corrective Action for Valve Sticking” in Chapter 72-30.

If this 1000-hour inspection is completed prior to the scheduled 1000-hour inspection it must be completed 1000 hours from the time of inspection.

- C. Copy and complete the 1000-Hour Engine Inspection Checklist for IO-390-C Series Engines as a record of engine service. Record the engine hours.

⚠ WARNING: BEFORE ANY ENGINE INSPECTION OR SERVICE PROCEDURE, MAKE SURE THE IGNITION SWITCH IS SET TO OFF AND THAT ALL POWER TO THE ENGINE IS DISCONNECTED. ENSURE ALL OBJECTS/PERSONNEL ARE CLEAR OF THE PROPELLER’S ROTATIONAL ARC. IF POWER IS ON, A LOOSE OR BROKEN WIRE CAN CAUSE THE ENGINE TO START AND THE PROPELLER TO TURN WHICH CAN LEAD TO DEATH OR SERIOUS INJURY OR A PROPELLER STRIKE.

1000-Hour Engine Inspection Checklist for IO-390-C Series Engines			
Engine Model Number _____		Engine Serial Number: _____	
Engine Time: _____		Date Inspection Done: _____	
Inspection done by: _____			
Inspection Item	Comments	Results/Notes	Done
Complete the 500-Hour Engine Inspection Checklist.	Refer to the section “500-Hour Engine Inspection for IO-390-C Series Engines” in this chapter.		
Complete the “Exhaust Valve and Guide Inspection” procedure in Chapter 72-30. Record the results for each cylinder below.			
Exhaust Valve and Guide Inspection			
Cylinder 1			
Cylinder 2			
Cylinder 3			
Cylinder 4			

This page intentionally left blank.

05-30 - CLEANING

1. Cleaning Guidelines

NOTICE: The goal is to keep the engine and nacelle clean is to prevent contamination from foreign object debris (FOD) which can adversely affect engine operation.

A. Refer to Table 1 for cleaning guidelines for engine components.

⚠ CAUTION: IF VOLCANIC ASH IS SUSPECTED ON THE ENGINE, DO NOT TOUCH IT WITH BARE HANDS OR GET IT IN YOUR EYES. WEAR PERSONAL PROTECTIVE EQUIPMENT. DO NOT USE WATER TO RINSE IT OFF. VOLCANIC ASH CAN CONTAIN ACIDIC COMPOUNDS WHICH MUST NOT BE INHALED OR TOUCHED SINCE IT CAN CAUSE INJURY. REFER TO THE SECTION "VOLCANIC ASH/REMOVAL" IN THIS CHAPTER.

NOTICE: Except for parts contaminated with suspect volcanic ash, before cleaning engine parts, complete a visual inspection (per Chapter 05-20 of this manual) of engine parts to identify any stains and residues and sources thereof.

B. After the initial visual inspection in Chapter 05-20, clean engine parts thoroughly per instructions in this chapter.

⚠ CAUTION: DO NOT USE ALKALINE (CAUSTIC) CLEANING SOLUTIONS SUCH AS DETERGENTS ON ENGINE PARTS. ALKALINE SOLUTIONS REMOVE THE FINISH ON ALUMINUM PARTS AND MAGNESIUM PARTS. ALKALINE COMPOUNDS CAN GET INTO THE PORES OF THE METAL WHICH CAN CAUSE OIL FOAMING WHEN THE PART IS PUT BACK INTO SERVICE. OBEY STANDARD SAFETY PRACTICES REGARDING THE HANDLING OF CLEANING MATERIALS AND THE USE OF PERSONAL PROTECTIVE EQUIPMENT.

NOTICE: If you are not sure of the correct cleaning agent or whether the component contains aluminum or magnesium, contact Technical Support at Lycoming Engines at the phone numbers in the front of the manual.

C. Cleaning processes include: degreasing and decarbonizing.

(1) Degreasing removes dirt and sludge (soft carbon). Soak the component or part in mineral spirits or other degreaser. Refer to the "Soft Carbon Removal" procedure in this chapter.

⚠ CAUTION: DO NOT USE ANY HEATED DECARBONIZING SOLVENT ON ALUMINUM OR MAGNESIUM PARTS. THE DECARBONIZING SOLVENT CAN DAMAGE OR CORRODE MAGNESIUM AND ALUMINUM PARTS.

(2) Decarbonizing removes hard carbon with an initial soak of the part in a warm or heated decarbonizing solution. After the soak, use a (non-wire) bristle brush, wooden scraper, or grit-blasting (with non-abrasive media as per the "Grit-Blasting" procedure in this chapter) to physically remove the hard carbon. Refer to the "Hard Carbon Removal" procedure in this chapter.

NOTICE: Since decarbonizing can remove most of the enamel from exterior surfaces, remove any remaining enamel by grit-blasting.

**Table 1
Cleaning Guidelines for Engine Components**

Component or Part	Cleaning Agent*	Guidelines
Crankshaft	Mineral spirits, MIL-PRF-680 or equivalent	Refer to the “Crankshaft Cleaning” procedure in this chapter
Crankshaft Counterbore	Mineral spirits, MIL-PRF-680 or equivalent or Stoddard Solvent	Refer to the “Crankshaft Counterbore Cleaning” procedure in this chapter
Crankshaft Gear	Mineral spirits, MIL-PRF-680 or equivalent or Stoddard Solvent	Refer to the “Crankshaft Gear Cleaning” procedure in this chapter.
Camshaft	Mineral spirits, MIL-PRF-680 or equivalent	
Tappets	Petroleum-based solvent	Refer to the “Tappet Cleaning” procedure in this chapter.
Crankcase	Petroleum-based solvent	Refer to the “Crankcase Cleaning” procedure in this chapter.
Removal of silk thread and/or gasket material from crankcase mating flanges	Methyl-Ethyl-Ketone (MEK) Acetone Napsco SC-200 M-17 M-114	
Accessory Housing		Refer to the “Soft Carbon Removal” procedure in this chapter
Cylinders	Mineral spirits (MIL-PRF-680), kerosene or equivalent degreasing agent	Refer to the “Cylinder Cleaning” procedure in this chapter.
Deposits in cylinder combustion chamber		Refer to the “Grit-Blasting the Combustion Chamber in an Engine Cylinder” procedure in this chapter.
Connecting Rods	Mineral spirits, MIL-PRF-680 or equivalent	
Interior surfaces of aluminum parts with hard carbon or oil varnish (gum) deposits	Petroleum-based Decarbonizing solutions (Gunk [®] , Penetrol [®] , or equivalent)	Refer to the “Hard Carbon Removal” procedure in this chapter.
Valve rockers	Mineral spirits (MIL-PRF-680), kerosene or equivalent degreasing agent	Clean with Scotch-Brite [™] or equivalent. Remove debris with clean lint-free wipes.
Stabilizers, valve components, starter drive, fuel control inlet screen	Mineral spirits (MIL-PRF-680), kerosene or equivalent degreasing agent	

**Table 1 (Cont.)
Cleaning Guidelines for Engine Components**

Component or Part	Cleaning Agent*	Guidelines
Piston	Mineral spirits (MIL-PRF-680), Safety Solvent or equivalent degreasing agent	Refer to the “Piston Cleaning” procedure in this chapter.
Small steel parts	Mineral Spirits Cold Dip Tanks (or closed tank system) and use NALCO 1704	Refer to the “Steel, Aluminum or Magnesium Parts Cleaning” procedure in this chapter.
Large steel parts covered with light oil	Oil-based solvent: mineral spirits, Stoddard Solvent or equivalent	Refer to the “Steel, Aluminum or Magnesium Parts Cleaning” procedure in this chapter.
Aluminum or magnesium parts		Refer to the “Steel, Aluminum or Magnesium Parts Cleaning” procedure in this chapter.
Oil Pump Oil sump	Mineral spirits, MIL-PRF-680 or equivalent	
Oil pressure screen Oil suction screen	Mineral spirits, MIL-PRF-680 or equivalent degreasing solvent	Refer to Chapter 12-10 for additional details.
Thermostatic oil cooler bypass valve	Mineral spirits, MIL-PRF-680 or equivalent degreasing solvent	<p align="center">⚠ CAUTION:</p> <p align="center">DO NOT USE RAGS OR ANY LINT CLOTH TO CLEAN THIS VALVE.</p> <p>Soak the thermostatic oil cooler bypass valve in filtered mineral spirits (or equivalent).</p>
Spark plugs	Commercially available spark plug cleaner.	Refer to spark plug manufacturer’s cleaning instructions.
Spark plug lead connector, cable ends, and ceramics	MEK Acetone Wood Alcohol (Methyl Alcohol or Methanol) Naphtha or equivalent	Refer to the “Spark Plug Cleaning” procedure in this chapter.
Lead deposits		Refer to the “Lead Deposit Removal” procedure in this chapter.
Removal of gasket material	MEK Acetone Naphtha or equivalent	<p>Apply solvent to gasket material</p> <p>Use wooden scraper to remove gasket material.</p> <p>Wipe away all debris with clean lint-free wipe.</p>

**Table 1 (Cont.)
Cleaning Guidelines for Engine Components**

Component or Part	Cleaning Agent*	Guidelines
Precision fuel injector nozzles	Hoppes [®] No. 9 Gun Cleaning Solvent, Alkon Cleaner, MEK, Acetone	Refer to the “Injection Nozzle Cleaning” section in this chapter.
AVStar fuel injector nozzles	MEK, Acetone	Refer to the “Injection Nozzle Cleaning” section in this chapter.
Fuel filter screen, fuel servo inlet screen	MEK, Acetone	(1) Clean in an ultrasonic cleaner. (2) Blow dry with compressed air.
Fuel pump plunger	Cold Dip Tanks (or closed tank system) and use NALCO 1704	Refer to the “Steel, Aluminum or Magnesium Parts Cleaning” procedure in this chapter.
Electrical connectors	CR4 or equivalent	Refer to contact cleaning solvent manufacturer’s instructions.
Hartzell Engine Technologies (HET) (formerly Kelly Aerospace) starter		Refer to starter manufacturer’s cleaning instructions.
All other parts	Parts washer solvent using Whirlwash-L or equivalent	
Volcanic ash on engine		Refer to the “Volcanic Ash Removal” procedure in this chapter.
*Refer to the manufacturer’s instructions for usage, safety data, and disposal of all cleaning agents.		

2. Crankshaft Cleaning

⚠ CAUTION: DO NOT MAKE SCORES, SCRATCHES, OR ETCH MARKINGS OF ANY KIND ON THE CRANKSHAFT SINCE THEY CAN CAUSE THE PART TO WEAKEN AND TO FAIL.
DO NOT USE WIRE BRUSHES OR METAL SCRAPERS ON BEARINGS OR CONTACT SURFACES.

- A. Clean the inside of all crankpin journals, main bearing journals, and all oil passages with the bristle (non-wire) brushes.
- B. Clean all parts thoroughly with mineral spirits (MIL-PRF-680) or equivalent.
- C. Dry the crankshaft with compressed air.
- D. Apply preservative oil to the crankshaft to prevent corrosion.

3. Crankshaft Counterbore Cleaning

- A. Flush the crankshaft counterbore and alignment dowel pin with mineral spirits (MIL-PRF-680) or equivalent or Stoddard's Solution or equivalent solvent to remove any debris.
- B. Dry the crankshaft counterbore threads with compressed air.
- C. Examine the threads in the crankshaft counterbore for any wear.

- D. Make sure the tapped hole is clean and the threads are not stripped, galled, or damaged. If the threads are stripped, galled, or damaged, discard the crankshaft and replace it with a new crankshaft.
- E. Clean the threads of the recessed counterbore on the crankshaft as follows:
 - (1) Use the correct sized undamaged bottoming tap for a 5/16-24 thread size.

⚠ CAUTION: TO PREVENT MAKING THE THREADS IN THE CRANKSHAFT COUNTERBORE TOO LARGE, USE THE CORRECTLY SIZED TAP. IF THE INCORRECT TAP IS USED, THE BORE CAN BE MADE TOO LARGE TO CORRECTLY ENGAGE THE THREADS ON THE GEAR BOLT WHEN THE CRANKSHAFT GEAR IS INSTALLED ON THE CRANKSHAFT. IF THE BOLT THREADS ARE TOO LARGE, DISCARD THE CRANKSHAFT AND REPLACE IT WITH A NEW CRANKSHAFT.

- (2) Install the tap into the recessed counterbore on the crankshaft.
 - (3) Turn the tap as necessary to clean the threads.
 - (4) Remove the tap.
 - (5) Flush the crankshaft counterbore and alignment dowel pin with mineral spirits (MIL-PRF-680) or equivalent or Stoddard's Solvent, or equivalent solvent to remove any debris.
 - (6) Dry the crankshaft counterbore threads with compressed air.
 - (7) Again, examine the threads in the crankshaft counterbore for any wear.
 - (8) Make sure the tapped hole is clean and the threads are not stripped, galled, or damaged. If the threads are stripped, galled, or damaged, discard the crankshaft and replace it with a new crankshaft.
4. Crankshaft Gear Cleaning
- A. Soak the crankshaft gear in mineral spirits (MIL-PRF-680) or equivalent or Stoddard Solvent, or equivalent solvent.
 - B. Remove all dirt and debris from the crankshaft gear with a lint-free wipe.
 - C. Dry with compressed air.
5. Tappet Cleaning
- A. Clean the tappets using the cleaning procedure in the next steps. Refer to the latest revision of Service Instructions SI-1011 and SI-1514 for details about tappets.
- NOTICE:** During disassembly and cleaning, keep the tappet parts together.
- B. Put tappets in a special cleaning basket that has separate compartments to keep the parts for each tappet as a set, identified but segregated from other tappets.
 - C. Put the cleaning basket with the tappets immersed in a petroleum-based solvent.
 - D. Flush with petroleum-based solvent and blow dry with compressed air.
- NOTICE:** If the cleaned tappets are acceptable per the "Tappet Inspection" in Chapter 72-20, they can be re-installed.
- E. Apply a light coat of engine oil to the lifter parts before tappet assembly.

6. Crankcase Cleaning

A. Grit-blast the crankcase (as necessary) to remove all coatings on the crankcase and engine mount bosses. Refer to the sections “Grit-Blasting,” “Grit-Blast Media,” and “Grit Blast Procedure” in this chapter. Make sure there is no dirt, debris, sludge, paint, or any other substance that could prevent reliable fluorescent penetrant inspection (FPI) or subsequent oil flow.

B. Remove all plugs from oil passages in the crankcase.

NOTICE: Clean the crankcase after all grit-blasting is complete.

C. Use a stiff bristle fiber (not wire) brush and clean petroleum solvent to clean and flush the oil passages.

D. Use compressed air to clean and dry the oil passages.

E. Prior to installation of a new crankshaft oil seal, clean the crankcase bore, use a clean disposable lint-free cloth and any of the following cleaning solvents to remove oil, sealant, and debris from the crankcase, especially the crankcase bore which has the groove for the crankshaft oil seal:

- Methyl-Ethyl-Ketone (MEK)
- Acetone
- Napasco SC-200
- M-17
- M-114.

CAUTION: ONLY APPLY MEK SOLVENT TO THE CRANKCASE, INCLUDING THE CRANKCASE BORE AND GROOVE FOR THE CRANKSHAFT OIL SEAL. DO NOT APPLY MEK SOLVENT TO THE CRANKSHAFT OIL SEAL SINCE MEK CAN CAUSE THE SEAL TO DETERIORATE. BE SURE THAT ALL TRACES OF CLEANING SOLVENT, OIL AND SEALANT ARE REMOVED PRIOR TO INSTALLATION OF A NEW CRANKSHAFT OIL SEAL.

7. Grit-Blasting

Do not grit-blast the following:

- Piston ring grooves and piston skirts
- Valve stems
- Valve guides
- Bearing surfaces
- Bushings
- Gears
- Any machined surface

A. Grit-Blast Media

CAUTION: DO NOT USE SAND OR METALLICALLY ABRASIVE MATERIALS TO GRIT-BLAST.

(1) During grit-blasting, use mildly abrasive blast media such as 17-grit walnut shells or equivalent.

B. Grit-Blast Procedure

CAUTION: ALWAYS REMOVE ANY COMPONENT OR PART FROM THE ENGINE BEFORE GRIT-BLASTING THE COMPONENT OR PART.

(1) To grit-blast the engine cylinders, refer to the section "Grit-Blasting the Combustion Chamber in an Engine Cylinder" in this chapter.

- (2) Hold the grit-blast gun (filled with the correct grit-blast media), a few inches away, but pointed toward the surface to be grit-blasted. Operate the grit-blast gun as per the manufacturer's instructions.
- (3) Unless otherwise specified in the manufacturer's instructions, use approximately 35 to 45 psi (241 to 310 kPa) of air pressure during grit-blasting.
- (4) Use compressed air and the vacuum cleaner to remove any debris and residue.
- (5) After all cleaning is complete:
 - (a) Rinse the part in a petroleum solvent.
 - (b) Dry the part with an air blast to remove all loose particles.
 - (c) Apply a coating of preservative oil to the entire part.
 - (d) Put cleaned oil and fuel system components in a clean sealed container until ready for assembly.
 - (e) Install clean plastic caps or covers over each open end of a cleaned hollow tube, hose or line to prevent debris from entering these areas.
 - (f) Put remaining cleaned parts on clean bench surfaces where there is no particulate, dirt, grit, or other unwanted materials to prevent contamination from FOD.

8. Soft Carbon Removal

- A. Unless otherwise directed, put the component in a bath tank fully immersed in mineral spirits or equivalent for 10 minutes.
- B. Remove the component from the bath tank.
- C. Remove any remaining soft carbon (dirt or sludge) from the component with a lint-free wipe.
- D. Apply a spray coating of preservative oil on the component to prevent corrosion.
- E. If the component is not to be installed immediately, put the component in a sealed plastic bag until installation.

9. Hard Carbon Removal

⚠ CAUTION: DO NOT PUT STEEL AND MAGNESIUM PARTS INTO THE SAME DECARBONIZING SOLUTION, BECAUSE IT CAN CAUSE CORROSION OF THE MAGNESIUM PARTS.

DO NOT USE ANY HEATED DECARBONIZING SOLVENT ON ALUMINUM OR MAGNESIUM PARTS. THE DECARBONIZING SOLVENT CAN DAMAGE OR CORRODE MAGNESIUM AND ALUMINUM PARTS.

NOTICE: If you are not sure if the component is steel or contains magnesium, contact Technical Support at Lycoming Engines at the phone numbers in the front of the manual.

⚠ CAUTION: DO NOT USE WIRE BRUSHES OR METAL SCRAPERS ON BEARING OR CONTACT SURFACES.

NOTICE: Hard carbon can remain on interior surfaces of cylinders and combustion chambers after using a degreasing solvent to clean a part.

- A. Put the component with the hard carbon fully immersed into a warm petroleum-based decarbonizing solution (examples: Gunk[®], Penetrol[®], or equivalent) in a heated bath tank or Paint and Ink Remover in an ultrasonic cleaner.

- B. Soak for 10 minutes (to loosen the hard carbon).
- C. Remove the component from the bath tank.
- D. Use a (non-wire) bristle brush, wooden scraper, or grit-blasting (with 17-grit walnut shells or equivalent as per the section “Grit-Blast Media” in this chapter) to physically remove the hard carbon.
- E. Remove any remaining hard carbon from the component with a lint-free wipe.
- F. Apply a spray coating of preservative oil on the component to prevent corrosion.
- G. If the component is not to be installed immediately, put the component in a sealed plastic bag until installation.

10. Cylinder Cleaning

- A. Clean the internal barrel of the cylinder by flushing it with a hydrocarbon-based solvent (mineral spirits MIL-PRF-680 or equivalent) under air pressure. Use a soft bristle brush in conjunction with flushing to remove abrasive build-up from areas that are otherwise difficult to reach.
- B. Remove all oil accumulation from the external sides of the cylinders by washing with mineral spirits (MIL-PRF-680), kerosene, or equivalent degreasing solvent.
- C. Thoroughly dry the cylinder with compressed air.
- D. Clean the cylinder head fin areas thoroughly with mineral spirits (MIL-PRF-680), kerosene or equivalent, to remove all traces of grease, dirt, or other foreign matter, and air dry with compressed air.
- E. Grit-Blasting the Combustion Chamber in an Engine Cylinder:
 - (1) Remove the intake and exhaust valves from the cylinder to be cleaned. Refer to Chapter 72-30.
 - (2) Remove the spark plugs from the cylinder. Refer to the section “Spark Plug Removal” in Chapter 74-20.
 - (3) Complete the "Grit-Blast Procedure" in this chapter.
 - (4) Record the cleaning for future reference to identify trends and engine operating time for lead build up to occur.
- F. Wipe the cylinder with a clean, white cloth dipped in SAE 10 engine oil. Examine the cloth after use under a light for evidence of any abrasive residue remaining in the cylinder. If any residual abrasive is found, repeat the previous step until there is no abrasive residue.

11. Piston Cleaning

⚠ CAUTION: DO NOT USE A STEEL BUFFING BRUSH TO CLEAN THE RING LANDS AND SKIRT OF A PISTON. DO NOT GRIT-BLAST PISTON GROOVES. THESE METHODS CAN STRETCH THE SIDES OF THE PISTON RING GROOVES AND ROUND OFF THE OUTER CORNER OF THE PISTON RING LANDS, WHICH AFFECTS THE PISTON CONFIGURATION.

- A. Remove all oil or preservative oil accumulation from the piston by a soak or wash in a clean bath of mineral spirits, Safety Solvent, or equivalent degreasing solvent in compliance with MIL-PRF-680 specifications.
- B. Remove any remaining deposits with a wooden scraper.

- C. Gently clean the piston pin bore with a soft bristle non-metallic brush (Figure 1). Use a gentle twist motion to clean each bore.
- D. After cleaning one side, turn the piston 180° and repeat motion to ensure the entire bore is free of FOD.
- E. Soak the piston again in a new clean bath of mineral spirits, Safety Solvent, or equivalent degreasing solvent in compliance with MIL-PRF-680 specifications to remove remaining deposits.
- F. Clean the piston ring grooves thoroughly. Make sure the piston ring grooves are completely clean and that there is no debris in the grooves.

**Figure 1**

Cleaning the Piston Pin Bore with a Soft Bristle Non-Metallic Brush

12. Injection Nozzle Cleaning

- A. Remove the injection nozzle per the “Injection Nozzle Removal” procedure in Chapter 73-10.

⚠ CAUTION: NEVER USE A SHARP TOOL SUCH AS A WIRE OR PIN TO CLEAN AN INJECTION NOZZLE. DAMAGE TO THE INLET AND OUTLET FUEL RESTRICTORS COULD OCCUR WHICH WOULD CHANGE THE FUEL FLOW.

NOTICE: There are slightly different cleaning procedures for Precision and AVStar injection nozzles. Refer to the applicable procedure to clean your injection nozzles.

Clean the Precision fuel injection nozzle with:

- Hoppes No. 9 Gun Cleaning Solvent
 - (1) Soak the nozzles in Hoppes® No. 9 Gun Cleaning Solvent for 20 minutes.
 - (2) Rinse the nozzles with Stoddard solvent and blow dry with compressed air.
- Alkon Cleaner
 - (1) The solution concentration of Alkon cleaner to water is 7 to 8 oz./gal.
 - (2) Heat the Alkon/water solution to 140°F (60°C).
 - (3) Soak the nozzles in the Alkon/Water solution for one hour.
 - (4) Rinse the nozzles with clean hot water and blow dry with compressed air.
- MEK
 - (1) Soak the nozzles in MEK for one hour.
 - (2) Rinse the nozzles with clean hot water and blow dry with compressed air.
- Acetone
 - (1) Soak the nozzles in acetone for one hour.
 - (2) Rinse the nozzles with clean hot water and blow dry with compressed air.

Clean the AVStar fuel injection nozzle with:

- MEK
 - (1) Soak the nozzles in MEK for one hour.
 - (2) Rinse the nozzles with clean hot water and blow dry with compressed air.
- Acetone
 - (1) Soak the nozzles in acetone for one hour.
 - (2) Rinse the nozzles with clean hot water and blow dry with compressed air.

- B. Install the injection nozzle per “Injection Nozzle Installation” procedure in Chapter 73-10.

13. Steel, Aluminum, or Magnesium Parts Cleaning

⚠ CAUTION: DO NOT PUT STEEL AND MAGNESIUM PARTS INTO THE SAME DECARBONIZING SOLUTION, BECAUSE IT CAN CAUSE CORROSION OF THE MAGNESIUM PARTS.

DO NOT USE ANY HEATED DECARBONIZING SOLVENT ON ALUMINUM OR MAGNESIUM PARTS. THE DECARBONIZING SOLVENT CAN DAMAGE OR CORRODE MAGNESIUM AND ALUMINUM PARTS.

ONLY USE PETROLEUM-BASED DECARBONIZING SOLUTIONS ON ALUMINUM PARTS.

DO NOT USE WATER-MIXED SOLVENTS THAT CONTAIN CAUSTIC COMPOUNDS AND/OR SOAP, BECAUSE THEY CAN CAUSE DAMAGE TO ALUMINUM AND MAGNESIUM PARTS. WHEN THE ENGINE IS RETURNED TO SERVICE, THESE MATERIALS CAN ENTER THE PORES OF THE METAL AND CAUSE OIL FOAMING.

NOTICE: If you are not sure if the component is steel or contains magnesium or aluminum, contact Technical Support at Lycoming Engines at the phone numbers in the front of this manual.

A. Put the component fully immersed in mineral spirits or equivalent in a bath tank.

NOTICE: For small steel parts, cold dip tanks or a closed tank system can be used with NALCO 1704.

B. Remove the component from the bath tank.

C. Remove any remaining soft carbon (dirt or sludge) from the component with a lint-free wipe.

D. Apply a spray coating of preservative oil on the component to prevent corrosion.

E. If the component is not be installed immediately, put the component in a sealed plastic bag to prevent the oil from drying out.

14. Spark Plug Cleaning

A. Remove the spark plug as per the “Spark Plug Removal” procedure in Chapter 74-20.

B. Refer to spark plug manufacturer’s cleaning instructions.

C. Clean the ignition lead, cable ends, spark plug walls, and ceramic of the spark plugs (new or reused) as per the spark plug manufacturer’s instructions.

D. Wipe the spark plug lead connector clean using a lint-free cloth moistened with Methyl-Ethyl-Ketone (MEK), acetone, wood alcohol, naphtha, or equivalent.

E. Remove all cleaning residue from the spark plug lead connector.

F. Install the spark plug as per the “Spark Plug Installation” procedure in Chapter 74-20.

15. Lead Deposit Removal

A. Grit-blast (the component with lead deposits) with 17 grit walnut shells or equivalent at 35 to 45 psi (241 to 310 kPa). Refer to the section “Grit-Blast Media” and “Grit-Blast Procedure” in this chapter.

B. Remove all debris from the component to prevent problems caused by foreign object debris.

16. Volcanic Ash Removal

⚠ CAUTION: DO NOT TOUCH THE VOLCANIC ASH WITH BARE HANDS OR GET IT IN YOUR EYES. WEAR PERSONAL PROTECTIVE EQUIPMENT.

DO NOT USE WATER INITIALLY TO REMOVE THE VOLCANIC ASH. WHEN VOLCANIC ASH COMES INTO CONTACT WITH WATER, IT CAN BECOME A HARDENED, CORROSIVE COMPOUND.

- A. Wear personal protective equipment (gloves, respiratory, and eye protection). Per the aircraft manufacturer's instructions, thoroughly remove the ash or particulate from the aircraft by hand brushing or air/vacuuuming. Make sure that all ash is removed from the engine and cowling.
- B. Engine exterior and components NOT contaminated with volcanic ash:
 - (1) Remove grease, oil, dirt, and soft carbon deposits from the parts.
 - (2) Spray or brush the components with a hydrocarbon-base solvent.
- C. Examine the induction filters, induction system, and engine baffles for blockage or damage.
- D. Refer to the section "Volcanic Ash/Particulate Contamination" in Chapter 05-50 for required action.
- E. Refer to the aircraft manufacturer's instructions for additional information
- F. After the engine is returned to service and has been operated for 10 hours, examine the external engine, and cowling for any remaining ash. Remove all volcanic ash.

17. Cleaning Guidelines for a Soaked Engine

When cleaning parts removed from an engine that was soaked, especially ferrous (iron) metals, do not use hot acidic cleaning agents or electrolytic cleaning methods (such as cathodic cleaning) since they can cause hydrogen embrittlement. This embrittlement can cause a metallic part to weaken and fail.

Additionally, acids can generally attack the metals and cause pitting or other corrosion damage.

When cleaning parts:

- A. Be sure to remove all cleaners.
- B. Rinse the part thoroughly.
- C. Dry the part.

There must not be any cleaning agent residue on the metal surfaces. Any chemical that could either corrode the metal or create hydrogen gas can cause hydrogen embrittlement during service.

Paint strippers are usually organic solvents like MEK or acetone or toluene, etc. and typically will not cause any damage to metals.

Except for chlorinated solvents (such as trichloroethane, trichloroethylene, "perc"-degreaser, etc), just about any other type of solvent can be used on steel or aluminum parts. Chlorinated solvents can react with moisture and produce some hydrochloric acid which could harm the metal.

18. Cleaning Method for Non-Destructive Testing

A. Remove all traces of:

- Paint
- Gasket materials
- Oil
- Grease
- Dirt
- Corrosion
- Smear metal
- Plating
- Chemical residues

B. Use any of the following cleaning methods as long as it is not harmful to the component or its intended function:

- Vapor degreasing
- Solvent degreasing
- Ultrasonic cleaning
- Chemical cleaning
- Aqueous-based cleaning
- Mechanical cleaning (such as grit blasting)

NOTICE: If grit blasting is to be used without a subsequent etching process, make sure the grit blasting does not peen the surface. Typically, a fine abrasive of 150-grit or finer is acceptable.

05-50 - UNSCHEDULED MAINTENANCE

1. Unscheduled corrective maintenance is necessary when any of the following conditions occur:
- Lightning strike
 - Engine on fire or near fire
 - Valve sticking
 - Engine overspeed
 - Hydraulic lock
 - Oil starvation/sudden loss of oil pressure
 - Incorrect fuel or fuel contamination
 - Volcanic ash/particulate contamination
 - Propeller strike, sudden engine stoppage or loss of propeller blade tip
 - Soaked engine

A. Lightning Strike - After a lightning strike:

After a lightning strike, if there is external evidence of electrical damage to the engine or propeller or evidence of magnetism of the engine or propeller, before the next flight, complete a visual inspection of the engine and propeller for electrical arc damage (in accordance with the airframe and propeller manufacturer's recommended procedures/guidance).

If there is evidence of arc damage and the engine is not past its Time Between Overhaul (TBO) per the latest revision of Service Instruction No. SI-1009, send the engine either to Lycoming Engines or an approved repair facility for an internal inspection and evaluation on whether an engine repair or overhaul is necessary.

OR

Complete the following in the field in accordance with this manual:

- (1) Remove, disassemble, and clean the engine (per Chapters 72-00, 72-05, and 05-30).
- (2) Complete an inspection of the engine and its components per chapters in this manual and the latest revision of Service Bulletin No. SB-401.
- (3) Examine the engine compartment in the aircraft, the engine, external surfaces, internal parts for discoloration, cracks, and other indications of arcing and heat damage.

NOTICE: Refer to the latest revision of Service Bulletin No. 240 which identifies certain parts that must be replaced on engine reassembly. **Do not re-install any part if it is discolored, cracked, or damaged. Replace the part with a serviceable part.**

- (4) Assemble the engine (per Chapter 72-10) and complete an Operational Ground Check (per Chapter 72-00).
- (5) Record the incidence of a lightning strike, inspection outcome, and any corrective action in the engine logbook.

B. Engine Overspeed

⚠ CAUTION: DO NOT OPERATE THE ENGINE CONTINUOUSLY AT AN OVERSPEED RATE BECAUSE PARTS CAN WEAR OUT AND EVENTUALLY CAUSE ENGINE FAILURE.

- (1) In *engine overspeed*, the engine operates above its rated (speed) revolutions per minute (rpm). *Momentary overspeed* is an increase of no more than 10% of rated engine rpm for a period not exceeding 3 seconds. No action is required for a momentary overspeed.

NOTICE: Refer to the engine specifications in Appendix A of the *IO-390-C Series Engine Installation and Operation Manual* for rated engine speed.

All incidents of engine overspeed must be recorded in the engine logbook along with any corrective action identified herein.

(2) If any engine is operated at overspeed for more than 3 seconds, identify the category of percent of overspeed based on the three categories of overspeed shown in Table 1. Refer to the latest revision of Service Bulletin No. SB-369 for additional details.

**Table 1
Overspeed Values for IO-390-C Series Engines**

Overspeed Category	rpm	Corrective Action
Engine overspeed less than 5% in excess of maximum rated rpm for more than 3 seconds	2701 to 2835	a. Identify and correct the cause of the overspeed. b. In the engine logbook, record the overspeed incident and any inspections and corrective action.
Engine overspeed between 5% and 10% in excess of maximum rated engine rpm for more than 3 seconds.	2836 to 2970	a. Identify and correct the cause of the overspeed. b. Complete the “Cylinder Overspeed Inspection” procedure in this chapter. c. Refer to Chapter 12-10: (1) Drain the lubricating system. (2) Remove oil screens and/or oil filter. (3) Examine all screens and/or oil filter in the lubrication system for metal contamination. If any unexplained metal accumulation is found, identify and correct the cause before putting the engine back into service. d. Complete the “Valve Train Overspeed Inspection” procedure in this chapter. e. Complete the “Magneto Overspeed Inspection” in this chapter. f. In the engine logbook, record the overspeed incident and any inspection and corrective action.
Engine overspeed more than 10% in excess of maximum rated engine rpm for any duration	2971 or more for any length of time	a. Remove the engine from the aircraft per the “Engine Removal Procedure” in Chapter 72-00. b. It is recommended the engine be sent to Lycoming Engines for customized evaluation. Include a description of the overspeed incident, amount of overspeed, and duration. c. In the engine logbook, make a record of the overspeed incident and any inspections and corrective action. OR Refer to Chapter 72-05 and the latest revision of Service Bulletin No. SB-240 to: <ul style="list-style-type: none"> • Disassemble the engine • Complete an inspection of the engine • Replace any parts that are damaged or not in compliance • Replace the bushings in the counterweights and crankshaft (Chapter 72-20) • Replace any other parts that must be replaced at engine overhaul or upon removal

(3) Cylinder Overspeed Inspection

- (a) Complete the cylinder compression check on all cylinders as a check for the sealing quality of the rings and valves. Refer to the section “Cylinder Compression Check Procedure” in Chapter 72-30.
- (b) Use a borescope or equivalent instrument to examine the walls of each cylinder for scoring which could be caused by a stuck or broken piston ring. Refer to the “Cylinder Borescope Inspection Procedure” in Chapter 72-30.

(4) Magneto Overspeed Inspection

- (a) Remove the magnetos per the “Magneto Removal” procedure in Chapter 74-30. Examine the magnetos for damage; replace parts as necessary per the magneto manufacturer’s instructions.
- (b) Examine the magneto drive gears for looseness which is an indication that the supporting idler shafts are loose due to failure of safety attachments.
- (c) Test the magnetos in accordance with the magneto manufacturer’s instructions.
- (d) Replace the magneto if damaged.

(5) Valve Train Overspeed Inspection

- (a) Either repeated moments or short periods of operation in the overspeed region increase the rate of wear at an accelerated pace in the parts that make up the valve train and consequently decrease engine reliability. In addition to the checks completed on the engine during a 100-hour inspection, complete the following steps to examine the valve train before putting the engine back into service.
- (b) Use a borescope or equivalent illuminated magnifying optical device to examine the condition of the intake and exhaust valve faces and seat faces. If there is evidence of excessive wear, pounding, or grooving, replace the valve and seat.
- (c) Refer to the section "Exhaust Valve and Guide Inspection" in Chapter 72-30 and the latest revision of Service Bulletin No. SB-388 to determine exhaust valve condition and stem-to-valve guide clearance condition.
- (d) Examine the external condition of valve keys, rockers, and exhaust valve guides for damage (per Chapter 72-30). Examine valve springs for coil strikes or severe bottoming of the coils. If damage to the valve springs is evident, remove them and complete the check of the compression load. Replace any valve spring that is not within limits as specified in the Special Torque Requirements Tables in Section V in Part 1 of the latest revision of the *Service Table of Limits - SSP-1776*.
- (e) Turn the crankshaft by hand to see if the valve lift is uniform or equal for all cylinders. See if valve rockers lift freely when the valves are closed. Unequal valve lift is an indication of bent push rods. Tight rockers, when valves are closed, are an indication of a tuliped valve or a damaged valve lifter. Refer to Chapter 72-30 and correct any suspected damage before putting the engine back into service.

C. Incorrect Fuel or Fuel Contamination

⚠ CAUTION: ONLY USE APPROVED FUELS IN THIS ENGINE. USE OF ANY UNAPPROVED FUEL CAN DAMAGE THE ENGINE.

⚠ WARNING: DO NOT OPERATE THE ENGINE IF JET FUEL OR A LOWER OCTANE OR INCORRECT GRADE OF FUEL. UNUSUAL DETONATION CAN INCREASE ENGINE TEMPERATURE AND PRESSURE WHICH CAN DAMAGE THE ENGINE.

- (1) Refer to the latest revision of Service Instruction No. SI-1070 and Appendix A in the *IO-390-C Series Engine Installation and Operation Manual* for approved fuels, octane ratings, and the use of a higher grade fuel for this engine.
 - (2) Actual damage to the engine from incorrect fuel could be in a range from unnoticeable to severe damage or failure. Primary damage to the engine caused by incorrect fuel occurs in the combustion chambers. Tuliped intake valves and burnt pistons from excessive cylinder head and oil temperatures are evidence of primary damage. If detonation has been severe enough, further damage will occur to crank pins, main bearings, and valve train components. The extent of damage can vary accordingly based on the duration of operation, engine power level and the type of fuel used. Refer to the latest revision of Service Bulletin No. SB-398.
 - (3) Any mixture of unapproved fuels and additive materials that change the octane rating from the specifications in Appendix A in the *IO-390-C Series Engine Installation and Operation Manual* could be harmful to the engine.
 - (4) Because of many variables, it is impossible to be sure of the airworthiness of an engine that has been operated with incorrect fuel - except by detailed inspection of the engine by qualified personnel. Therefore, if the engine has been operated with incorrect fuel, regardless of the power setting or time of operation:
 - (a) Do not continue flight and engine operation with incorrect fuel.
 - (b) Drain the aircraft fuel system until all fuel tanks are empty in accordance with the aircraft manufacturer's installation.
 - (c) If the aircraft manufacturer has a procedure for cleaning and/or purging the aircraft fuel system after the use of incorrect fuel, follow the aircraft manufacturer's procedure. If there is no aircraft cleaning and/or purging procedure, service the aircraft fuel tanks in accordance with the aircraft manufacturer's instructions.
 - (d) Remove the engine in accordance with the "Engine Removal Procedure" in Chapter 72-00.
 - (e) It is recommended the engine be sent to Lycoming Engines for evaluation.
- OR
- Complete the following in the field in accordance with this manual:
- 1 Disassemble, and clean the engine per Chapters 72-05 and 05-30.
 - 2 Complete an inspection of engine components per chapters in this manual.

- 3 During inspection of engine components, carefully look for signs of detonation such as tuliped intake valves, burnt pistons, and damage to: crankpins, main bearings, counterweights, and valve drive train components, and other conditions that can cause engine failure.

NOTICE: Refer to the latest revision of Service Bulletin No. SB-240 which identifies certain parts that must be replaced on engine reassembly.

- 4 Assemble the engine per Chapter 72-10 and complete an Operational Ground Check per Chapter 72-00.

D. Soaked Engine

⚠ CAUTION: WHEN AN ENGINE HAS BEEN SOAKED IN WATER, MOISTURE AND UNWANTED MATERIALS CAN CAUSE DAMAGE TO ALL SYSTEMS OF THE ENGINE. DO NOT INSTALL OR OPERATE AN ENGINE THAT HAS BEEN SOAKED OR IMMERSSED IN WATER OR OTHER FLUID UNTIL IT HAS BEEN DISASSEMBLED, CLEANED, EXAMINED AS NEEDED, ASSEMBLED, AND OPERATIONALLY TESTED TO ENSURE THE ENGINE CAN BE SAFELY PUT BACK INTO SERVICE.

NOTICE: The composition of the substance that the engine has been exposed to can affect the type and extent of the damage.

It is recommended the engine be sent to Lycoming Engines for evaluation. Include a description of the liquid in which the engine was soaked.

OR

NOTICE: The following inspection only applies to an engine soaked in water.

If the engine is soaked in a substance other than water, contact Lycoming Engines Technical Support.

Complete the following in the field in accordance with this manual.

- (1) Refer to the latest revision of Service Bulletin No. SB-357 for additional details.
- (2) Remove and disassemble the engine (per Chapters 72-00 and 72-05).
- (3) Clean the engine, especially all recessed areas where debris or silt can get trapped. Remove all debris and silt per the section “Cleaning Guidelines for a Soaked Engine” in Chapter 05-30.
- (4) Complete an inspection of engine components per chapters in this manual.
 - (a) Examine components for visible corrosion or rust (or evidence thereof) per Chapters 72-20 and 72-30. Where possible, remove any rust or corrosion
 - (b) Look for pitting on the cylinder and piston. If pitting is found, replace the component. Do not re-install a pitted cylinder or pitted piston.
 - (c) Visually examine components for embedded silt or debris contamination on bearing surfaces, pistons, mounting flanges, or on any porous surfaces. Remove all silt and debris from the component. If the embedded silt or debris cannot be removed, replace the component.

- (d) As per the cleaning guidelines below, clean the engine, especially all recessed areas where debris and silt can get trapped:

When cleaning parts, especially ferrous (iron) metals, do not use hot acidic cleaning agents or electrolytic cleaning methods (such as cathodic cleaning) since they can cause hydrogen embrittlement. This embrittlement can cause a metallic part to weaken and fail.

Additionally, acids can generally attack the metals and cause pitting or other corrosion damage.

When cleaning parts:

1. Be sure to remove all cleaning agents.
2. Rinse the part thoroughly.
3. Dry the part.

There must not be any cleaning agent residue on the metal surfaces. Any chemical that could either corrode the metal or create hydrogen gas can cause hydrogen embrittlement during service.

Paint strippers are usually organic solvents like MEK or acetone or toluene, etc. and typically will not cause any damage to metals.

Except for chlorinated solvents (such as trichloroethane, trichloroethylene, “perc”-degreaser, etc), just about any other type of solvent can be used on steel or aluminum parts. Chlorinated solvents can react with moisture and produce some hydrochloric acid which could harm the metal.

- (e) Replace parts per the latest revision of Service Bulletin No. SB-240 which identifies parts that must be replaced during engine assembly.
- (f) Make sure all oil passages, bored holes, oil and fuel hoses are clean and unobstructed and have no debris.
- (g) Once the engine is cleaned and reassembled, make sure it is in conformance with all required fits and clearances (per the latest revision of the ***Service Table of Limits - SSP-1776***).
- (5) Assemble the engine per Chapter 72-10.
- (6) Refer to the Airframe Maintenance Manual and make sure all airframe interface fuel and oil lines, intake, and exhaust, and the oil cooler are clean and have no debris or silt to prevent re-contamination of the engine after the engine is installed in the airframe and re-connected to airframe interface components.
- (7) Record and add the correct oil to engine per Chapter 12-10.
- (8) Install the engine in the airframe per instructions in the ***IO-390-C Engine Installation and Operation Manual***.
- (9) Complete an Operational Ground Check per Chapter 72-00 to make sure the engine is operating correctly before returning the engine to service.

E. Engine on Fire or Near a Fire

Replace any components exposed to heat from a fire.

It is recommended the engine be sent to Lycoming Engines for evaluation. Include a description that the engine was in or near a fire or external heat.

OR

Complete the following in the field in accordance with this manual

- (1) Remove, disassemble, and clean the engine (per Chapters 72-00, 72-05, and 05-30)
- (2) Complete an inspection of engine components per chapters in this manual.

NOTICE: Refer to the latest revision of Service Bulletin No. 240 which identifies certain parts that must be replaced on engine reassembly.

- (3) Assemble the engine per Chapter 72-10 and complete an Operational Ground Check per Chapter 72-00.

F. Hydraulic Lock

 WARNING: DO NOT OPERATE THE ENGINE IF HYDRAULIC LOCK IS SUSPECTED. HYDRAULIC LOCK CAN CAUSE DAMAGE TO THE ENGINE.

Hydraulic lock is caused by liquid accumulation in either the Induction System or the cylinder assembly.

- (1) The liquid prevents movement of the piston during the compression stroke.
- (2) Damage to the engine occurs when the other cylinders fire, which forces the piston in the liquid-filled cylinder through the compression stroke.
- (3) Damage to an engine from hydraulic lock can be extensive due to the high forces. These forces can damage connecting rods, pistons, cylinder assemblies, piston pins, the crankcase, and the crankshaft.
- (4) Hydraulic lock can occur as a result of any of the following:
 - Incorrect operation of the fuel drain valve adapter assembly.
 - Incorrect starting procedures.
 - Failure to remove preservative oil from an engine that had been in storage.
- (5) Either send the engine to Lycoming or an overhaul facility for evaluation. Include a description and details of the hydraulic lock.

OR

Examine the engine for hydraulic lock in the field as follows:

- (a) Remove all cylinders as per the “Cylinder Removal” procedure in Chapter 72-30.
- (b) Refer to Chapter 72-20 to remove and examine the connecting rods.
- (c) If all connecting rods are in compliance with the specified criteria in the latest revision of the *Service Table of Limits - SSP-1776*, install the connecting rods.
- (d) If any connecting rod is not in compliance with acceptance criteria, disassemble the engine to examine the crankcase and crankshaft as per Chapters 72-05 and 72-20.

G. Volcanic Ash/Particulate Contamination

⚠ CAUTION: IF VOLCANIC ASH IS SUSPECTED ON THE ENGINE, DO NOT INHALE IT OR TOUCH IT WITH BARE HANDS OR GET IT IN YOUR EYES. WEAR PERSONAL PROTECTIVE EQUIPMENT. **DO NOT USE WATER** TO RINSE IT OFF. THE VOLCANIC ASH CAN CONTAIN ACIDIC COMPOUNDS WHICH MUST NOT BE INHALED OR TOUCHED SINCE IT CAN CAUSE INJURY.

- (1) Given the dynamic conditions of volcanic ash, Lycoming recommends that engines not be operated in areas where volcanic ash is seen in the air or on the ground. Ash on the ground and runways can inadvertently get into the engine compartment and cause engine damage during landing or take-off.
- (2) If volcanic ash or particulates get into the engine oil, engine malfunction and/or failure can occur from abrasive wear.
- (3) In volcanic ash fall-out or high sand or dust areas, after the engine cools, install inlet and exhaust covers to prevent entry of airborne volcanic ash into the engine.
- (4) In the event that the engine has been in particulate-laden atmospheres, especially volcanic ash clouds or with ash on the ground, complete the standard actions in Table 2. Refer to Service Instruction No. SI-1530 for additional details.

**Table 2
Action to Take in Volcanic Ash Conditions**

Maintenance after flight...	Maintenance after 10 hours of operation or the next flight...
Wear personal protective equipment (gloves, respiratory, and eye protection). Per the aircraft manufacturer’s instructions, thoroughly remove the ash or particulate from the aircraft by hand brushing or air/vacuuming. Make sure that all ash is removed from the engine and cowling.	Wear personal protective equipment. Examine the external engine and cowling for any particulate or ash residue. Remove any particulate or ash residue per the aircraft manufacturer’s instructions.
Complete the post-flight inspection. Particularly, examine the induction filters, induction system, and engine baffles for blockage or damage.	Complete the pre-flight inspection per the Pilot’s Operating Handbook (POH).
Immediately, complete an oil change and replace the oil filter or clean the oil pressure screen. Collect an oil sample and have a spectrographic analysis done on the oil sample. Compare this analysis with past oil analyses to determine engine wear or contamination. Refer to Chapter 12-10.	Change the oil and replace the oil filter or clean the oil pressure screen. Collect an oil sample for spectrographic analysis. Compare the results against the last oil sample to identify engine wear or effects of contamination. As a precaution, complete another oil change and analysis of another oil sample again. Refer to Chapter 12-10.
Replace the intake air filter, as per the aircraft manufacturer’s instructions to remove any internal contamination that can cause premature wear because of the highly abrasive effects from most solid particles.	Replace the intake air filter as a precaution to be sure there are no effects from particulate contamination. Replace the intake air filter again after the next flight.

**Table 2 (Cont.)
Action to Take in Volcanic Ash Conditions**

Maintenance after flight...	Maintenance after 10 hours of operation or the next flight...
Examine the external condition of the engine, all accessories, external fuel and oil cooling air baffles, oil hoses, and all other components for corrosion or scoring. Identify any possible damage caused by the high speed impact from solid particles and corrosive effects caused by the chemical composition of volcanic ash.	Examine the external condition of the engine, all accessories, external fuel and oil cooling air baffles, oil hoses, and all other components for corrosion or scoring. Identify any possible damage caused by high speed impact from solid particles and corrosive effects caused by the chemical composition of the volcanic ash.
Drain all other fuel/fluids from the engine and replace with clean fluids. Replace the disposable fuel pump filter or remove and clean the fuel inlet screen, as per the aircraft manufacturer’s instructions.	Remove and examine the fuel pump filter or fuel inlet screen to identify any remnants of contamination. Replace the fuel pump filter or clean the fuel inlet screen if contamination is found.
Examine seals for damage and leaks. Replace damaged or leaky seals.	Monitor oil temperature and pressure for indications of engine problems during flight.
<p align="center">⚠ CAUTION:</p> <p>DO NOT USE HIGH PRESSURE AIR SPRAY ON THE WIRING HARNESS.</p> <p>Clean the engine with a high pressure air spray. Be sure to clean the cooling fins on the cylinders.</p>	

H. Valve Sticking

(1) The primary causes of intake or exhaust valve sticking are:

- (a) Accumulated contaminants in the oil and oil filter or oil pressure screen can collect on valve stems and/or guides to prevent valve movement and cause intermittent engine hesitation or “miss.” If the contamination deposits are not removed, the valve becomes stuck and causes engine damage.
- (b) Conditions that can increase valve sticking include:
 - High ambient temperature
 - Slow flight with reduced cooling
 - High lead content in fuel
 - Oil changes and oil filter replacement not done as frequently as necessary. Refer to the “Oil Servicing Schedule” in Chapter 12-10.
 - Induction system not sealed - unfiltered air enters engine
 - Cooling air baffles and/or baffle strip deterioration
 - Sudden cool down of the engine that can occur with a rapid descent with reduced power or engine shutdown without sufficient engine cooling.

NOTICE: If valve sticking is a problem on an IO-390-C engine, refer to the latest revisions of Service Letter No. L197, Service Bulletin No. SB-388, and Service Instruction No. SI-1425 and complete the 1000-hour inspection in Chapter 05-20. Refer to the section “Corrective Action for Valve Sticking” in Chapter 72-30.

If the 1000-hour inspection is completed before 1000 hours of operation because of valve sticking, complete the scheduled 1000-hour inspection the next 1000 from the time of this inspection unless valve sticking occurs again.

I. Oil Starvation/Sudden Loss of Oil Pressure

(1) To operate correctly at various attitudes, the engine must be supplied with a sufficient quantity of approved lubricating oil. Unless there is an adequate quantity of lubricating oil at all times during flight, loss of oil pressure can occur.

NOTICE: Refer to Appendix A of the *IO-390-C Series Engine Installation and Operation Manual* for the minimum oil quantity.

(2) Very often a sudden loss of oil pressure is quickly followed by a sudden rise in oil temperature.

(3) As a preventive measure, before every take-off, complete a check of the engine oil level as per instructions in "Oil Level Check" in Chapter 12-10. Make sure the oil level is above the minimum specified level.

NOTICE: Circumstances which cause loss of oil pressure can be different which makes prediction of the extent of damage to the engine or future engine reliability difficult. In case of oil pressure loss or engine operation with oil below the minimum operating level, the most conservative action is to remove the engine, (Chapter 72-00), disassemble (Chapter 72-05), and completely examine all engine components per chapters herein. Any decision to operate an engine that had loss of oil pressure without an inspection must be the responsibility of the agency putting the aircraft back into service.

(4) Any time oil pressure falls below the minimum level, refer to the latest revision of Service Bulletin No. SB-399, identify the root cause as per the following protocol progressive steps:

- (a) Complete the check of the oil level in the oil sump. If no oil is visible on the oil level gage (dipstick), drain the oil to measure the oil quantity.
- (b) If the oil level is sufficient, complete the check of the oil pressure indication system accuracy. If the oil pressure gage is not operating correctly, replace it.
- (c) Examine oil line connections for leaks. Tighten any loose connections per the torque values in the latest revision of the *Service Table of Limits - SSP-1776* and look for leaks. Replace leaking oil lines.
- (d) Examine the oil suction screen at the oil sump and the oil pressure screen or oil filter for blockage or metal deposits. If metal or blockage is found, remove the material and identify the origin of material and correct the root cause.

- (e) Examine the oil pump for malfunction. Replace the oil pump if it is not operating correctly. Refer to Chapter 72-25.
- (f) If the oil pressure indication system is operating correctly and there has been confirmation that oil pressure loss/oil starvation has occurred, remove the engine (Chapter 72-00) and send to Lycoming or disassemble the engine for evaluation (Chapter 72-05).

J. Propeller Strike, Sudden Engine Stoppage or Loss of a Propeller Blade Tip

Refer to the latest revision of Service Bulletin No. SB-533 for additional details.

- (1) This section includes recommendations for aircraft engines that have had propeller/rotor damage as well as any of the following.
 - Separation of the propeller/rotor blade from the hub
 - Loss of a propeller or rotor blade tip
 - Sudden stoppage
 - Any incident, whether or not the engine is operating, where repair of the propeller is necessary
 - Any incident during engine operation where the propeller has impact on a solid object. This incident includes propeller strikes against the ground. Although the propeller can continue to turn, damage to the engine can occur, possibly with progression to engine failure.
 - Sudden rpm drop on impact to water, tall grass, or similar yielding medium where propeller damage does not usually occur.
- (2) A propeller strike can occur at taxi speeds and during touch-and-go operations with propeller tip ground contact. In addition, propeller strikes also include situations where an aircraft is stationary and a landing gear collapse occurs causing one or more blades to be bent, or where a hangar door (or other object) hits the propeller blade. These instances are cases of sudden engine stoppage because of potentially severe side loading on the crankshaft propeller flange, front bearing, and seal.
- (3) Recommended Corrective Action for Propeller Strikes

⚠ CAUTION: BASED UPON THE ACCUMULATED ENGINEERING, TECHNICAL AND HISTORICAL DATA AVAILABLE, LYCOMING ENGINES **PROHIBITS** STRAIGHTENING OR GRINDING OF BENT CRANKSHAFT PROPELLER FLANGES TO RESTORE MAXIMUM RUN-OUT SPECIFICATION AS NOTED IN THE LATEST REVISION OF THE SERVICE TABLE OF LIMITS - SSP-1776. IF THE CRANKSHAFT PROPELLER FLANGE IS BENT, REPLACE THE CRANKSHAFT. **DO NOT TRY TO STRAIGHTEN OR GRIND THE CRANKSHAFT PROPELLER FLANGE.** REFER TO THE LATEST REVISION OF SERVICE BULLETIN NO. 201.
DAMAGE TO A PROPELLER IS SERIOUS AND CAN CAUSE THE ENGINE TO BE UNAIRWORTHY.

- (a) Circumstances of a propeller strike cannot always be used as predictors of the extent of engine damage or its future reliability. There can be varying degrees of damage to an engine and propeller from a propeller strike. The initial damage can be hidden but could become progressively worse with time and wear.
- (b) Given these possibilities and the fact that there is no identified clear, quantifiable threshold limit or gradient standard to reliably measure the extent of damage to an engine, Lycoming Engines can only recommend BEFORE FURTHER FLIGHT, that you complete the tasks in the sequential order shown in the Engine Inspection Checklist After Propeller Strike for IO-390-C Series Engines (in this chapter) as corrective action for a propeller strike. Make a copy of the checklist and complete it.

NOTICE: The agency that returns the aircraft to service is responsible for the decision to operate an engine that had a propeller strike. Lycoming Engines does not take responsibility for the decision to return the engine to service after a propeller strike. Refer to the latest revision of Service Bulletin No. SB-533.

Engine Inspection Checklist After Propeller Strike for IO-390-C Series Engines		
Engine Model:		Engine Serial Number:
Date Inspection Started:		Date Inspection Completed:
Sequential Task	Additional Information	Corrective Action Done/Comments
1. Examine the propeller for extent of damage; record condition of propeller.	Condition of Propeller/Corrective Action: <input type="checkbox"/> Propeller satisfactory <input type="checkbox"/> Repair propeller in accordance with propeller manufacturer's instructions <input type="checkbox"/> Replace propeller in accordance with the airframe manufacturer's instructions.	
2. Remove the propeller.	As per airframe and propeller manufacturer's instructions.	
3. Remove the engine.	Refer to Chapter 72-00	
CRANKCASE P/N:		MATCH NO:
4. Disassemble the engine - remove the crankshaft, camshaft, connecting rods, crankshaft gear, and internal steel parts.	Refer to Chapter 72-05	

Engine Inspection Checklist After Propeller Strike for IO-390-C Series Engines (Cont.)		
Sequential Task	Additional Information	Corrective Action Done/Comments
5.	Complete grit-blast cleaning* of the crankcase with 17-grit walnut shells or equivalent at 35 to 45 psi (241 to 310 kPa); remove all coatings on the crankcase and engine mount bosses.	Make sure there is no dirt, debris, sludge, paint, or any other substance that could prevent reliable Fluorescent Penetrant Inspection (FPI) or subsequent oil flow.
6.	Complete grit-blast cleaning* of the oil sump and engine mount bosses with 17-grit walnut shells or equivalent at 35 to 45 psi (241 to 310 kPa)	Make sure there is no dirt, debris, sludge, paint, or any other substance that could prevent reliable FPI or subsequent oil flow.
7.	Complete grit-blast cleaning* of the engine mount brackets (if used) with 17-grit walnut shells or equivalent at 35 to 45 psi (241 to 310 kPa).	Make sure there is no dirt, debris, sludge, paint, or any other substance that could prevent reliable FPI or subsequent oil flow.
8.	Complete grit-blast cleaning* of the accessory housing with 17-grit walnut shells or equivalent at 35 to 45 psi (241 to 310 kPa).	Make sure there is no dirt, debris, sludge, paint, or any other substance that could prevent reliable FPI or subsequent oil flow.
9.	Remove and discard the existing crankshaft gear retaining bolt and lockplate.	Refer to the “Crankshaft Disassembly” procedure in Chapter 72-20.
10.	Examine the crankshaft.	Refer to the “Crankshaft Inspection” procedure and checklist in Chapter 72-20.
11.	Examine, the crankshaft counter-bored recess, the alignment dowel especially at the base where it goes into the crankshaft, the bolt hole threads, and the crankshaft gear for wear, galling, corrosion, and fretting.	Refer to the latest revision of Service Bulletin No. 475. If the bolt hole threads are damaged, they cannot be repaired. Replace the crankshaft.
12.	Clean the crankshaft, camshaft, crankshaft gear, counterweights, rollers and bushings.	Refer to procedures and guidelines in Chapter 05-30. Make sure there is no dirt, debris, sludge, paint, or any other substance that could prevent reliable magnetic particle inspection or subsequent oil flow.
* Refer to the “Grit-Blast Procedure” in Chapter 05-30.		

Engine Inspection Checklist After Propeller Strike for IO-390-C Series Engines (Cont.)		
Sequential Task	Additional Information	Corrective Action Done/Comments
13. Clean the following internal parts made of steel: <ul style="list-style-type: none"> • Connecting Rods • Piston pins • Rocker shafts • Accessory drive gears • Magneto drive gears • Idler and oil pump shafts • Shaft gears and impellers 	Refer to Chapter 05-30.	
<p>⚠ CAUTION: BASED UPON THE ACCUMULATED ENGINEERING, TECHNICAL, AND HISTORICAL DATA AVAILABLE, LYCOMING ENGINES PROHIBITS STRAIGHTENING OR GRINDING OF BENT CRANKSHAFT PROPELLER FLANGES TO RESTORE MAXIMUM RUN-OUT SPECIFICATION PER THE LATEST REVISION OF THE SERVICE TABLE OF LIMITS SSP-1776. IF THE CRANKSHAFT PROPELLER FLANGE IS BENT, REPLACE THE CRANKSHAFT. DO NOT TRY TO STRAIGHTEN OR GRIND THE CRANKSHAFT PROPELLER FLANGE.</p>		
CRANKSHAFT P/N:		S/N:
14. Measure the flange run-out on the crankshaft.	Refer to the latest revisions of both Service Bulletin SB-240 and Part I of the <i>Service Table of Limits - SSP-1776</i> for crankshaft flange run-out tolerance. Record the crankshaft flange run-out measurement.	<input type="checkbox"/> Flange run-out within acceptable limits - use crankshaft <input type="checkbox"/> Replace crankshaft
15. Measure the main bearing run-out on the crankshaft.	Refer to the latest revision of Part I of the <i>Service Table of Limits - SSP-1776</i> for the main bearing run-out tolerance Record the main bearing run-out measurement.*	<input type="checkbox"/> Main bearing run-out within acceptable limits - use crankshaft <input type="checkbox"/> Replace crankshaft
16. Measure the polished dimensions on the main journals.	Refer to the latest revision of Part I of the <i>Service Table of Limits - SSP-1776</i> for the dimensions on the main journals Record the dimensions of the main journals.*	<input type="checkbox"/> Main journals within acceptable limits - use crankshaft <input type="checkbox"/> Replace crankshaft
17. Measure the polished dimensions on the pin journals.	Refer to the latest revision of Part I of the <i>Service Table of Limits - SSP-1776</i> for the dimensions on the pin journals Record the dimensions of the pin journals.*	<input type="checkbox"/> Pin journals within acceptable limits - use crankshaft <input type="checkbox"/> Replace crankshaft
<p>* If the measurement or dimension is out of tolerance, discard the crankshaft and replace it with a serviceable crankshaft. Install the crankshaft per "Crankshaft Installation" in Chapter 72-20.</p>		

Engine Inspection Checklist After Propeller Strike for IO-390-C Series Engines (Cont.)			
18.	Complete a check of the connecting rods parallelism.	Refer to the “Connecting Rods Parallelism/Squareness Check” in Chapter 72-20 for measurement instructions. Record the parallelism measurement for each connecting rod. Replace all connecting rods not in compliance with measurements in the latest revision of Part I of the <i>Service Table of Limits - SSP-1776</i> (Reference 503).	Parallelism Measurement
			Connecting Rod 1
			Connecting Rod 2
			Connecting Rod 3
			Connecting Rod 4
19.	Complete a check of connecting rod squareness.	Refer to the section “Connecting Rod Parallelism/Squareness Check” in Chapter 72-20. Record the squareness measurement for each connecting rod. Replace all connecting rods not in compliance with measurements in the latest revision of the <i>Service Table of Limits, SSP-1776</i> (Reference 504).	Squareness Measurement
			Connecting Rod 1
			Connecting Rod 2
			Connecting Rod 3
			Connecting Rod 4
NOTICE: The magnetic particle inspection must be done by a certified technician as per the latest revision of Service Instruction No. 1285.			
Sequential Task		Additional Information	Corrective Action Done/Comments
20.	Complete a magnetic particle inspection on the crankshaft.†	Record test results.	<input type="checkbox"/> Magnetic particle test results acceptable <input type="checkbox"/> Replace crankshaft
21.	Complete a magnetic particle inspection on the crankshaft counterweights.† Examine the counterweight bushing bores in both the counterweights and the crankshaft.	Record test results.	Replace all counterweight pins, bushings, end plates and snap rings -regardless of their condition.
22.	Complete a magnetic particle inspection on the camshaft.†	Record test results.	<input type="checkbox"/> Use camshaft <input type="checkbox"/> Replace camshaft
23.	Complete a magnetic particle inspection on the connecting rods.†	Record test results.	Replace connecting rod bolts and nuts -regardless of condition. Refer to the latest revision of Service Instruction 1458 for assembly instructions.
24.	Complete a magnetic particle inspection on the crankshaft gear.† Examine the gear end as per the latest revision of Service Bulletin No. 475.	Record test results.	<input type="checkbox"/> Use camshaft gear <input type="checkbox"/> Replace crankshaft gear
† Refer to the section “Non-Destructive Testing” in this chapter.			

Engine Inspection Checklist After Propeller Strike for IO-390-C Series Engines (Cont.)		
Sequential Task	Additional Information	Corrective Action Done/Comments
25. Complete a magnetic particle inspection† on the following internal parts made of steel: <ul style="list-style-type: none"> • Accessory drive gears • Magneto drive gears • Idler and oil pump shafts • Shaft gears and impellers • Piston pins • Connecting rods 	Record test results.	Use Replace <input type="checkbox"/> <input type="checkbox"/> Accessory drive gears <input type="checkbox"/> <input type="checkbox"/> Magneto drive gears <input type="checkbox"/> <input type="checkbox"/> Idler and oil pump shafts <input type="checkbox"/> <input type="checkbox"/> Shaft gears and impellers <input type="checkbox"/> <input type="checkbox"/> Piston pins <input type="checkbox"/> <input type="checkbox"/> Connecting Rods
† Refer to the section “Non-Destructive Testing” in this chapter.		
26. Complete the visual inspection and Fluorescent Penetrant Inspection (FPI) on the crankcase. Closely examine the forward crankcase bearing support and adjacent structure.	Record test results.	<input type="checkbox"/> Use crankcase <input type="checkbox"/> Replace crankcase
27. Complete the visual inspection and FPI on the oil sump.	Record test results.	<input type="checkbox"/> Use oil sump <input type="checkbox"/> Replace oil sump
28. Complete the visual inspection and FPI on the engine mounts.	Record test results.	<input type="checkbox"/> Use engine mounts <input type="checkbox"/> Replace engine mounts
29. Complete the visual inspection and FPI on the accessory housing.	Record test results.	<input type="checkbox"/> Use accessory housing <input type="checkbox"/> Replace accessory housing
30. Complete the visual inspection and FPI on the oil pump impeller.	Record test results.	<input type="checkbox"/> Use impeller <input type="checkbox"/> Replace impeller
31. Examine the magneto in accordance with the magneto manufacturer’s instructions.	Record test results.	<input type="checkbox"/> Use magneto <input type="checkbox"/> Replace magneto
32. Examine the pistons per instructions in Chapter 72-30.	Record test results.	<input type="checkbox"/> Pistons acceptable <input type="checkbox"/> Replace pistons
33. Refer to the latest revision of Service Bulletin No. 240 to identify any parts that must be replaced during engine assembly.	Record parts that must be replaced.	
34. Install a new crankshaft gear retaining bolt and new lockplate.	Refer to the “Crankshaft Gear Installation” procedure in Chapter 72-20.	
35. Replace all of the roller tappets with new or serviceable roller tappets.	Refer to Chapter 72-20 in this manual.	

Engine Inspection Checklist After Propeller Strike for IO-390-C Series Engines (Cont.)			
Sequential Task		Additional Information	Corrective Action Done/Comments
36.	Replace all of the counterweight rollers and counterweight bushings on the crankshaft with new counterweight rollers and bushings.	Refer to Chapter 72-20 in this manual	
37.	Review the documents of all engine-mounted accessories including the propeller governor (if installed), etc. for continued airworthiness instruction.		
38.	Assemble and install the engine. Install the propeller and test the engine. Complete an operational check of the engine.	In accordance with instructions in Chapters 72-00 and 72-10 and the latest revision of Service Instruction No. SI-1427.	
39.	Record maintenance findings and any corrective action.		
UNAIRWORTHY PARTS:			
ADDITIONAL WORK/INSPECTIONS NECESSARY:			
OUTCOME OF INSPECTION- SUMMARY NOTES:			

2. Non-Destructive Testing (Magnetic Particle Inspection and Fluorescent Penetrant Inspection.)

Refer to the latest revision of Service Instruction No. SI-1285 for additional details.

A. Non-destructive testing (NDT) that can be done on engine components include Magnetic Particle Inspection (MPI) and Fluorescent Penetrant Inspection (FPI). The purpose of the NDT is to identify the presence or potential of structural failures in an engine component.

The MPI is used for detection of discontinuities on the surface and/or sub-surface of ferromagnetic materials such as iron, nickel, cobalt, and some of their alloys.

The FPI is used to identify casting, forging and welding surface defects such as hairline cracks, surface porosity, leaks in new products, and fatigue cracks on in-service components.

B. Penetrant Materials Used for NDT

Do not use visible dye for MPIs or FPIs because visible dye penetrant materials have an adverse effect on future penetrant inspections which can cause indications to be tightly closed and therefore missed during future inspections.

C. Requirements for NDT Personnel

Personnel who complete the Magnetic Particle and Fluorescent Penetrant Inspections on Lycoming engine components must be certified to a written procedure in accordance with *NAS-410, Certification and Qualification of NDT personnel*. Also, personnel who make the "accept" or "reject" decisions during the inspections must be certified to at least Level II in accordance with NAS-410.

D. NDT Inspection Procedure Requirements and Guidelines

There must be written procedures for the Magnetic Particle Inspection and the Fluorescent Penetrant Inspection that have been approved by someone who is certified to Level III in accordance with NAS-410.

E. Before NDT, clean the components per the "Cleaning Method for Non-Destructive Testing" in Chapter 05-30.

F. Inspection Guidelines

- (1) The inspections must be done per established acceptance criteria to ensure component conformance.
- (2) A 3 power to 10 power magnifying glass must be used to evaluate indications.
- (3) If a Magnetic Particle Inspection is difficult to do on an odd-shaped part, the Fluorescent Penetrant Inspection can be used if the acceptance criteria are concerned about surface indications only.

12-10 - SERVICING - REPLENISHING

1. Refueling

⚠ CAUTION: THE CORRECT APPROVED FUEL MUST BE USED FOR THIS ENGINE. OTHERWISE ENGINE DAMAGE CAN OCCUR IF INCORRECT FUEL IS USED.

- A. Only use the approved fuel identified for your engine in the latest revision of Service Instruction No. SI-1070.
- B. Do not use any fuel that has a lower octane rating than the fuel specified for your engine.
- C. Refer to the aircraft manufacturer's manual for fuel capacity.

2. Oil Level Check

⚠ WARNING: DO NOT FLY THE AIRCRAFT IF THE OIL LEVEL IS LESS THAN THE MINIMUM OIL LEVEL. IF THE ENGINE IS OPERATED WITH AN INSUFFICIENT OIL LEVEL, ENGINE DAMAGE CAN OCCUR. REFER TO THE SECTION "OIL STARVATION/SUDDEN LOSS OF OIL PRESSURE" IN CHAPTER 05-50.

- A. The oil in the engine must be kept at the correct level for the engine to operate correctly.
- B. Measure the oil level of an engine before every flight as follows:
 - (1) Pull out the oil level gage assembly (dipstick) from the oil level gage tube (Figure 1).

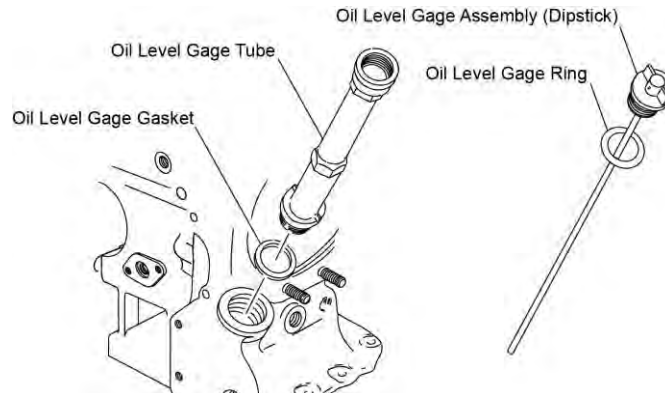


Figure 1
Oil Fill Tube and Oil Level Gage (Dipstick)

- (2) Wipe all oil from the dipstick end with a clean, lint-free cloth. Do not let any lint or dirt remain on the dipstick or get in the oil fill port.
- (3) Insert the dipstick fully back into the oil level gage tube, threaded all the way down to the oil sump and then remove the dipstick.
- (4) Look at the oil level indication on the dipstick end.

NOTICE: The approved oil, oil sump capacity, and the minimum quantity for engine operation are identified in Appendix A of the *IO-390-C Series Engine Installation and Operation Manual*.

- (5) If the oil level is not sufficient, add the correct oil through the fill port. Refer to the section "Add Oil to the Engine" in this chapter.

- C. Re-install the dipstick securely.

3. Oil Consumption

NOTICE: To ensure accurate calculation of oil consumption, each time oil is added to the engine, record the amount of oil added in the engine logbook.

- A. Use the following formula to calculate the maximum allowable oil consumption limits for this engine and record the value in the engine logbook. Compare this oil consumption value to past oil consumption values.

$$0.006 \times \text{BHP} \times 4 \div 7.4 = \text{Qt./Hr.}$$

⚠ WARNING: ONCE BREAK-IN IS COMPLETE, IF OIL CONSUMPTION IS EXCESSIVE, THE AIRCRAFT IS NOT TO BE IN FLIGHT. EXCESSIVE OIL CONSUMPTION IS AN INDICATION OF A PROBLEM, SUCH AS OIL LEAKS OR CYLINDER MALFUNCTION.

- B. If engine oil serviced is consistently high or oil consumption has increased or is excessive:
- (1) Complete the “Cylinder Borescope Inspection Procedure” in Chapter 72-30.
 - (2) Refer to Chapter 12-30 for corrective action to identify and correct the cause of the excessive oil consumption before further flight.

4. Oil Type and Viscosity

- A. The oils to be used in the IO-390-C series engines are identified in Appendix A of the ***IO-390-C Series Engine Installation and Operation Manual***.
- B. Refer to the latest revision of Service Instruction No. SI-1014 for additional details.

5. Add Oil to the Engine

NOTICE: Each time oil is added to the engine, record the quantity of oil added in the engine logbook to calculate oil consumption.

A. Oil Additives

Refer to the latest revision of Service Instruction No. SI 1409 for quantity and instructions to add the oil additive.

NOTICE: The approved oil, oil sump capacity, and the minimum quantity for engine operation are identified in Appendix A of the ***IO-390-C Series Engine Installation and Operation Manual***.

On new, rebuilt, or overhauled engines, during the first 50 hours of engine operation, operate these engines with mineral oil until oil consumption has stabilized. Afterwards, complete an oil change, drain the mineral oil and add new oil identified in Appendix A of the ***IO-390-C Series Engine Installation and Operation Manual***.

B. To add oil to the IO-390-C Series engine:

- (1) Pull out the oil level gage assembly (dipstick) (Figure 1) from the oil level gage tube.
- (2) Add either new clean mineral oil (if within the first 50 hours of operation of a new, rebuilt, or overhauled engine) or specified oil of the correct viscosity for the ambient temperature (identified in Appendix A in the ***IO-390-C Series Engine Installation and Operation Manual***) to the oil sump through the oil level gage tube.
- (3) Measure the oil level per the “Oil Level Check” procedure in this chapter. Add more oil if necessary until the oil level in the engine is sufficient.
- (4) Install the oil level gage assembly (dipstick) into the oil level gage tube securely.

6. Oil Leak Check

A. Examine the following for oil leaks:

- Oil sump drain plug
- Suction screen plug (IO-390-C engine models)
- Oil filter
- Oil hoses connected to the oil cooler

B. If leaks are found, identify and correct the cause. Complete the Operational Leak Check Sheet in Chapter 05-20.

C. After the cause of the oil leak is corrected, measure the oil level. Refer to “Oil Level Check” in this chapter. Add oil as necessary per the procedure “Add Oil to the Engine” in this chapter.

7. Oil Servicing Schedule

A. The recommended schedule for oil changes, suction screen cleaning, and oil pressure screen cleaning or oil filter replacement are shown in Table 1.

Table 1
Oil Servicing Schedule

Task	Frequency
Initial oil change and oil filter replacement or oil pressure screen cleaning of any new, rebuilt or overhauled engine, or engine returned to service after storage	After the first 25 hours of operation after initial start-up or every 4 months (whichever occurs first*) Repeat as necessary until oil consumption stabilizes.
Routine oil change and oil filter replacement (after initial 25-hour oil change and oil filter replacement) on engines with an oil filter & Oil suction screen cleaning/inspection	After every 50 hours of engine operation or every 4 months (whichever occurs first*) After replacement of any engine cylinder
Routine oil change and oil pressure screen cleaning/inspection	After every 25 hours of operation or every 4 months (whichever occurs first*) After replacement of any engine cylinder
* Oil change intervals must not exceed 4 months regardless of operating hours and especially if the aircraft has not been flown for at least 25 hours in a 4-month period. More frequent oil changes are recommended if the engine has been exposed to volcanic ash, particulate, sand, dust, debris, or extreme weather conditions.	

8. Oil Change Procedure

NOTICE: Refer to Table 1 for the oil servicing schedule for your engine.

An anti-scuffing oil additive can be added to the oil sump during an oil change. Refer to the latest revision of Service Instruction No. SI-1409 for oil additive information.

On new, rebuilt, or overhauled engines, during the first 50 hours of engine operation, operate this engine on mineral oil until oil consumption has stabilized.

A. Operate the engine until the oil temperature stabilizes and then shut down the engine.

NOTICE: Within 30 minutes after engine shutdown, complete the oil change and collect an oil sample from the oil sump. Follow the oil sample collection procedures of the laboratory where the oil sample is to be sent.

B. Wait at least 15 minutes after engine shutdown and then proceed with the oil change.

C. Drain the oil from the oil sump as follows:

- (1) Put a suitable collection container with a minimum 15-quart (14-liter) capacity under the drain plug of the oil sump (Figure 2).
- (2) Remove and discard the safety wire or safety cable from the oil drain plug.
- (3) Remove the oil drain plug from the oil sump.
- (4) Connect an oil drain hose if available.
- (5) For routine oil changes, collect an oil sample per the laboratory vendor's sample oil collection procedure.
- (6) Let the remainder of the oil drain from the engine into the collection container.

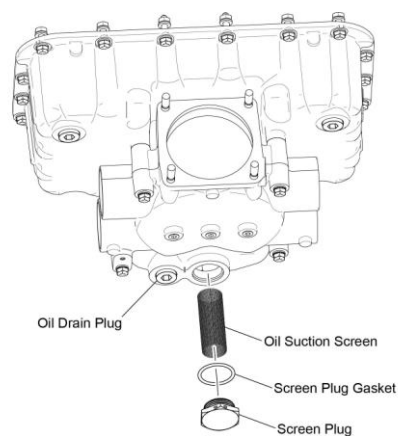


Figure 2
Oil Suction Screen and Drain Plug

D. Apply one to two drops of Loctite[®] 564[™] or equivalent to the threads of the oil sump drain plug and install the oil sump drain plug in the oil sump. Torque the drain plug in accordance with the Standard Torque Tables in the latest revision of the *Service Table of Limits - SSP-1776*.

CAUTION: MAKE SURE THAT THE OIL SUMP DRAIN PLUG IS INSTALLED TIGHTLY. IF THE DRAIN PLUG IS NOT TIGHTLY INSTALLED AND LEAKS, ENGINE FAILURE CAN OCCUR.

E. Send the oil sample in the vial to the same laboratory (that has been used in the past) for spectrographical analysis to compare past results and identify a wear trend pattern. Refer to the latest revision of Service Letter L171 for spectrographic oil analysis.

F. If the engine has an oil pressure screen, complete the "Oil Pressure Screen Removal/ Inspection/Cleaning/ Installation" procedure in this chapter.

OR

If the engine is equipped with an oil filter, complete the "Oil Filter Replacement" procedure in this chapter during the oil change.

G. Complete the "Oil Suction Screen Removal/Inspection/Cleaning/Installation" procedure in this chapter.

- H. Add oil of the correct viscosity for ambient temperature to the engine. Refer to the "Add Oil to the Engine" procedure in this chapter.
 - I. If an oil line has been disconnected or if the oil cooler was drained or replaced or after any prolonged period of engine inactivity, complete the "Engine Pre-Oil Procedure" in this chapter.
 - J. Complete the "Oil Level Check" procedure in this chapter.
 - K. Safety cable/wire the oil sump drain plug, suction screen plug, and oil filter (if applicable) in accordance with the standard practices per the latest revision of AC43.13-1B or the latest revision of Service Instruction No. SI-1566.
 - L. Dispose of the oil in the collection container in accordance with environmental safety laws.
 - M. Wipe away any oil spilled on the engine.
9. Engine Pre-Oil Procedure

Refer to the latest revision of Service Instruction No. SI-1241 for additional details.

Complete the engine pre-oil procedure on the engine at the following times:

- Before the initial start of an engine after engine installation
- After oil cooler replacement or draining
- After disconnecting any oil lines from the oil cooler circuit.
- After any prolonged period of inactivity requiring a preservation procedure per the latest revision of Service Letter No. L180

To complete the pre-oil procedure:

- A. If not already done, fill the oil sump with clean engine oil to the correct level per the "Add Oil to the Engine" procedure in this chapter.
- B. Make sure that the Ignition switch, the Auxiliary Fuel Pump switch, and the Fuel Selector are all in the OFF position.
- C. Fill the oil cooler with engine oil per the airframe manufacturer's instructions.
- D. Disconnect the ignition leads from all spark plugs.
- E. Per the "Spark Plug Removal" procedure in Chapter 74-20, remove one spark plug from each cylinder of the engine. Remove and discard the spark plug gasket.
- F. Move the throttle control to the FULL OPEN position.

⚠ CAUTION: DO NOT ENERGIZE THE STARTER FOR PERIODS OVER 10 TO 15 SECONDS. LET THE STARTER COOL FOR 30 SECONDS AFTER EACH ENERGIZATION. IF THE STARTER FAILS TO ENERGIZE AFTER TWO ATTEMPTS, IDENTIFY AND CORRECT THE CAUSE PER THE AIRFRAME MANUFACTURER'S MAINTENANCE MANUAL.

- G. Pre-oil start cycle: Energize the starter for 10 to 15 seconds and look for evidence of oil pressure of at least 20 psi (138 kPa) within 10 to 15 seconds.
If there is no oil pressure within 10 to 15 seconds, stop energizing the starter. Wait at least 30 seconds and repeat the pre-oil start cycle.

Up to six consecutive pre-oil start cycles can be done. Afterwards let the starter cool for 30 minutes. If stable oil pressure is not achieved, stop pre-oiling and contact Lycoming Engines.

NOTICE: Unstable oil pressure or oil pressure less than 20 psi (138 kPa) could be an indication of obstructed or interrupted oil flow or air in the oil lines.

H. If oil pressure of at least 20 psi (138 kPa) was sustained in the previous step, repeat the pre-oil start cycle to make sure oil pressure holds stable and that there is not a sudden drop in oil pressure. If oil pressure is not stable or drops suddenly, stop pre-oiling and contact Lycoming Engines.

NOTICE: Install a new spark plug gasket whether a new or acceptable re-used spark plug is to be installed.

I. Once the minimum oil pressure of 20 psi (138 kPa) is shown on the oil pressure gage, re-install the spark plugs each with a new gasket as per the "Spark Plug Installation" procedure in Chapter 74-20.

J. Reconnect the ignition leads to all spark plugs.

K. Within the next 3 hours start and operate the engine for 3 minutes at approximately 1000 rpm. Refer to the "Engine Start and Operation" chapter in the *IO-390-C Series Engine Installation and Operation Manual*.

10. Oil Suction Screen Removal/Inspection/Cleaning/Installation

NOTICE: On the IO-390-C (Figure 2) engines there is an oil suction screen in the oil sump.

A. Remove and discard the safety wire/cable from the oil drain plug and the screen plug on the oil sump (Figure 2).

B. Put a suitable collection container with a minimum 15-quart (14-liter) capacity under the drain plug of the oil sump.

C. Remove the oil sump drain plug and drain the oil from the engine.

D. Remove the screen plug and oil suction screen from the oil sump.

E. Remove and discard the gasket from the screen plug.

F. Before cleaning the oil suction screen.

(1) Examine the oil suction screen for distortion, deformation or openings in the mesh and/or metallic particles, shavings, or flakes (which can be an indication of possible excessive internal wear on the engine).

(2) Examine any material trapped in the oil suction screen. Examine the condition of the oil and particles on the oil suction screen. Look for shining, metallic residue which is an indication of a high concentration of metal.

NOTICE: Results from examination of the oil suction screen on the first oil change of a new, rebuilt or overhauled engine usually will show small metallic particles or shavings which are acceptable.

(3) If steel, copper or aluminum particles are found on the oil suction screen, examine the cylinders and other metal components for wear or damage.

G. Clean the oil suction screen with mineral spirits or equivalent degreasing solvent.

H. Apply Food Grade Anti-Seize to the threads of the screen plug and install the oil suction screen (do not flare the ends of the suction screen) in the oil sump with a new gasket, and the screen plug.

- I. Tighten the screen plug until the sealing surfaces are in contact and then tighten the screen plug an additional 135°.
- ⚠ **CAUTION:** MAKE SURE THAT THE SCREEN PLUG IS INSTALLED TIGHTLY. IF THE SCREEN PLUG IS NOT TIGHTLY INSTALLED AND LEAKS, ENGINE FAILURE CAN OCCUR.
- J. Apply one to two drops of Loctite® 564™ or equivalent to the threads of the oil sump drain plug and install the oil sump drain plug in the oil sump. Torque the drain plug in accordance with the latest revision of the *Service Table of Limits - SSP-1776*.
- ⚠ **CAUTION:** MAKE SURE THAT THE OIL SUMP DRAIN PLUG IS INSTALLED TIGHTLY. IF THE DRAIN PLUG IS NOT TIGHTLY INSTALLED AND LEAKS, ENGINE FAILURE CAN OCCUR.
- K. Safety cable/wire the oil sump drain plug and the screen plug in the oil suction screen in accordance with the standard practices per the latest revision of AC43.13-1B or the latest revision of Service Instruction No. SI-1566.
- L. Add oil per the "Add Oil to the Engine" procedure in this chapter.
- M. After all service is complete, operate the engine and look for oil leaks. Identify and correct the cause of any oil leak.

11. Oil Pressure Screen
Removal/Inspection/Cleaning/Installation

NOTICE: Complete this procedure after every 25 hours of engine operation.

- A. Drain the oil from the oil sump per “Oil Change Procedure” in this chapter.
- B. Remove the four bolts, lock washers, and washers from the oil pressure screen housing (Figure 3). Discard the lock washers.
- C. Remove the oil pressure screen housing.
- D. Remove the oil pressure screen and gasket. Discard the gasket.
- E. Before cleaning, examine the oil pressure screen for distortion, deformation or openings in the mesh and/or metallic particles (which is an indication of possible excessive internal wear on the engine).
- F. If steel, copper or aluminum particles are found on the oil pressure screen, examine the cylinders and other metal components for wear or damage.
- G. Examine and keep any material trapped in the oil pressure screen. Examine the condition of the oil and particles on the oil pressure screen. Look for shining, metallic residue. Refer to the section “Engine Wear and Oil Analysis” in this chapter.

NOTICE: Results from examination of the oil pressure screen on the first oil change of a new, rebuilt or newly overhauled engine usually will show small metallic particles shavings which are acceptable.

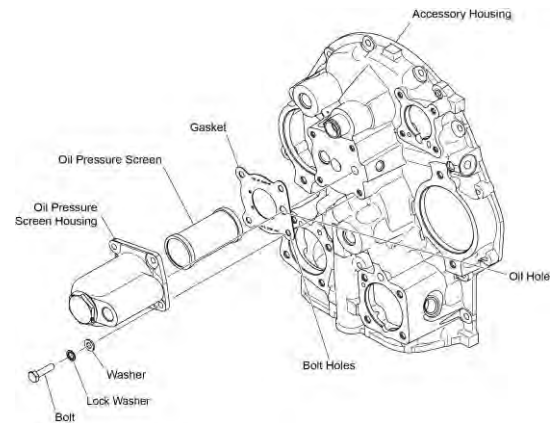


Figure 3
Oil Pressure Screen

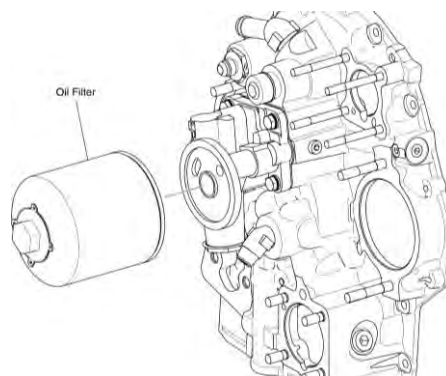
- H. Clean the oil pressure screen with mineral spirits or equivalent degreasing solvent.
- I. Examine the new gaskets for rips, damage, deformities, cracks or brittleness. Replace any cracked, brittle, deformed, torn or damaged gasket with a new gasket.
- J. Install the oil pressure screen (Figure 3) with a new gasket in the oil pressure screen housing flush with the base of the oil pressure screen housing.
- K. Install the oil pressure screen housing assembly with the new gasket on the pad of the accessory housing aligned with the bolt holes and oil hole on the pad of the accessory housing using the four bolts, each with a washer and a new lock washer as shown in Figure 3.
- L. Torque the four bolts to 96 in.-lb (11 Nm).
- M. After all service is complete, operate the engine and look for oil leaks. Identify and correct the cause of any oil leak.
- N. Add oil per the "Add Oil to the Engine" procedure in this chapter.

12. Oil Filter Replacement

NOTICE: If oil consumption is not stabilized after the initial 25-hour oil change, complete the oil change and oil filter replacement again.

After the initial 25-hour oil filter replacement and oil change, if oil consumption is stabilized, replace the oil filter after every 50 hours of engine operation during an oil change, unless otherwise directed.

- A. Drain the oil from the oil sump per “Oil Change Procedure” in this chapter.
- B. Remove the safety wire/cable (Figure 5) from the oil filter. Discard the safety wire/cable.
- C. Remove the oil filter (Figure 4) from the engine.
- D. Remove the oil filter element from the oil filter and examine the oil filter element for metal particles, shavings or flakes. Refer to the “Oil Filter Inspection” procedure in this chapter.
- E. Apply Dow Corning® 4 or engine oil to the oil filter gasket.
- F. Install the oil filter on the oil filter base as shown in Figure 4.
- G. Torque the oil filter to 17 ft.-lb (23 Nm) or per the oil filter manufacturer's instructions.
- H. Install new safety wire/cable on the oil filter (Figure 5) to keep it securely in place per the latest revision of Service Instruction No. SI-1566.



**Figure 4
Oil Filter**



**Figure 5
Safety Wire on Oil Filter**

13. Oil Filter Inspection

- A. Cut open the removed oil filter element with an approved tool (e.g., for full-flow, spin-on filters, use Champion Tool CT-470 or Airwolf Cutter AFC-470 or equivalent) per the tool manufacturer's instructions.
- B. Examine the oil filter element for metal particles, shavings or flakes.

⚠ CAUTION: IF STEEL, COPPER OR ALUMINUM PARTICLES ARE FOUND IN THE OIL FILTER. REFER TO THE LATEST REVISION OF SERVICE INSTRUCTION NO. SI-1492 FOR INSTRUCTIONS

- C. Examine the condition of the oil and particles on the filter. Look for shining, metallic residue. Refer to the section "Engine Wear and Oil Analysis" in this chapter.

14. Engine Wear and Oil Analysis

NOTICE: Refer to the latest revision of Service Letter No. L171 for additional details on Spectrometric oil analysis.

- A. Typically, the small metallic particles shavings on the oil filter element or oil pressure screen, and oil suction screen on the first oil change of an engine are acceptable. The first oil analysis also will most likely show a higher metal content. After an initial break-in period, metal content is likely to decrease rapidly to a level that remains essentially constant.
- B. However, on subsequent oil changes, an increased quantity of minute particles of metal in the oil can be evidence of engine part wear. This wear can increase over a period of time until premature failure occurs.
- C. A change in the usual wear rate of a part is not necessarily an indication of imminent failure. It is an indication that a borescope examination, cylinder compression pressure check, etc. per procedures in Chapter 72-30 are necessary to identify the cause for unusual wear. Through oil analysis for metal content, the metallic concentrations can be identified and corrective action taken.

NOTICE: If the engine has been operated in dust, sand storms, volcanic ash, wildfires, etc. more particulates could be found.

Contact Lycoming Engines' Technical Support at the phone numbers at the front of this manual, if:

- The cause of the metal contamination cannot be found
- If the next two oil analyses show progressive increases in aluminum or iron content, examine the engine cylinders per Chapter 72-30.

This page intentionally left blank.

12-30 - FAULT ISOLATION

1. Recommended Approach to Fault Isolation
 - A. Refer to the Fault Isolation Guide in Table 1.
 - B. Visually examine the engine for indications of obvious problems, such as intake and exhaust valve leaks, physical damage to ignition wires and ignition harness, blocked breathers, fuel and oil stains, etc.
 - C. Review maintenance logs to identify any trends or possible causes.
 - D. Discuss any operational problems with the pilot to identify background, details or incidents of unusual operation.
 - E. Record all findings and corrective action.
2. Fault Isolation Guide
 - A. The Fault Isolation Guide in Table 1 shows the more common and recurring problems, causes, and corrective actions. Continue from the simplest to the most complex possible causes.
 - B. The "Ref." column in Table 1 contains references to the following:
 - (1) A numeric entry such as "72-00" refers to a chapter in this manual.
 - (2) IOM refers to the *IO-390-C Series Engine Installation and Operation Manual*.
 - (3) AMM refers to the *Airframe Manufacturer's Manual*.
 - (4) POH refer to the *Pilot's Operating Handbook*.

Table 1
Fault Isolation Guide

Problem	Cause	Corrective Action	Ref.
Engine will not start or starts with difficulty	Incorrect starting procedure	Obey starting procedures or the Pilot's Operating Handbook.	IOM POH
	Throttle valve open too far	Set the throttle control approximately 1/4 (of the length of throttle control travel) open for about 800 rpm.	AMM
	Discharged battery	Replace with a charged battery.	AMM
	Faulty starter	Complete the "Starter Replacement" procedure.	72-70
	No fuel or low fuel level	Complete a check of the fuel supply. Service as required.	AMM
	No fuel flow Blockage in fuel line	<ol style="list-style-type: none"> 1. Disconnect the fuel line. 2. Complete a check of the fuel flow. 3. Examine for evidence of leaks and correct as required. 4. Clean the filters, strainers, lines, or fuel valves. 	73-10

**Table 1 (Cont.)
Fault Isolation Guide**

Problem	Cause	Corrective Action	Ref.
Engine will not start or starts with difficulty (Cont.)	Fault in the ignition system	<ol style="list-style-type: none"> 1. Visually examine the harness for physical damage. 2. Examine leads using a high-tension lead tester. 3. Replace worn or damaged components as necessary. 4. Complete the following procedures: <ul style="list-style-type: none"> • Spark Plug Removal • Ignition Harness Inspection • Spark Plug Inspection • Spark Plug Cleaning • Spark Plug Gap Setting • Spark Plug Rotation • Spark Plug Installation 	74-20 05-30
	Damaged or worn ignition lead	<ul style="list-style-type: none"> Ignition Harness Removal Ignition Harness Inspection Ignition Harness Installation 	74-20
	Magneto incorrectly timed to engine.	Complete the “Magneto-to-Engine Timing Check.”	74-30
	Magneto internal timing not adjusted correctly or "E" gap drifting because of point or follower wear.	Replace magneto with a serviceable unit as per the “Magneto Replacement Procedure.”	74-30
	Water in fuel system	Drain the fuel lines.	AMM
Rough Idle	Fault in the ignition system	<ol style="list-style-type: none"> 1. Visually examine the harness for physical damage. 2. Examine leads using a high-tension lead tester. 3. Replace worn or damaged components as necessary. 4. Complete the following procedures: <ul style="list-style-type: none"> • Spark Plug Removal • Ignition Harness Inspection • Spark Plug Inspection • Spark Plug Cleaning • Spark Plug Gap Setting • Spark Plug Rotation • Spark Plug Installation 	74-20 05-30

**Table 1 (Cont.)
Fault Isolation Guide**

Problem	Cause	Corrective Action	Ref.
Rough Idle (Cont.)	Low cylinder compression	<ol style="list-style-type: none"> 1. Complete the "Cylinder Compression Check Procedure." 2. Complete a "Borescope Inspection Procedure" on low-pressure cylinder(s). 	72-30
	Blocked injection nozzles	<ol style="list-style-type: none"> 1. Identify whether the cylinder with the suspected blocked injection nozzle is cold or hot. (The cylinder will be cold after 2 minutes of engine operation.) 2. Complete the "Injection Nozzle Fuel Flow Check." 3. Complete the "Injection Nozzle Removal" procedure. 4. Complete the "Injection Nozzle Cleaning" procedure. 5. Complete the "Injection Nozzle Installation" procedure. 	73-10 05-30 73-10
	Leak in induction system	Complete the "Induction System Inspection" procedure.	72-80
	Internal fuel injector leak	Complete the "Fuel Injector Leak Check" procedure.	73-10
	Cracked engine mounts or defective mount bushings	Replace engine mounts or bushings.	AMM
	Engine mount bushing incorrectly installed	Install the engine mount bushing correctly.	AMM
	Loose ignition lead(s)	Make sure all ignition leads are secure.	
	Lean idle mixture	<ol style="list-style-type: none"> 1. Adjust the idle mixture the "Idle Speed and Mixture Adjustment" procedure. 2. Readjust the idle speed. 	72-00

**Table 1 (Cont.)
Fault Isolation Guide**

Problem	Cause	Corrective Action	Ref.
Rough Idle (Cont.)	Low fuel pressure	<ol style="list-style-type: none"> 1. Examine the fuel filter for blockage. Clean a blocked fuel filter as per the aircraft manufacturer's instructions. 2. Replace the fuel pump as per the "Fuel Pump Replacement" procedure.* 	73-10
	Valve sticking in fuel manifold	<ol style="list-style-type: none"> 1. Complete the "Fuel Manifold Removal" procedure. 2. Send to either Lycoming Engines or an authorized overhaul facility for evaluation. 3. Complete the "Fuel Manifold Installation" procedure. 	73-10
Engine will not idle unless the boost pump is on	Lean idle mixture	<ol style="list-style-type: none"> 1. Enrich the idle mixture as per the section "Idle Speed and Mixture Adjustment." 2. Readjust the idle speed. 	72-00
	Fuel pressure too low at idle speed (engine could also lose fuel pressure as the aircraft climbs)	<ol style="list-style-type: none"> 1. Look for loose fuel line fitting. Torque any loose fuel line fitting as per the latest revision in the <i>Service Table of Limits - SSP-1776</i>. 2. Make sure the fuel pump is operating properly. 	73-10
	Idle mixture is extremely rich (evident by excess black exhaust)	<ol style="list-style-type: none"> 1. Lean the idle mixture per "Idle Speed and Mixture Adjustment" procedure. 2. Readjust the idle speed. 	72-00
	Fuel vaporizing in lines	<ol style="list-style-type: none"> 1. Operate with cowl flaps in the FULL OPEN position and keep ground operation to a minimum. 2. Operate with boost pump ON as necessary. 	

* Review any applicable warranty information relative to replacement of a fuel component as per the latest revision of Service Letters L221 and L253.

**Table 1 (Cont.)
Fault Isolation Guide**

Problem	Cause	Corrective Action	Ref.
High fuel flow	Blocked injection nozzles evident by high flow reading on pressure type fuel flow indicator	1. Complete an “Injection Nozzle Fuel Flow-Check.” 2. Complete the “Injection Nozzle Removal” procedure. 3. Complete the “Injection Nozzle Cleaning” procedure. 4. Complete the “Injection Nozzle Installation” procedure.	73-10 5-30 73-10
	Broken flow gage	Install the master fuel flow gage and operate the engine to compare gages. or Replace the non-conforming fuel flow gage.	
	Fuel injector rich	Remove the fuel injector. Either send it to a manufacturer-approved repair facility or replace it as per the “Fuel Injector Replacement” procedure.*	73-10
Low fuel flow	Dirty fuel pump filter	Remove and clean the fuel pump filter with acetone or MEK, blow out with compressed air, and re-install the fuel pump filter or Replace the fuel pump filter.	AMM
	Faulty fuel flow gage	1. Install the master fuel flow gage and operate the engine to compare gages. 2. Replace a damaged fuel flow gage.	AMM
	Fuel manifold does not open all the way at times.	1. Complete the “Fuel Manifold Removal” procedure.* 2. Send to Lycoming Engines or an authorized repair facility. 3. Complete the “Fuel Manifold Installation” procedure.	73-10
* Review any applicable warranty information relative to replacement of a fuel component as per the latest revision of Service Letters L221 and L253.			

**Table 1 (Cont.)
Fault Isolation Guide**

Problem	Cause	Corrective Action	Ref.
Low fuel flow (Cont.)	Fuel line to fuel flow gage is broken, loose, or blocked	Look for fuel dye stains to identify leaky, cracked, damaged or loose fuel lines. Replace any cracked or damaged fuel line. Refer to the “Fuel Line Replacement” procedure. To identify a blocked fuel line, disconnect the line at both ends and blow it out with compressed air. Reconnect the fuel line. Torque as per the latest revision of the <i>Service Table of Limits SSP-1776</i> . Make sure the fuel line is no longer blocked.	73-10
	Low fuel pressure	1. Examine the fuel filter for plugs; replace a plugged fuel filter as per the aircraft manufacturer’s instructions. 2. Adjust the fuel pressure in accordance with the aircraft manufacturer’s instructions. 3. Replace the fuel pump* or fuel pressure regulator. Refer to the “Fuel Pump Replacement” procedure.	AMM 73-10
Engine will not turn static rpm or will not develop rated rpm	Decreased air flow in the induction system	1. Make sure that the air filters are clean. 2. Complete the “Induction System Inspection” and remove all blockages. 3. Make sure that the air box is installed in accordance with the airframe manufacturer's specifications. 4. Repair or replace the air inlet or manifold if necessary.	72-80
	Blockage in air inlet or manifold		AMM
	Air filter dirty	Replace the air filter. NOTICE: Occasionally new air filters will have an excessive air drop through them. If this condition is suspected, remove the air filter and operate the engine to full power on a hard surface in a dust-free area.	AMM

* Review any applicable warranty information relative to replacement of a fuel component as per the latest revision of Service Letters L221 and L253.

**Table 1 (Cont.)
Fault Isolation Guide**

Problem	Cause	Corrective Action	Ref.
Engine will not turn static rpm or will not develop rated rpm (Cont.)	Too much air dropped through a new air filter Defective air filter	<ol style="list-style-type: none"> 1. Put the aircraft in a dust-free area. 2. Remove the air filter. 3. Operate the engine to full throttle. 4. If the engine operates at full rpm, replace the air filter with a new air filter. 	AMM
	Propeller is out of adjustment (not reaching low pitch)	Adjust the propeller in accordance with airframe or propeller manufacturer's instructions.	AMM
	Fouled spark plugs	<ul style="list-style-type: none"> • Spark Plug Removal • Spark Plug Cleaning • Spark Plug Fouling • Spark Plug Gap Setting • Spark Plug Rotation • Spark Plug Installation 	74-20 & 05-30
	Incorrect fuel flow	<ol style="list-style-type: none"> 1. Look for blocked fuel lines to the engine. 2. Remove the fuel injector inlet screen and flush out with acetone or MEK. Blow out with compressed air. 3. Disconnect the fuel flow gage and install a master fuel flow gage to make sure the aircraft fuel flow gage is accurate. 4. Replace the fuel injector* as necessary. Refer to the "Fuel Injector Replacement" procedure. 	73-10
	Incorrect type of fuel	Refer to the section "Incorrect Fuel or Fuel Contamination."	05-50
	Throttle lever is incorrectly adjusted	Adjust the throttle lever in accordance with airframe manufacturer's instructions.	
	Insufficient combustion	<ol style="list-style-type: none"> 1. Complete a "Cylinder Compression Check Procedure." 2. Complete a "Borescope Inspection Procedure" to look for excessive wear on the cylinders or damaged valve and valve seats. 	72-30

**Table 1 (Cont.)
Fault Isolation Guide**

Problem	Cause	Corrective Action	Ref.
Engine will not turn static rpm or will not develop rated rpm (Cont.)	Incorrect magneto-to-engine timing	Complete the "Magneto-to-Engine Timing Check."	74-30
	Incorrect internal engine timing	Complete a check of the internal engine timing and adjust as necessary	72-20
	Fuel injector clogged	Replace the clogged fuel injector* per the "Fuel Injector Replacement" procedure.	73-10
	Blockage in manifold system	Clear all ducting.	
	Leak in engine intake or exhaust	Tighten loose connections or replace manifold gaskets as necessary.	
Engine hesitates, misses	Fault in the ignition system	<ol style="list-style-type: none"> 1. Visually examine the harness for physical damage. 2. Examine leads using a high-tension lead tester. 3. Replace worn or damaged components as necessary. 4. Complete the following procedures: <ul style="list-style-type: none"> • Spark Plug Removal • Ignition Harness Inspection • Spark Plug Inspection • Spark Plug Cleaning • Spark Plug Gap Setting • Spark Plug Rotation • Spark Plug Installation 	74-20 05-30
	Valve sticking	Refer to "Corrective Action for Valve Sticking."	72-30
Engine surges	Injection nozzles are dirty	Complete the "Injection Nozzle Cleaning" procedure.	05-30
	Fuel injector malfunction	Replace the fuel injector* per the "Fuel Injector Replacement" procedure.	73-10
	Low engine oil level	Complete a check of the oil level. Add oil. Refer to the sections "Oil Level Check" and "Add Oil to the Engine."	12-10
	Malfunctioning propeller governor	Replace the propeller governor.	AMM

* Review any applicable warranty information relative to replacement of a fuel component as per the latest revision of Service Letters L221 and L253.

**Table 1 (Cont.)
Fault Isolation Guide**

Problem	Cause	Corrective Action	Ref.	
Engine surges (Cont.)	Breather is blocked	Examine the breather for obstructions. Remove all obstructions.		
	Faulty oil pump	Replace the oil pump.	72-25	
	Propeller blades are intermittently sticking in hub	Remove and overhaul the propeller as per the propeller manufacturer's instructions.		
	Front main bearing has too much clearance	Complete a "Propeller Oil Control Leak Test."	72-20	
Irregular oil pressure	Oil pump is sucking air	Replace the oil pump per the "Oil Pump Removal" and "Oil Pump Installation" procedures..	72-25	
Low oil pressure	Oil not of the correct viscosity for ambient temperature	Make sure oil of the correct viscosity for the ambient temperature is used. Refer to the latest revision of Service Instruction No. SI-1014.		
	Low engine oil level	Complete the "Oil Level Check" procedure.	12-10	
	High oil temperature	Examine the engine for these conditions: 1. Low oil level ----- 2. Incorrect grade/weight of oil Refer to the latest revision of Service Instruction No. SI-1014. ----- 3. Thermostatic oil cooler bypass valve seating and operation ----- 4. Partial or full blockage in oil cooler lines 5. High cylinder head temperature 6. Excess blow-by 7. Blockage in air duct to the oil cooler 8. Non-conforming temperature gage.		12-10
				72-50
				AMM
Pressure relief valve is out of adjustment	Turn the adjusting screw (on the oil pressure relief valve) to adjust oil pressure or change the spring as necessary		72-50	

**Table 1 (Cont.)
Fault Isolation Guide**

Problem	Cause	Corrective Action	Ref.
Low oil pressure (Cont.)	Dirt or metal chips under the oil pressure relief valve	1. Remove, disassemble, and clean (remove dirt or metal chips) the oil pressure relief valve.	72-50
		2. Complete the "Oil Change Procedure."	12-10
		3. Complete a cylinder compression check.	72-30
	Blockage at inlet side of oil pump	Remove and clean the oil suction screen and oil passage on the inlet side of the oil pump. Refer to the section "Oil Suction Screen Removal/ Inspection/Cleaning/ Installation."	12-10
	Damaged oil pressure relief valve seat	Replace the oil pressure relief valve seat per the latest revision of Service Instruction No. SI-1172.	
	Excess internal oil leakage	Look for: <ul style="list-style-type: none"> • Loose or missing plugs in oil galley • Piston cooling nozzles to lock open during idle rpm • Too much bearing clearance • Cracks in the oil galley area of the crankcase 	
Air leak on suction side		1. Examine the conditions of these components: <ul style="list-style-type: none"> • Oil suction screen gasket 	12-10
		<ul style="list-style-type: none"> • Oil sump gasket 	72-50
		<ul style="list-style-type: none"> • Oil pump mating surface to accessory housing 	72-25
Relocated oil pressure take-off		2. Replace cracked or damaged parts.	
	Relocated oil pressure take-off	Use only the approved oil pressure take-off point.	

**Table 1 (Cont.)
Fault Isolation Guide**

Problem	Cause	Corrective Action	Ref.
Low oil pressure (Cont.)	Failed or failing bearings NOTICE: Metal in the oil filter element or oil suction screen is a sign of excessive bearing wear.	Drain the oil from the oil sump. Open the crankcase and examine the bearings. Refer to “Tappet, Main Bearing, and O-Ring Removal” or It is recommended the engine be sent to Lycoming Engines for evaluation. Include a description of the problem.	12-10 72-05 72-20
	Oil pump not operating correctly	Remove and examine the oil pump.	72-25
	Oil pressure gage not operating correctly	Test the oil pressure gage.	AMM
Excessive oil consumption	New piston rings are not completely seated (break-in not done).	As part of break-in, operate the engine at not less than 65% power for the first 50 hours.	IOM
	Piston rings are worn, broken, or incorrectly installed OR Cylinder barrels are glazed or worn too much	1. Complete the “Cylinder Compression Check Procedure.” 2. Complete the “Cylinder Borescope Inspection Procedure” to determine if further corrective action is necessary NOTICE: Listen for a hissing sound at the breather of the crankcase which is an indication of air leaks around the rings.	72-30
		3. Remove the cylinders, hone the cylinder barrels, replace the piston rings, and re-install the cylinders as per the following sections: <ul style="list-style-type: none"> • Cylinder Removal • Piston Removal • Piston Inspection • Piston Ring Replacement • Barrel Glaze and Varnish Removal from Interior Cylinder Barrel • Piston Installation • Cylinder Installation 	72-30

**Table 1 (Cont.)
Fault Isolation Guide**

Problem	Cause	Corrective Action	Ref.
Excessive oil consumption (Cont.)	Worn valve guides	1. Measure the valve guides for wear as per instructions in the section “Exhaust Valve and Guide Inspection.” 2. Replace worn valve guides.	72-30
	Oil leaks	Examine the external area of the engine for leaks, identify and correct the cause of any leak.	
	Oil siphoned from engine during flight	1. Verify that the oil filler cap is secure and has either safety wire or cable, and the oil access door closes correctly. 2. Make sure that the breather tube is accurately cut and the crankcase ventilation system is installed correctly per the airframe manufacturer’s instructions.	12-10
	Oil level too high	Do not fill above the maximum oil sump capacity. ----- Drain some oil (start of “Oil Change Procedure.”)	IOM Appendix A 12-10
High oil temperature	Cooling baffles are missing, broken, or incorrectly installed	Ensure that all baffles are installed correctly and none are broken. Replace as necessary. NOTICE: Never modify, relocate, or eliminate any cooling baffles.	
	Oil level is too low	Complete the “Oil Level Check” at regular intervals. Keep oil at the specified level.	12-10
	Incorrect grade of oil	Use the correct grade of oil per the latest revision of Service Instruction No. SI-1014..	
	Thermostatic oil cooler bypass valve is not operating correctly or seating accurately	Replace the thermostatic oil cooler bypass valve.	72-50 SI-1316
	Leaks in engine induction system	Identify and correct the cause of all leaks.	72-80 & AMM

**Table 1 (Cont.)
Fault Isolation Guide**

Problem	Cause	Corrective Action	Ref.
High oil temperature (Cont.)	Oil cooler or oil cooler lines are fully or partially blocked	<ol style="list-style-type: none"> 1. Remove the oil cooler and oil cooler lines. 2. Clean and service the oil cooler. 	AMM
	Too much cylinder blow-by	Complete a “Cylinder Compression Check Procedure.”	72-30
	Defective oil temperature gage	<ol style="list-style-type: none"> 1. Install the master temperature gage and operate the engine to compare gages. 2. Replace the faulty gage if necessary. 	AMM
High manifold pressure at idle	Air leak in induction system	<p>Examine the induction system for leaks. Identify and correct the cause of all leaks.</p> <p>NOTICE: If the induction system has leaks, the engine will idle rough.</p>	72-80 & AMM
	Incorrect tappets or hydraulic lifters were installed	<p>Replace hydraulic lifters with the correct part number for lifters. Refer to the latest revision of Service Instruction Nos. 1529, 1011, and 1514.</p> <p>NOTICE: Keep the cylinders and plungers together as an assembly when you remove hydraulic lifters from the engine. If they become separated, replace with new ones. Incorrectly assembled body and plunger assemblies will change the leak-down rate.</p>	72-20
High oil pressure	Relocated oil pressure take-off point on the engine	Use only the approved oil pressure take-off point.	
	Oil temperature is too cold	Before increasing the power control, allow the oil temperature to increase.	
	Oil pressure incorrectly adjusted	Adjust the oil pressure by turning the pressure adjustment on the oil pressure relief valve.	72-50

**Table 1 (Cont.)
Fault Isolation Guide**

Problem	Cause	Corrective Action	Ref.
High oil pressure (Cont.)	Incorrect weight of oil used	Use the recommended viscosity of oil for the ambient temperature per the latest revision of Service Instruction No. SI-1014.	
	Oil passage is blocked from the pressure relief valve to the sump	<ol style="list-style-type: none"> 1. Remove the pressure relief valve from the engine. 2. Push a soft copper wire through the oil passage to the oil sump to remove blockage. <p>NOTICE: If blockage continues, remove the oil sump and clean the passage.</p>	72-50
Sluggish propeller operation	Propeller oil control leak	Complete the "Propeller Oil Control Leak Test Procedure."	72-20
Engine does not hold rpm during cruise, climb, or descent	Propeller oil control leak	Complete the "Propeller Oil Control Leak Test Procedure."	72-20
Propeller goes into feather during landing rollout with decreased power setting	Propeller oil control leak	Complete the "Propeller Oil Control Leak test Procedure."	72-20

72-00 - ENGINE REMOVAL AND RETURN TO SERVICE

1. Engine Removal Prerequisites

⚠ WARNING: DURING ALL MAINTENANCE PROCEDURES AND INSPECTIONS, ENSURE THAT THE ENGINE IGNITION SWITCH IS IN THE 'OFF' POSITION, ALL POWER TO THE AIRCRAFT IS DISCONNECTED, AND ALL PERSONNEL ARE CLEAR OF THE PROPELLER'S ROTATIONAL ARC.

A. Before engine removal from the aircraft:

- (1) Make sure that all electrical switches, circuit breakers, Ignition Switch, and the Fuel Selector Valve are in the OFF position.
- (2) In accordance with the aircraft manufacturer's instructions, remove all cowling, baffling and nacelle access panels to enable engine removal.
- (3) Disconnect the ground terminal of the battery.
- (4) Disconnect the positive terminal of the battery.
- (5) Disconnect and examine the leads and wiring for damage or frayed wiring.
- (6) Remove a spark plug from each cylinder.
- (7) Remove the propeller in accordance with the aircraft manufacturer's instructions and/or propeller manufacturer's instructions.
- (8) Drain oil from engine. Refer to the "Oil Change Procedure" in Chapter 12-10.
- (9) Remove accessories.
- (10) If the engine is to be stored, complete the engine preservation procedure before engine removal. Refer to instructions in the *IO-390-C Series Engine Installation and Operation Manual*.

2. Engine Removal Procedure

- A. Complete the prerequisites in the section "Engine Removal Prerequisites" in this chapter.
- B. Document any indications of scoring, burning, fraying, chafing, unusual wear, or any other unacceptable condition found when removing engine parts, tubing, hoses, wiring and any other item disconnected for engine removal. Examine each removed component to determine if it is serviceable or must be replaced before returning the aircraft to service.
- C. Disconnect all connecting control cables.
- D. Disconnect any relays, gages, or other indicating devices as per the aircraft manufacturer's procedure.

⚠ CAUTION: USE CARE TO PREVENT DUST, DIRT, SAFETY WIRE, NUTS, SAFETY CABLE, WASHERS OR OTHER FOREIGN MATTER FROM ENTERING THE ENGINE. DURING ENGINE REMOVAL, IF ITEMS ACCIDENTALLY FALL INTO THE ENGINE, STOP WORK, FIND AND REMOVE ALL OF THE DROPPED ARTICLES. USE CORRECT PLUGS, CAPS, AND OTHER COVERINGS TO COVER EXPOSED OPENINGS. INSTALL DUST CAPS OVER, NOT IN, TUBE ENDS.
DO NOT PUT TAPE OR PLUGS INSIDE OPEN LINES OR FITTINGS.

- E. Apply a cap over oil and fuel lines and connections to prevent spillage and debris from entering the engine.
- F. Apply tags to identify ports, clips, tubes, wires, etc. for reference to make correct connections during engine installation. Identify the location of each part during removal. Attach a tag to unserviceable parts and units for examination or replacement.
- G. Disconnect the alternator from the engine.
- H. Remove all wiring bundle attaching clamps and hardware.
- I. Remove the manifold pressure gage line and aircraft fuel supply lines in accordance with the aircraft manufacturer's instructions.
- J. Refer to the aircraft manufacturer's instructions to disconnect any accessory connection or to remove any external accessories to enable removal of the engine from the aircraft.
- K. Make sure that all wires, lines, and attachments between the engine and airframe are disconnected and capped.
- L. Reinstall the spark plug in each cylinder.
- M. Attach an engine-lifting cable (with a minimum capacity of 750 lb (340 kg)) to the lifting straps on the engine in accordance with Figure 1.

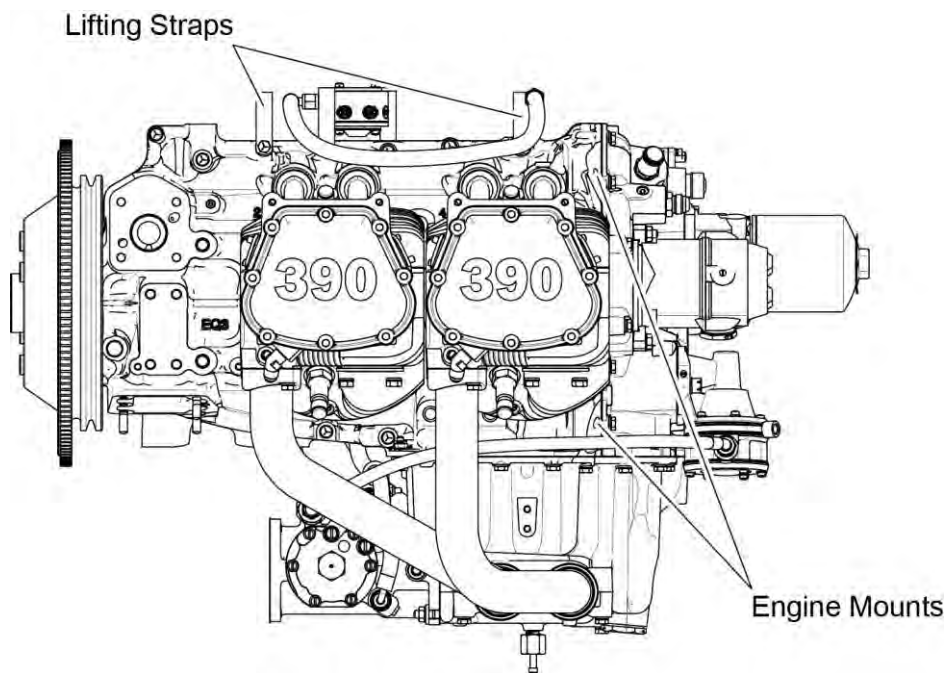


Figure 1
Lifting Straps and Engine Mounts

- N. Use a crane or overhead hoist (with a minimum load of 750 lb (340 kg)) to take up slack on the lifting cable until there is enough tension to hold the weight of the engine.
- O. Remove the nuts and bolts from the engine mounts that are supplied by the airframe manufacturer.

⚠ CAUTION: MAKE SURE THE AREA IS CLEAR WHEN LIFTING THE ENGINE. DO NOT ALLOW THE FRONT, REAR, SIDES OR BOTTOM OF THE ENGINE TO BUMP OR STRIKE ANY OBJECTS TO PREVENT DAMAGE TO THE ENGINE OR ITS COMPONENTS.

P. Carefully lift the engine slowly out of the airframe.

Q. Put the engine on an engine stand, transport dolly, or engine shipping container base.

3. Engine Installation Preparation Requirements

To prevent delays on engine re-installation, have the following materials and new spare parts identified in Table 1 available (Refer to the applicable parts catalog). Follow the procedures in Table 1 to prepare the engine for installation (if the engine was not in storage). If the engine was in storage, refer to the *IO-390-C Series Engine Installation & Operation Manual* for instructions to prepare an engine that has been in storage.

**Table 1
Materials and Procedures to Prepare a Serviced Engine for Installation**

New gaskets, seals, O-rings, and packing (Make sure the new parts are not brittle, torn, cut, or cracked and do not have flashings, deterioration/wear or deformities.)*	Always install new gaskets, seals, O-rings, or packing.
New safety wire/cable, lock nuts, lock washers, tab washers, and cotter pins	
New replacement part for any part that had to be discarded*	
Oil per specifications in Appendix A of the <i>IO-390-C Series Engine Installation and Operation Manual</i>	“Add Oil to the Engine” in Chapter 12-10
Cleaning solvents and lint-free wipes (identified in Chapter 05-30)	Cleaning procedures in Chapter 05-30
*Before installing a component, complete a check of the shelf-life of the part as per the latest revision of Service Letter No. L247	

After all inspections and maintenance tasks are complete, install the engine per the *IO-390-C Series Engine Installation and Operation Manual*.

During engine re-installation:

- A. Refer to and follow the "Maintenance Practices" in Chapter 05-00.
- B. Replace any gaskets, seals or packing that were removed with new parts.
- C. Replace any part that was damaged or that could not be repaired with a new part.
- D. Install external accessories as per the aircraft manufacturer's instructions.

4. Operational Ground Check

NOTICE: The purpose of this check is to make sure the installed engine operates in the aircraft according to specifications in Appendix A of the *IO-390-C Series Engine Installation and Operation Manual*.

- A. Per the component manufacturer's instructions, calibrate the cylinder head temperature gage, oil temperature gage, oil pressure gage, manifold pressure gage, and tachometer prior to testing.
- B. Make sure that all of the engine gages operate correctly.
- C. Make sure that the vent and breather lines are correctly installed and secured in accordance with the aircraft manufacturer's instructions.
- D. Install the cowling and all of the aircraft baffles per the aircraft manufacturer's instructions.
- E. Position the aircraft into the wind.
- F. Complete the applicable procedures in either the "Engine Initiation" chapter or "Engine Operation" chapter of the *IO-390-C Series Engine Installation and Operation Manual*.

NOTICE: Engine initiation procedures are to be done in the field on any of the following newly installed Lycoming engines:

- Any new, overhauled, or rebuilt engine from the factory and field-overhauled engines
- Engine taken out of storage (if not run-in when put in storage)
- An engine which has been disassembled/re-assembled

5. Idle Speed and Mixture Adjustment

NOTICE: The fuel injector servo has a speed adjustment screw to adjust the idle speed. Refer to Figure 2. There is also a mixture adjustment wheel on the throttle body to adjust the idle mixture. Refer to Figure 2.

NOTICE: The goal of this procedure is to adjust the idle speed and mixture to an optimum level.

- A. Start the engine and operate it until the oil and cylinder head temperatures are in the specified operating range shown in Appendix A of the *IO-390-C Series Engine Installation and Operation Manual*.

- B. Set the throttle stop screw to let the engine idle at idling rpm speed.

NOTICE: As needed, set fuel controls on new, rebuilt, or overhauled engine to 50 to 100 rpm higher than usual idle speed (600 to 700 rpm) for the first 25 hours of operation - then adjust to the usual setting after the first 25 hours of operation.

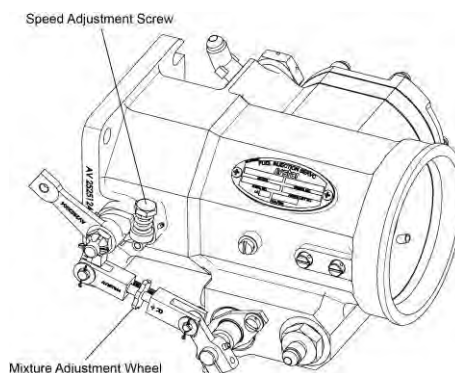


Figure 2
Speed Adjustment Screw and Mixture Adjustment Wheel on the Fuel Injector Servo

To adjust the idling speed to the desired rpm:

- (1) When the idle speed is stable, move the cockpit mixture control lever with a very slow, steady pull toward the IDLE CUT-OFF position, do not let the engine stop. While monitoring the tachometer, steadily move the mixture control lever to the FULL RICH position.
- (2) An increase of more than 50 rpm during fuel mixture adjustment is an indication of an excessively rich idle mixture. An immediate decrease in rpm (without an initial momentary increase) is an indication that the idle mixture is too lean. Adjust the fuel mixture as follows:

If the fuel mixture is too lean:

Turn the mixture adjustment wheel (Figure 2) at the side of the fuel injector servo toward "**R**" for *Rich*.

Turn the idle mixture adjustment wheel on the throttle body in the direction to *enrich* the fuel mixture.

If the fuel mixture is too rich:

Turn the mixture adjustment wheel (Figure 2) at the side of the fuel injector servo away from "**R**".

Turn the idle mixture adjustment wheel on the throttle body in the direction to *lean* the fuel mixture.

NOTICE: Run-up the engine to 2000 rpm to clear the engine each time you turn the idle mixture adjustment wheel to adjust the idle speed mixture.

- C. After the adjustment, run up the engine again to 2000 rpm. Complete the previous steps until the idle speed check shows a momentary increase of approximately 25 to 50 rpm.
 - D. Make the final idle speed adjustment for the desired idling rpm with a closed throttle.
 - E. If the idle speed setting is not stable after repeated attempts, complete a check of the idle linkage. Look for loose connections which could cause erratic idling. Also take into account weather conditions and field altitude which could affect the idle speed mixture adjustment.
6. Engine Mount Inspection
- A. Examine the engine mounts to make sure they are not cracked, damaged, or bent. Replace a cracked, damaged, or bent engine mount in accordance with the aircraft manufacturer's instructions.
 - B. Examine the engine mount bores for radial scoring. Replace the crankcase if radial scoring on the engine mount bores is more than 0.010 in. (0.254 mm) depth.
 - C. Examine the engine mounts for looseness. Tighten any loose hardware. Refer to the aircraft manufacturer's instructions.
 - D. Examine the rubber engine mounts and mounting hardware for signs of deterioration or damage. Replace worn or damaged engine mounts or hardware in accordance with the aircraft manufacturer's instructions.
 - E. After the first 100 hours of operation, make sure that the engine fastening nuts and bolts for the engine mounts are torqued correctly. For torque values, refer to the aircraft manufacturer's instructions.

7. Return to Service Procedure

Before returning this engine to service;

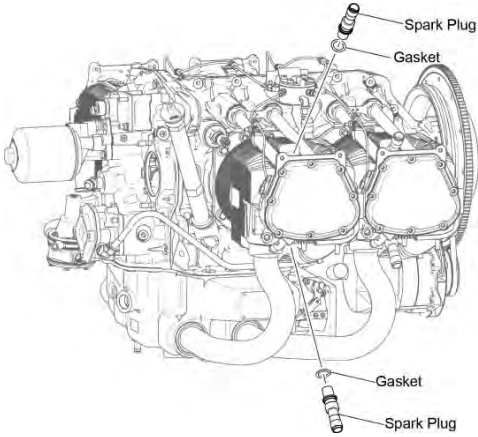
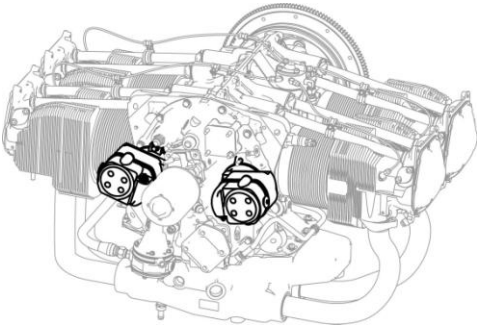
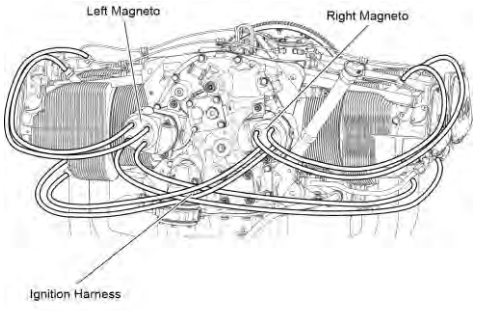
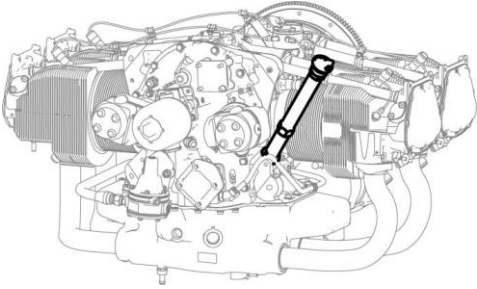
- Make sure that you correct all problems and complete all of the necessary maintenance.
- Complete the “Operational Ground Check” in this chapter.
- Specifically monitor:
 - Power output (static and idle rpm)
 - Fuel and oil pressure
 - Cylinder and oil temperatures

72-05- ENGINE DISASSEMBLY

Engine disassembly begins after the oil has been drained from the engine per instructions in Chapter 12-10, and the engine is removed from the airframe (per instructions in this manual and the applicable Airframe Maintenance Manual).

Follow the procedures for engine disassembly for the IO-390-C engine in the sequence identified in Table 1.

Table 1
Sequence of IO-390-C Engine Series Disassembly Procedures

Step	Reference	Step	Reference
<p>Step 1 Remove the spark plugs (Figure 1).</p>	<p>“Spark Plug Removal” procedure in Chapter 74-20</p>  <p>Figure 1 Spark Plugs</p>	<p>Step 3 Remove the two magnetos (Figure 3).</p>	<p>“Magneto Removal” procedure in Chapter 74-30</p>  <p>Figure 3 Magnetos</p>
<p>Step 2 Remove the ignition harness and ignition leads (Figure 2).</p>	<p>“Ignition Harness Removal” procedure in Chapter 74-20</p>  <p>Figure 2 Ignition Harness</p>	<p>Step 4 Remove the oil level gage assembly and oil level gage tube (Figure 4).</p>	<p>“Oil Level Gage Tube and Assembly Removal” procedure in Chapter 72-50</p>  <p>Figure 4 Oil Level Gage Tube</p>

**Table 1 (Cont.)
Sequence of IO-390-C Engine Series Disassembly Procedures**

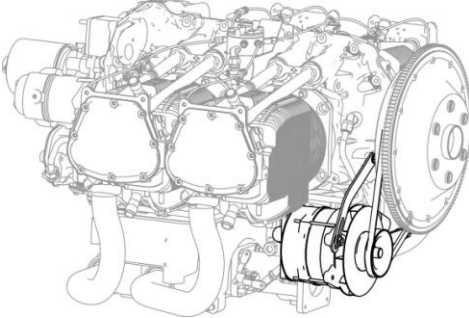
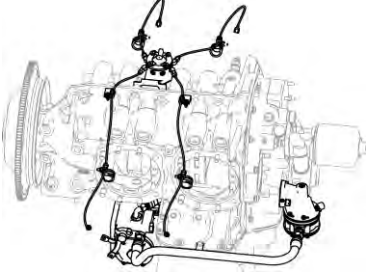
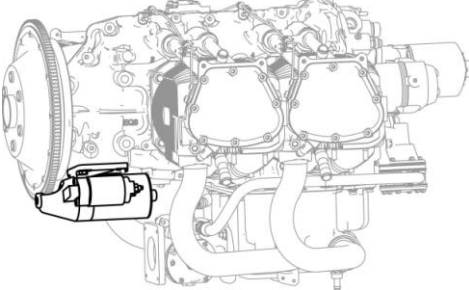
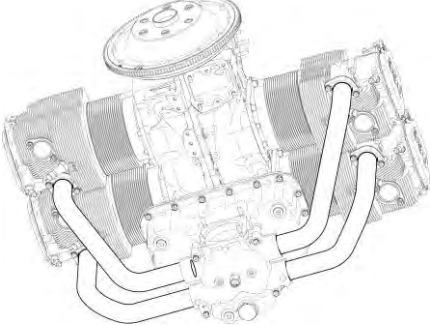
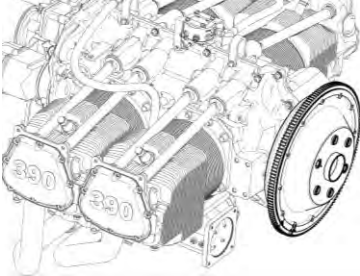
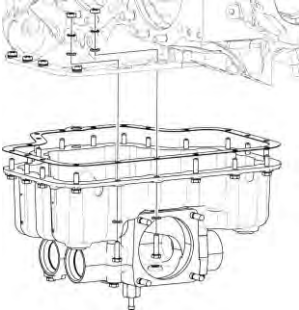
Step	Reference	Step	Reference
<p>Step 5 Remove the alternator, alternator bracket, and alternator belt (Figure 5).</p>	<p>“Alternator and Bracket Removal” and “Alternator Belt Removal” procedures in Chapter 72-70</p>  <p>Figure 5 Alternator Bracket, Alternator, and Alternator Belt</p>	<p>Step 8 Remove the fuel lines, fuel injector, injection nozzles, fuel manifold, and, fuel pump (Figure 8).</p>	<p>Procedures in Chapter 73-10</p> <ul style="list-style-type: none"> • Fuel Line Removal • Fuel Injector Removal • Injection Nozzle Removal • Fuel Manifold Removal • Fuel Pump Removal  <p>Figure 8 Fuel Lines and Fuel Components</p>
<p>Step 6 Remove the starter (Figure 6).</p>	<p>“Starter Removal” procedure in Chapter 72-70</p>  <p>Figure 6 Starter</p>	<p>Step 9 Remove the intake pipes (Figure 9).</p>	<p>“Intake Pipe Removal” procedure in Chapter 72-80</p>  <p>Figure 9 Intake Pipes</p>
<p>Step 7 Remove the starter ring gear support and starter ring gear (Figure 7).</p>	<p>“Starter Ring Gear Support Removal” and “Starter Ring Gear Removal” procedures in Chapter 72-70</p>  <p>Figure 7 Starter Ring Gear</p>	<p>Step 10 Remove the oil sump (Figure 10).</p>	<p>“Oil Sump Removal” procedure in Chapter 72-50</p>  <p>Figure 10 Oil Sump</p>

Table 1 (Cont.)
Sequence of IO-390-C Engine Series Disassembly Procedures

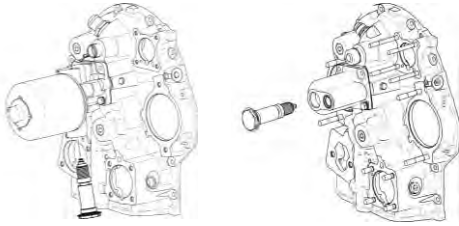
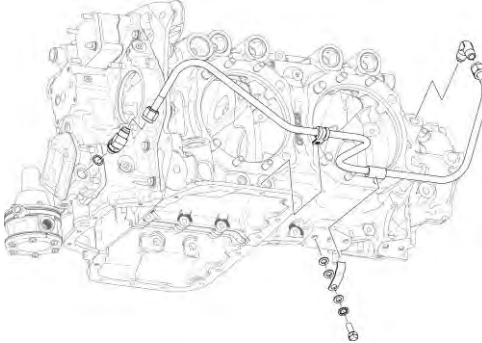

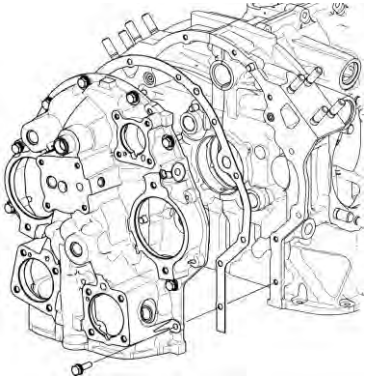
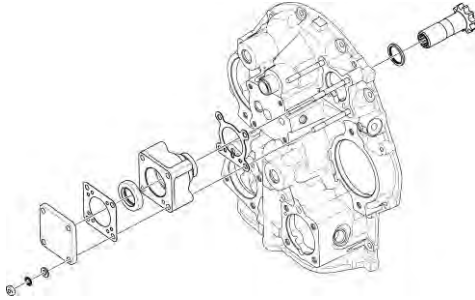
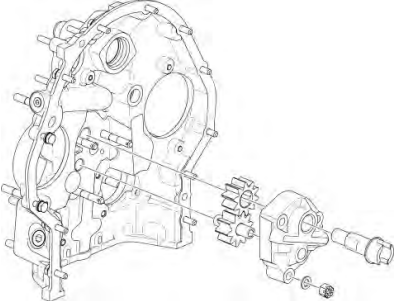
Step	Reference	Step	Reference
<p>Step 11 Remove the thermostatic oil cooler bypass valve, oil filter /oil pressure screen, oil filter base / oil pressure screen housing (Figure 11).</p>	<p>Procedures in Chapters 12-10 and 72-50</p>  <p>Figure 11 Thermostatic Oil Cooler Bypass Valve, Oil Filter /Oil Pressure Screen, Oil Filter Base / Oil Pressure Screen Housing</p>	<p>Step 14 Remove the propeller governor oil line (Engine with rear-mounted propeller governor drives) (Figure 14).</p>	<p>“Propeller Governor Oil Line Removal” procedure in Chapter 72-50</p>  <p>Figure 14 Propeller Governor Oil Line</p>
<p>Step 12 Remove the vacuum pump (if installed) (Figure 12).</p>	<p>“Vacuum Pump Removal” in Chapter 72-60</p>  <p>Figure 12 Vacuum Pump</p>	<p>Step 15 Remove the accessory housing (Figure 15).</p>	<p>“Accessory Housing Removal” in Chapter 72-25</p>  <p>Figure 15 Accessory Housing</p>
<p>Step 13 Remove the vacuum pump driven gear (Figure 13).</p>	<p>“Vacuum Pump Driven Gear Removal” procedure in Chapter 72-60</p>  <p>Figure 13 Vacuum Pump Driven Gear</p>	<p>Step 16 Remove the oil pump and the fuel pump plunger (Figure 16).</p>	<p>“Oil Pump Removal” and “Fuel Pump Plunger Removal” procedures in Chapter 72-25</p>  <p>Figure 16 Oil Pump</p>

Table 1 (Cont.)
Sequence of IO-390-C Engine Series Disassembly Procedures

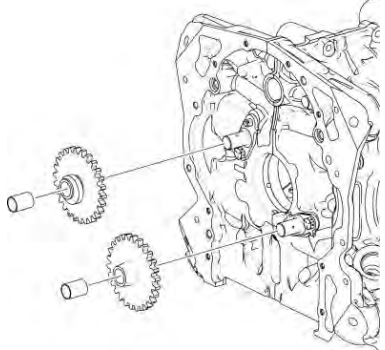
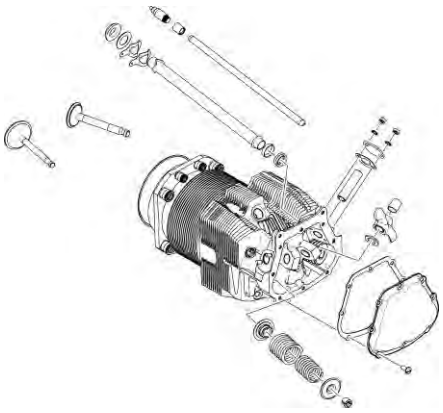
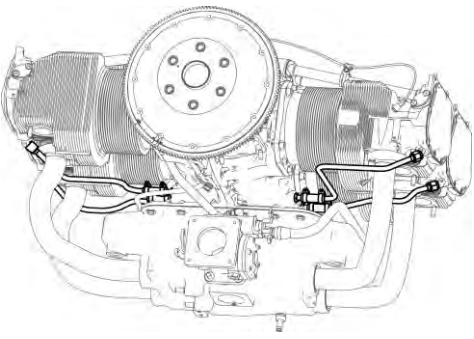
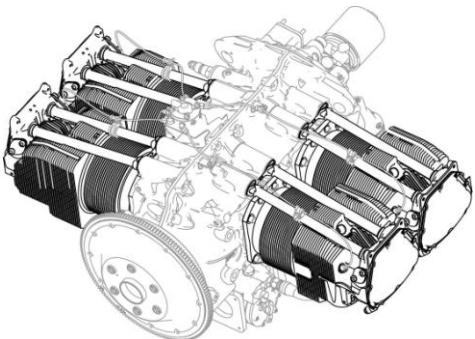
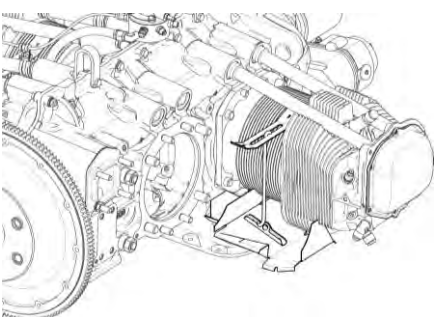
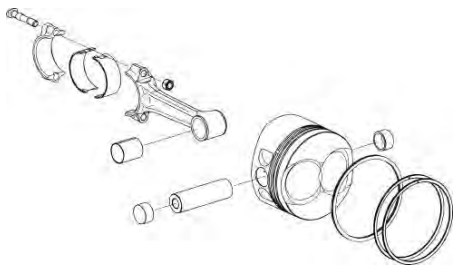
Step	Reference	Step	Reference
<p>Step 17 Remove both crankshaft idler gears (Figure 17).</p>	<p>“Crankshaft Idler Gear and Bushing Removal” procedure in Chapter 72-20</p>  <p>Figure 17 Crankshaft Idler Gears</p>	<p>Step 20 Remove the rocker covers, valve rockers, rocker shafts, push rods, and shroud tubes (Figure 20).</p>	<p>Chapter 72-30 in this manual</p>  <p>Figure 20 Rockers, Shroud Tubes, and Push Rods</p>
<p>Step 18 Remove the oil drain tubes from the engine cylinder heads and crankcase (Figure 18).</p>	<p>“Oil Drain Tube Removal” procedure in Chapter 72-30</p>  <p>Figure 18 Oil Drain Tubes</p>	<p>Step 21 Remove the engine cylinders (Figure 21).</p>	<p>“Cylinder Removal” procedure in Chapter 72-30</p>  <p>Figure 21 Engine Cylinders</p>
<p>Step 19 Remove the inter-cylinder baffles (Figure 19).</p>	<p>“Intercylinder Baffle Removal” procedure in Chapter 72-30</p>  <p>Figure 19 Intercylinder Baffles</p>	<p>Step 22 Remove the pistons (Figure 22).</p>	<p>“Piston Removal” procedure in Chapter 72-30</p>  <p>Figure 22 Piston</p>

Table 1 (Cont.)
Sequence of IO-390-C Engine Series Disassembly Procedures

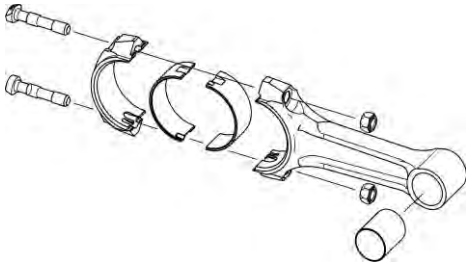
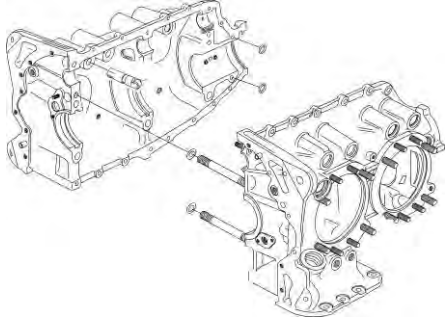
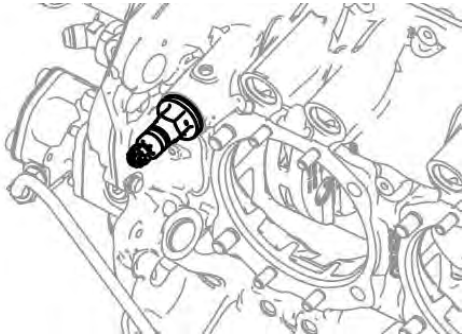
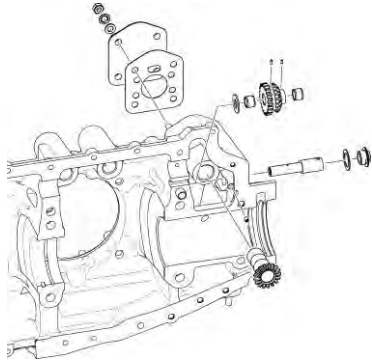
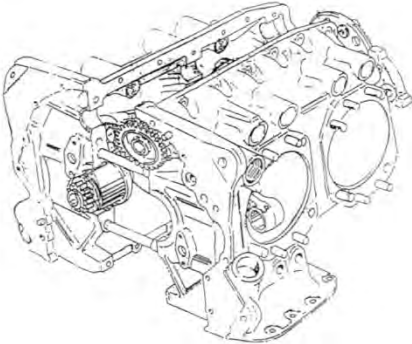
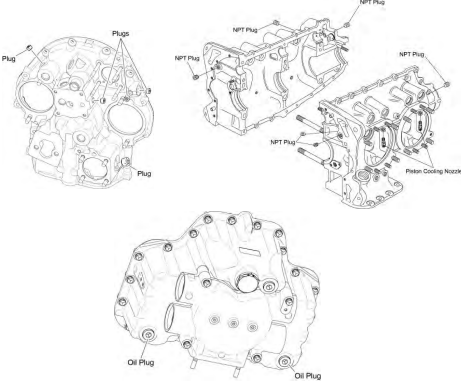
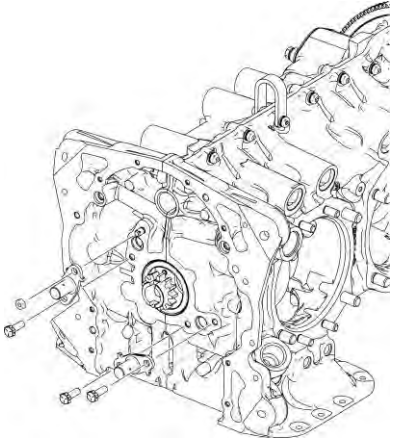
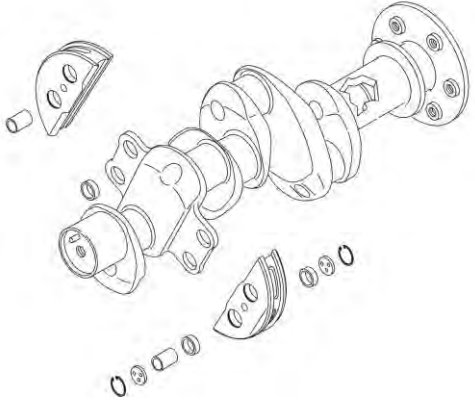
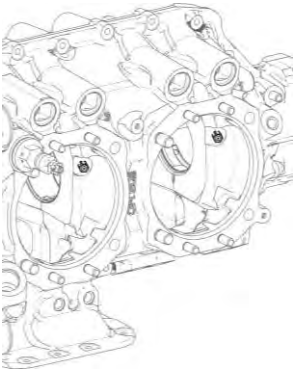
Step	Reference	Step	Reference
<p>Step 23 Remove the connecting rods (Figure 23).</p>	<p>“Connecting Rod Removal” in Chapter 72-20</p>  <p>Figure 23 Connecting Rod</p>	<p>Step 26 Remove the tappets, main bearings, and O-rings (Figure 26).</p>	<p>“Tappet, Main Bearing and O-Ring Removal” in Chapter 72-20</p>  <p>Figure 26 Tappets, Main Bearings and O-Rings</p>
<p>Step 24 Remove the oil pressure relief valve (Figure 24).</p>	<p>“Oil Pressure Relief Valve Removal” procedure in Chapter 72-50</p>  <p>Figure 24 Oil Pressure Relief Valve</p>	<p>Step 27 Remove the propeller governor drive (Engine with front-mounted propeller governor drives) (Figure 27).</p>	<p>“Propeller Governor Drive Removal/Disassembly” in Chapter 72-20</p>  <p>Figure 27 Propeller Governor Drive</p>
<p>Step 25 Separate the crankcase halves (Figure 25).</p>	<p>“Crankcase Disassembly” procedure in Chapter 72-20</p>  <p>Figure 25 Crankcase Halves</p>	<p>Step 28 Remove the oil plugs (Figure 28).</p>	<p>“Oil Plug Removal” procedure in Chapter 72-20</p>  <p>Figure 28 Oil Plugs</p>

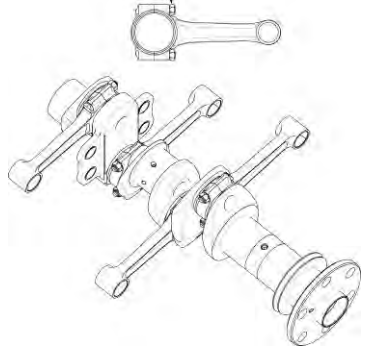
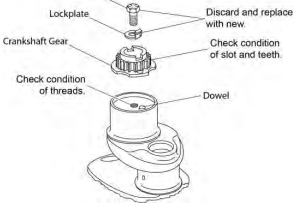
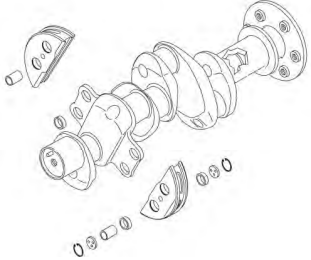
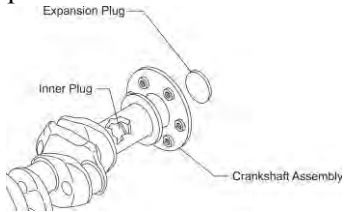
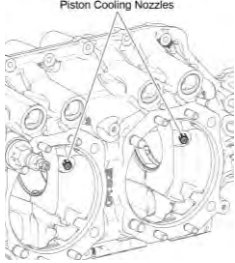

Table 1 (Cont.)
Sequence of IO-390-C Engine Series Disassembly Procedures

Step	Reference	Step	Reference
<p>Step 29 Remove the crankshaft idler gear shafts (Figure 29).</p>	<p>“Crankshaft Idler Gear Shaft Removal” procedure in Chapter 72-20</p>  <p>Figure 29 Crankshaft Idler Gear Shafts</p>	<p>Step 31 Disassemble the crankshaft (Figure 31).</p>	<p>“Crankshaft Disassembly” in Chapter 72-20</p>  <p>Figure 31 Crankshaft Disassembled</p>
<p>Step 30 Remove the piston cooling nozzles (Figure 30).</p>	<p>“Piston Cooling Nozzle Removal” in Chapter 72-20</p>  <p>Figure 30 Piston Cooling Nozzles</p>		

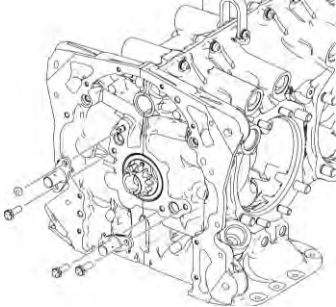
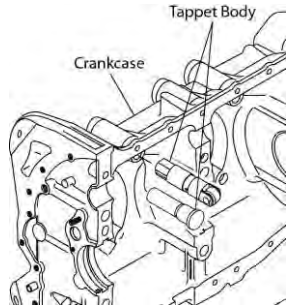
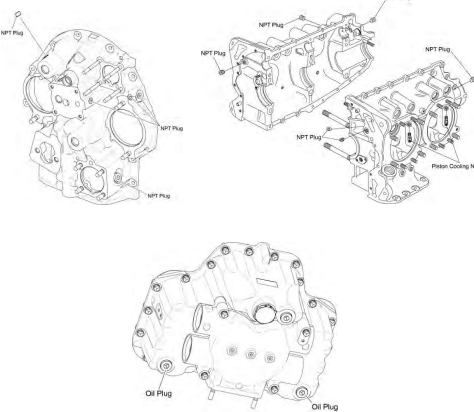
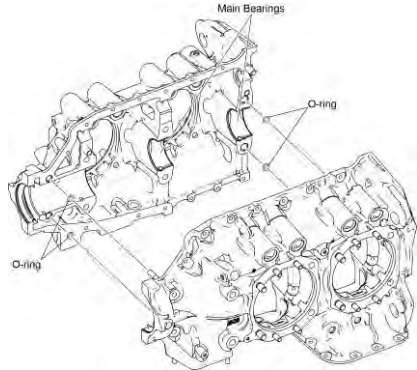
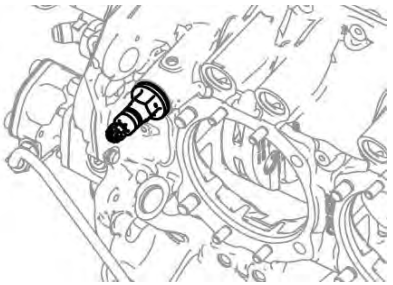
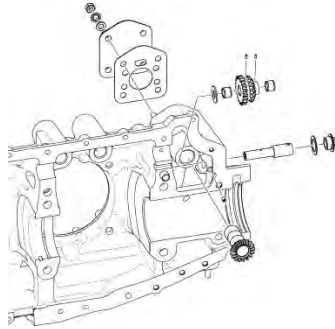
72-10 - ENGINE ASSEMBLY

1. Engine Assembly Procedure
 - A. Complete the sequence of steps in Table 1.
 - B. Complete the *Engine Assembly Checklist* in the chapter.

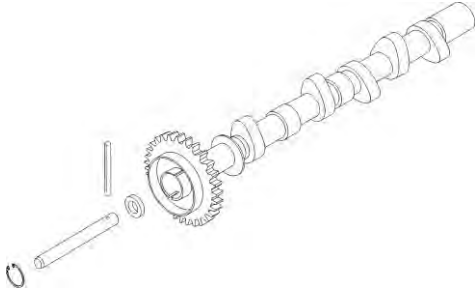

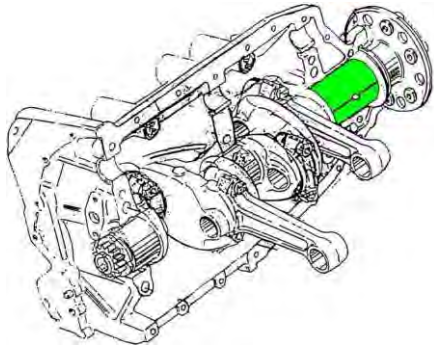
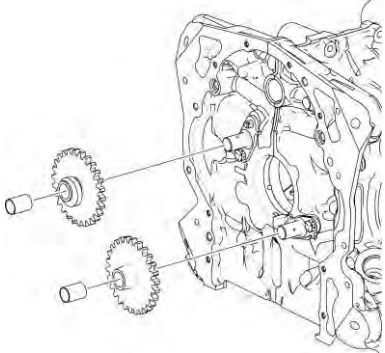
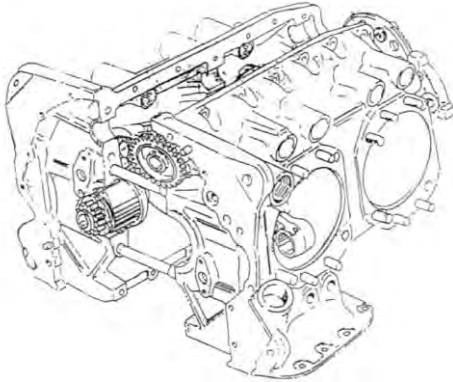
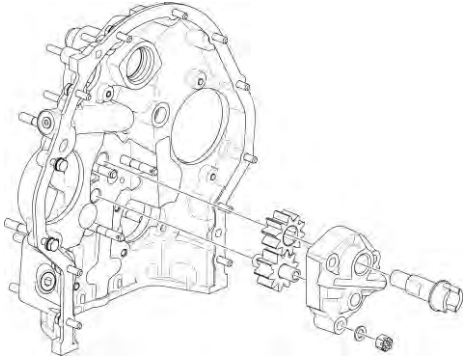
**Table 1
Sequence of IO-390-C Engine Series Assembly Procedures**

Step	Reference	Step	Reference
Step 1	Review the “General Assembly Practices” in this chapter	Step 5	“Connecting Rod Installation” procedure in Chapter 72-20
<p>Begin the “Crankshaft Assembly” procedure in Chapter 72-20.</p> <p>Examine the alignment dowel, and if necessary, replace the alignment dowel.</p>		<p>Install the connecting rods on the crankshaft (Figure 4).</p>	 <p align="center">Figure 4 Connecting Rods</p>
<p>Step 2</p> <p>Install the crankshaft gear on the crankshaft (Figure 1).</p>	<p>“Crankshaft Gear Installation” procedure in Chapter 72-20</p>  <p align="center">Figure 1 Crankshaft Gear</p>	<p>Step 6</p> <p>Install the counterweights on the crankshaft (Figure 5).</p>	<p>“Counterweight Installation” procedure in Chapter 72-20</p>  <p align="center">Figure 5 Counterweights</p>
<p>Step 3</p> <p>Install the expansion plug on the crankshaft (Figure 2).</p>	<p>“Expansion Plug Installation” procedure in Chapter 72-20</p>  <p align="center">Figure 2 Expansion Plug</p>	<p>Step 7</p> <p>Install the piston cooling nozzle (if removed) (Figure 6).</p>	<p>“Piston Cooling Nozzle Installation (if removed)” procedure in Chapter 72-20</p>  <p align="center">Figure 6 Piston Cooling Nozzles</p>
<p>Step 4</p> <p>Start installation of the solid-ring crankshaft oil seal on the crankshaft (Figure 3). (or install the oil seal later on)</p>	<p>“Solid-Ring Crankshaft Oil Seal Installation” procedure in Chapter 72-20</p>  <p align="center">Figure 3 Solid-Ring Crankshaft Oil Seal</p>		

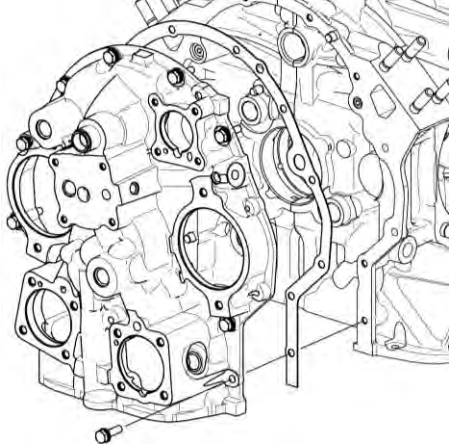
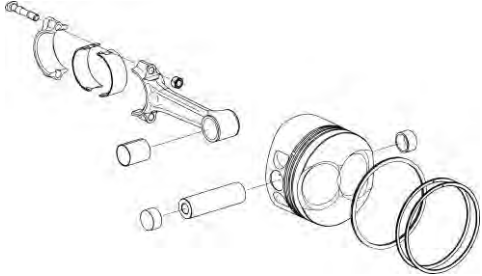
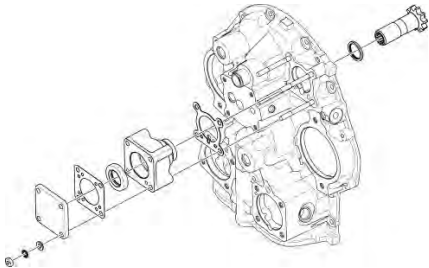
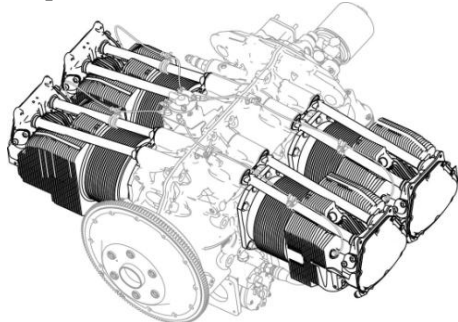

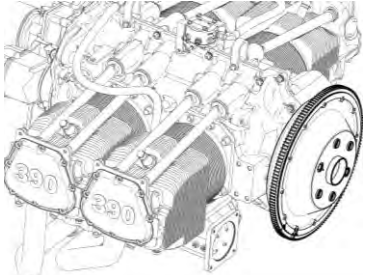
**Table 1 (Cont.)
Sequence of IO-390-C Engine Series Assembly Procedures**

Step	Reference	Step	Reference
<p>Step 8 Install the crankshaft idler gear shafts (Figure 7).</p>	<p>“Crankshaft Idler Gear Shaft Installation” procedure in Chapter 72-20</p>  <p>Figure 7 Crankshaft Idler Gear Shafts</p>	<p>Step 11 Install the tappet assemblies (Figure 10).</p>	<p>“Tappet Assembly Installation” procedure in Chapter 72-20</p>  <p>Figure 10 Tappets and Oil Seal Rings</p>
<p>Step 9 Install the oil plugs (if removed) (Figure 8).</p>	<p>“Oil Plug Installation” procedure in Chapter 72-20</p>  <p>Figure 8 Oil Plugs</p>	<p>Step 12 Install the main bearings, bolts, and O-rings in the crankcase (Figure 11).</p>	<p>“Crankshaft Bearing and O-Ring Installation” procedure in Chapter 72-20</p>  <p>Figure 11 Main Bearings and O-Rings</p>
<p>Step 10 Install the oil pressure relief valve (Figure 9).</p>	<p>“Oil Pressure Relief Valve Installation” procedure in Chapter 72-50</p>  <p>Figure 9 Oil Pressure Relief Valve</p>	<p>Step 13 Install the propeller governor drive (Engine with front-mounted propeller governor drives) (Figure 12).</p>	<p>“Propeller Governor Drive Installation” in Chapter 72-20</p>  <p>Figure 12 Propeller Governor Drive</p>

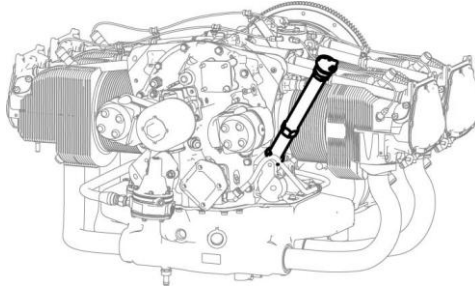
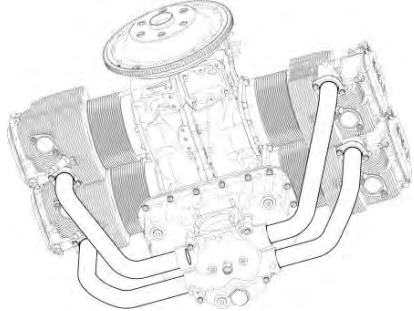
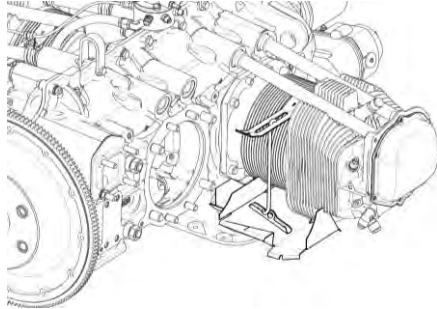
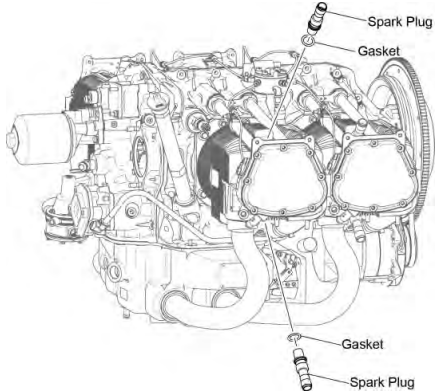
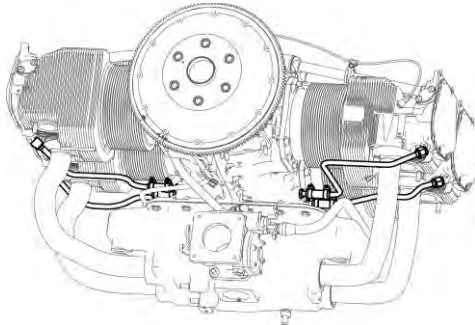
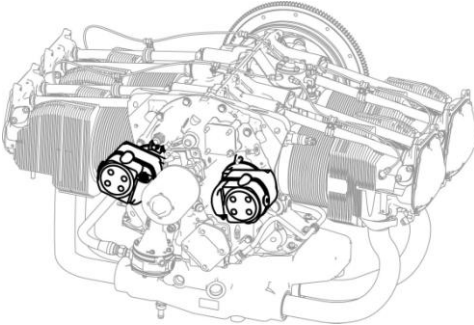
**Table 1 (Cont.)
Sequence of IO-390-C Engine Series Assembly Procedures**

Step	Reference	Step	Reference
<p>Step 14 Assemble and install the camshaft in the crankcase (Figure 13).</p>	<p>“Camshaft Assembly and Installation” procedure in Chapter 72-20</p>  <p>Figure 13 Camshaft</p>	<p>Step 17 Install the crankshaft oil seal in the crankcase (Figure 16)</p>	<p>“Crankshaft Oil Seal Installation” procedure in Chapter 72-20</p>  <p>Figure 16 Split Oil Seal and Solid-Ring Oil Seal</p>
<p>Step 15 Install the crankshaft in the crankcase (Figure 14).</p>	<p>“Crankshaft Installation” procedure in Chapter 72-20</p>  <p>Figure 14 Crankshaft</p>	<p>Step 18 Install the crankshaft idler gears (Figure 17).</p>	<p>“Crankshaft Idler Gear Installation” procedure in Chapter 72-20</p>  <p>Figure 17 Crankshaft Idler Gears</p>
<p>Step 16 Assemble the crankcase halves (Figure 15)</p>	<p>“Crankcase Assembly” procedure in Chapter 72-20</p>  <p>Figure 15 Crankcase Halves</p>	<p>Step 19 Install the oil pump and fuel pump plunger on the accessory housing (Figure 18).</p>	<p>“Oil Pump Installation” and “Fuel Pump Plunger Installation” procedures in Chapter 72-25</p>  <p>Figure 18 Oil Pump</p>

**Table 1 (Cont.)
Sequence of IO-390-C Engine Series Assembly Procedures**

Step	Reference	Step	Reference
<p>Step 20 Install the accessory housing, fuel pump, oil filter base, and oil filter or oil pressure screen housing, thermostatic oil cooler bypass valve, and rear-mounted propeller governor drive (Figure 19)</p>	<p>Chapters 72-25, 72-50, 72-60, and 73-10 in this manual and Airframe Manufacturer’s Maintenance Manual</p>  <p>Figure 19 Accessory Housing</p>	<p>Step 23 If removed install the piston in each engine cylinder (Figure 22)</p>	<p>“Piston Installation” procedure in Chapter 72-30</p>  <p>Figure 22 Piston</p>
<p>Step 21 Install the vacuum pump driven gear and vacuum pump (Figure 20)</p>	<p>“Vacuum Pump Driven Gear Installation” and “Vacuum Pump Installation” procedures in Chapter 72-60</p>  <p>Figure 20 Vacuum Pump Driven Gear</p>	<p>Step 24 Install all four engine cylinders on the crankcase (Figure 23)</p>	<p>“Cylinder Installation” section in Chapter 72-30</p>  <p>Figure 23 Engine Cylinders</p>
<p>Step 22 Install the oil sump on the crankcase (Figure 21)</p>	<p>“Oil Sump Installation” in Chapter 72-50</p>  <p>Figure 21 Oil Sump</p>	<p>Step 25 Install the starter ring gear support on the engine (Figure 24).</p>	<p>“Starter Ring Gear Support Installation” procedure in Chapter 72-70</p>  <p>Figure 24 Starter Ring Gear</p>

**Table 1 (Cont.)
Sequence of IO-390-C Engine Series Assembly Procedures**

Step	Reference	Step	Reference
<p>Step 26 Install the oil level gage assembly and oil level gage tube (Figure 25).</p>	<p>“Oil Level Gage Tube and Assembly Installation” procedure in Chapter 72-50</p>  <p>Figure 25 Oil Level Gage Tube</p>	<p>Step 29 Install the intake pipes, each to the corresponding cylinder (Figure 28).</p>	<p>“Intake Pipe Installation” procedure in Chapter 72-80</p>  <p>Figure 28 Intake Pipes</p>
<p>Step 27 Install inter-cylinder baffles (Figure 26).</p>	<p>“Intercylinder Baffle Installation” procedure in Chapter 72-30</p>  <p>Figure 26 Intercylinder Baffle</p>	<p>Step 30 Examine, set the gap, and install all spark plugs (one in the top and bottom of each engine cylinder) per the rotation sequence (Figure 29).</p>	<p>“Spark Plug Gap Setting” and “Spark Plug Installation” procedures in Chapter 74-20</p>  <p>Figure 29 Spark Plugs</p>
<p>Step 28 Attach four new oil drain tubes, one on each engine cylinder head and the crankcase (Figure 27).</p>	<p>“Oil Drain Tube Installation” procedure in Chapter 72-30</p>  <p>Figure 27 Oil Drain Tubes</p>	<p>Step 31 Install both magnetos on the engine (Figure 30).</p>	<p>“Magneto Installation” procedure in Chapter 74-30</p>  <p>Figure 30 Magnetos</p>

**Table 1 (Cont.)
Sequence of IO-390-C Engine Series Assembly Procedures**

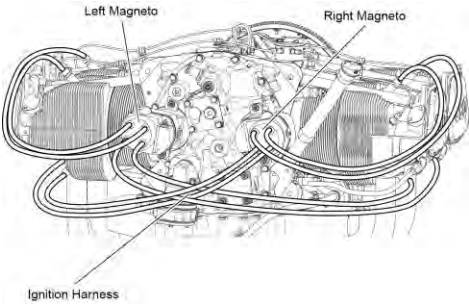
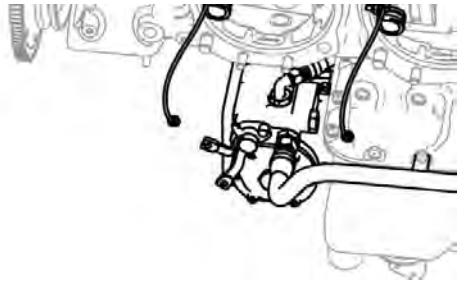
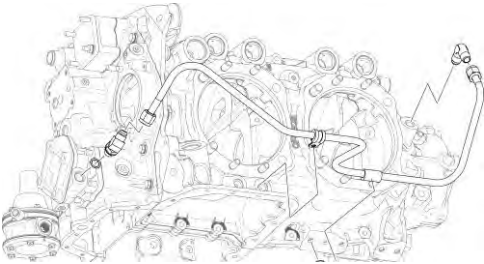
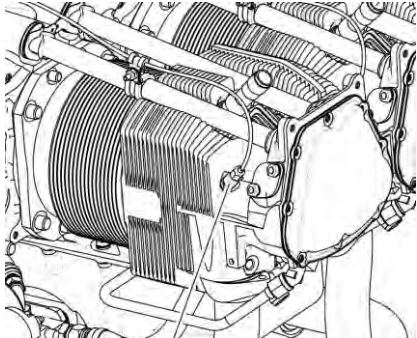
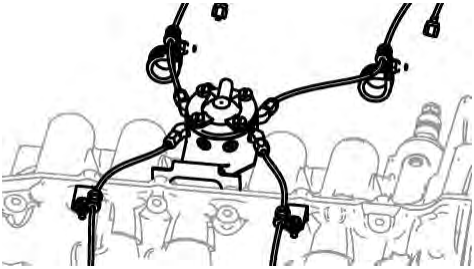
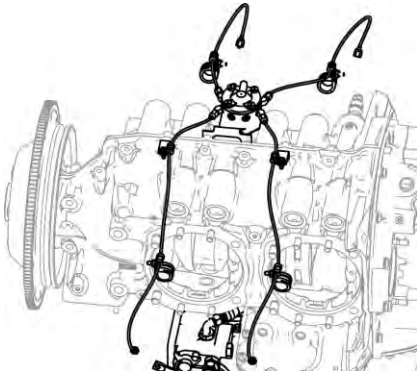
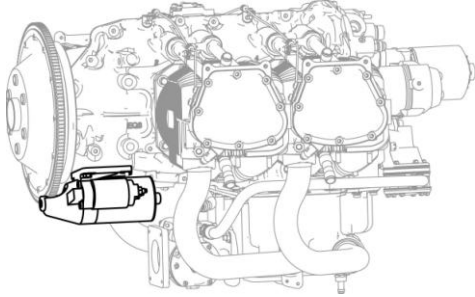
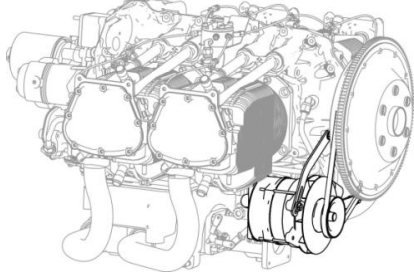
Step	Reference	Step	Reference
<p>Step 32 Install the ignition harness on the engine (Figure 31).</p>	<p>“Ignition Harness Installation” procedure in Chapter 74-20</p>  <p>Figure 31 Ignition Harness</p>	<p>Step 35 Install the fuel injector (Figure 34).</p>	<p>“Fuel Injector Installation” procedure in Chapter 73-10</p>  <p>Figure 34 Fuel Injector</p>
<p>Step 33 Install the propeller governor oil line (Engine with rear-mounted propeller governor drives) (Figure 32).</p>	<p>“Propeller Governor Oil Line Installation” procedure in Chapter 72-50</p>  <p>Figure 32 Propeller Governor Oil Lines</p>	<p>Step 36 Install the injection nozzles (Figure 35).</p>	<p>“Injection Nozzle Installation” procedure in Chapter 73-10</p>  <p>Figure 35 Injection Nozzles</p>
<p>Step 34 Install the fuel manifold (Figure 33).</p>	<p>“Fuel Manifold Installation” procedure in Chapter 73-10</p>  <p>Figure 33 Fuel Manifold</p>	<p>Step 37 Install the fuel lines (Figure 36).</p>	<p>“Fuel Line Installation” procedure in Chapter 73-10</p>  <p>Figure 36 Fuel Lines</p>

Table 1 (Cont.)
Sequence of IO-390-C Engine Series Assembly Procedures

<p>Step 38 Install the starter (Figure 37).</p>	<p>“Starter Installation” procedure in Chapter 72-70</p>  <p align="center">Figure 37 Starter</p>	<p>Step 39 Install the alternator, bracket, and belt (Figure 38).</p>	<p>“Alternator and Bracket Installation” and “Alternator Belt Installation” procedures in Chapter 72-70</p>  <p align="center">Figure 38 Alternator Bracket, Alternator, and Alternator Belt</p>
<p>Step 40 Install the Engine in the Airframe</p> <p>Install the engine in the airframe per instructions in this manual, <i>IO-390-C Series Engine Installation and Operation Manual</i>, and applicable Airframe Maintenance Manual.</p>			

General Assembly Practices

1. Corrosion Prevention

⚠ CAUTION: USE ONLY THE RECOMMENDED LUBRICANT OR EQUIVALENT DURING ENGINE ASSEMBLY.

A. Pre-Lubrication of Parts Before Assembly

Before assembly of each subassembly, clean all of the parts to remove the preservative oil, grease, and unwanted dirt per instructions in Chapter 05-30.

As preventive action, during engine assembly, apply the recommended lubricant for specified components identified in the latest revision of Service Instruction No. SI-1059.

If parts are not correctly lubricated, or if a lubricant other than what is recommended is applied to a part, engine parts could become scored before the engine oil has lubricated the parts during the first cycle of engine operation. This scoring can cause premature part failure, or, in some cases, engine failure.

2. Painting the Engine and Engine Components

Lycoming Engines recommends that the basic engine be painted as an assembly (without accessories, intake tubes, fluid lines, wiring harness). However, if it is necessary to paint an individual component:

- Do not get paint on any mating surfaces or under the cylinder hold down nuts.
- There must be metal-to-metal contact to ensure correct torque.
- Mask mating surfaces and the area where the nut will contact the component surface.

Table 2 includes paint stripping and painting guidelines for components.

All paint is to be sprayed; however, if it is necessary to use a brush, use care to prevent an accumulation of pockets of paint. Refer to the paint manufacturer’s instructions for drying and curing times.

Parts requiring use of paint for protection or appearance are to be painted in accordance with the recommendations using the following approved materials:

- Thinner - Toluene or equivalent (AMS3180 or equivalent Federal Spec. TT-T-548).
- Primer - Zinc chromate (AMS3110 or equivalent MIL-P-8585).
- Enamel - Phthalate resin type (AMS3125C or equivalent MIL- E-7729).

NOTICE: All machined bosses are to be masked before painting. Do not paint areas under hold-down nuts where torque is required.

Table 2
Paint Stripping and Painting Guidelines for Components

Aluminum and Steel Parts	<p>NOTICE: It is not necessary to apply the primer coat if paint has not been removed from the part.</p> <ol style="list-style-type: none"> (1) Clean and degrease the parts with mineral spirits or equivalent. (2) Apply one coat of zinc chromate primer, thinned with two parts toluene. (3) Air dry. (4) Apply one coat of enamel and bake at 250° to 300° F (121 to 149° C), for 1/2-hour.
Magnesium Parts	<ol style="list-style-type: none"> (1) Clean all traces of oil and grease from the part using a neutral, non-corrosive, degreasing medium followed by a rinse. (2) Immerse the part for 45 minutes in a hot dichromate solution (3/4 lb. (0.34 kg) of sodium dichromate to 1 gallon (3.8 liters) of water at 180° to 200°F (82° to 93°C) (as required). (3) Wash the part thoroughly in cold running water, dipped in hot water, and dried in an air blast. (4) Immediately paint the part with a primer coat and engine enamel, the same as aluminum parts.
Shroud Tubes	<ol style="list-style-type: none"> (1) Clean and degrease the shroud tube with mineral spirits or equivalent. (2) Dip the shroud tube in zinc chromate primer, thinned to spraying consistency. (3) Let the primer coat dry. (4) Paint the outside of the shroud tube with engine enamel.

**Table 2 (Cont.)
Paint Stripping and Painting Guidelines for Components**

Cylinder Painting	<p><u>NOTICE:</u> Paint the cylinder with a Phthalate resin type enamel (AMS3125C or equivalent MIL-E-7729) properly thinned with Toluene or equivalent (AMS3180 or equivalent Federal Spec. TT-T-548).</p> <p>(1) Remove all old paint from the cylinder.</p> <p>Paint strippers are usually organic solvents like MEK or acetone or toluene, etc. and typically will not cause any damage to metals. A vapor degreaser is best suited for this purpose.</p> <p><u>NOTICE:</u> Masking tape, corks, plugs, metal covers, etc. are acceptable for masking purposes.</p> <p>(2) Mask off the following parts of the cylinder:</p> <ul style="list-style-type: none"> • Rocker box section, including the rocker box flange • Both valve ports and flanges • Thermocouple hole • Spark plug holes • Push rod shroud tube holes • All other exposed threaded surfaces in which paint could accumulate <p><u>NOTICE:</u> In the next step, maximum thickness of the paint on the cylinder flange must be 0.0005 in. (0.0127 mm). Measure the thickness of the paint with a thickness gage or equivalent. If a thickness gage is not available, use a micrometer to measure the thickness of the flange before and after painting. If the paint is over 0.0005 in. (0.0127 mm) thick, remove the paint and repaint the cylinder flange.</p> <p>(3) Apply a very light sprayed coat of zinc chromate primer to a maximum thickness of (0.0005 in. (0.0127 mm) on the cylinder flange. If the correct amount of paint has been applied, the color of the paint will be green with a yellowish tint and the metal will show through. If the paint is too thick, the color will be zinc chromate yellow.</p> <p>(4) Cover the flange area to prevent paint being applied where the cylinder hold-down nuts contact the cylinder flange.</p> <p>(5) Use a cloth dipped in paint thinner to remove paint from all surfaces where it could have accidentally accumulated.</p> <p>(6) Air-dry the cylinder or bake the cylinder in an oven until completely dry. Refer to the paint manufacturer's instructions for drying time and oven temperature.</p> <p>(7) Refer to Chapter 74-20 and paint the cylinder fin area appropriately for spark plug identification.</p>
-------------------	--

3. Limits and Clearances

Refer to the latest revision of *Service Table of Limits - SSP-1776*, for the following.

- Backlash and end clearance of gears
- Clearance between mating machined parts
- Clearance between moving parts that touch
- Torque limits for various nuts, screws, and fasteners.

4. Inspections

A. Bearing Surface Inspection

- (1) Examine all bearing surfaces for scoring, galling, and wear. If a part has one of the defects, discard it and replace it with a new one.
- (2) Make sure that the clearance of each bearing agrees with the specification in the latest revision of the *Service Table of Limits SSP-1776*.
- (3) If a bearing is not in the specified limits in the latest revision of the *Service Table of Limit - SSP-1776*, discard it and replace it with a new one.
- (4) Examine all journal surfaces for galling, scores, misalignment, and out-of-round condition. Replace a scored, galled, misaligned, or out-of-round component.
- (5) Examine the shafts and pins for straightness.

B. Gear Inspection

- (1) Examine the involutes of the gear teeth for pitting and excessive wear.
- (2) If pit marks are found, discard the gear and replace it with a new one.
- (3) Examine the bearing surfaces of all gears for deep scratches.
- (4) Remove minor abrasions with a fine abrasive cloth.

C. Screwed Fitting Inspection

- (1) Examine the condition of the threads on screwed fittings (threaded fastenings or plugs).
- (2) Remove small nicks and burrs with a small file, fine abrasive cloth, or stone.
- (3) If the part cannot be repaired by polishing it, discard it and replace it with a new one.
- (4) If the part has too much distortion, galling, or mutilation (caused by over-tightening or use of an incorrect tool) replace it.

Engine Assembly Checklist

The Engine Assembly Checklist for IO-390-C Series Engines is a guide and a record of completion for engine assembly.

Engine Assembly Checklist for IO-390-C Series Engines		
Engine Model Number _____ Engine Serial Number: _____		
Engine Time: _____ Date of Engine Assembly: _____		
Engine Assembly done by: _____		
Item	Comments	Done
Review the “General Assembly Practices” in this chapter and the latest revision of Service Bulletin No. SB-240 to identify all parts that must be replaced with new parts upon removal..		
Start with a clean crankshaft which passed the “Crankshaft Inspection” in Chapter 72-20		
Complete the “Alignment Dowel Inspection” and if necessary, replace the alignment dowel per instructions in Chapter 72-20.		
<p>⚠ CAUTION: FOR CORRECT ENGINE OPERATION, THE CRANKSHAFT GEAR MUST BE INSTALLED CORRECTLY WITH NO GAP IN THE MATING SURFACES BETWEEN COUNTERBORED-END OF THE CRANKSHAFT AND THE CRANKSHAFT GEAR.</p>		
Complete the “Crankshaft Gear Installation” with a new crankshaft gear bolt and new lockplate Chapter 72-20.		
Install a new expansion plug in the crankshaft per the “Expansion Plug Installation” procedure in Chapter 72-20.		
Either begin installation of a new solid-ring oil seal on the crankshaft per the “Solid-Ring Crankshaft Oil Seal Installation” procedure in Chapter 72-20 or later on install a split oil seal per the “Crankshaft Oil Seal Installation” procedure in Chapter 72-20.		
Complete the “Connecting Rod Inspection” in Chapter 72-20.		
Per the “Connecting Rod Installation“ section in Chapter 72-20: <ul style="list-style-type: none"> • Measure the inside diameter of the bearing The clearance is to be 0.004 to 0.016 in. (service) and 0.004 to 0.010 in. (on rebuilt engines). Compare the results to the measurements previously recorded. • Assemble and install the connecting rods (on the crankshaft) each with a pair of new bearing inserts, a new connecting rod bolt, and a new nut. 	Measurement	

Engine Assembly Checklist for IO-390-C Series Engines (Cont.)		
Item	Comments	Done
Install counterweights on the crankshaft per the “Counterweight Installation” procedure in Chapter 72-20.		
Start with a clean crankcase which passed the “Crankcase Inspection Before Disassembly” and “Crankcase Dimensional Inspection” in Chapter 72-20.		
Complete the “Piston Cooling Nozzle Installation” procedure in Chapter 72-20.		
Complete the “Crankshaft Idler Gear Shaft Installation” procedure in Chapter 72-20.		
Install the oil plugs (if removed) per the “Oil Plug Installation” procedure in Chapter 72-20.		
Complete the “Oil Pressure Relief Valve Installation” procedure in Chapter 72-50.		
Complete the “Tappet Assembly Installation” procedure on Chapter 72-20. Identify the types of tappets installed in the engine logbook.		
Complete the “Crankshaft Bearing and O-Ring Installation” procedure in Chapter 72-20.		
Complete the “Propeller Governor Drive Installation” (Engine with front-mounted propeller governor drives) procedure in Chapter 72-20.		
<p>NOTICE If a new or reconditioned camshaft is to be installed, install new tappet bodies. Refer to the “Camshaft Replacement Guidelines” section in the latest revision of Service Instruction No. SI-1011 for guidelines on replacing the camshaft when new tappets are installed in the engine.</p>		
Complete the “Camshaft Inspection” in Chapter 72-20.		
Complete the “Camshaft Assembly and Installation” procedure in Chapter 72-20.		
Measure the camshaft end play in the left crankcase half per the “Camshaft Installation” procedure in Chapter 72-20.	*Measurement:	
Measure the camshaft end play in the right crankcase half per the “Camshaft Installation” procedure in Chapter 72-20.	*Measurement:	
Measure the crankshaft bearing journals. Refer to the “Crankshaft Bearing Surface Inspection” section in Chapter 72-20.	*Measurement:	
<p>* Measurements must be within tolerances specified in the latest revision of the <i>Service Table of Limits - SSP-1776</i>.</p>		

Engine Assembly Checklist for IO-390-C Series Engines (Cont.)		
Item	Comments	Done
Complete the “Crankshaft Installation” procedure in Chapter 72-20.		
Measure the thrust face clearances between the crankshaft and crankcase per the “Crankshaft Installation” procedure in Chapter 72-20.	*Measurement:	
Measure the slinger clearance per the “Crankshaft Installation” procedure in Chapter 72-20.	*Measurement:	
Measure the crankshaft end play per the “Crankshaft Installation” procedure in Chapter 72-20.	*Measurement:	
* Measurements must be within tolerances specified in the latest revision of the <i>Service Table of Limits - SSP-1776</i> .		
Assemble the crankcase halves per the “Crankcase Assembly” procedure and follow the torque sequence in Chapter 72-20.		
Complete the “Crankshaft Oil Seal Installation” procedure in Chapter 72-20.		
Complete the “Crankshaft Idler Gear Installation” procedure in Chapter 72-20.		
Complete the “Crankshaft Endplay Clearance Check” in Chapter 72-20 (after the crankcase is assembled).		
Complete the “Fuel Pump Plunger Inspection” in Chapter 72-25.		
Complete the “Fuel Pump Plunger Installation” procedure in Chapter 72-25.		
Complete the “Oil Pump Installation” procedure in Chapter 72-25.		
Complete the “Accessory Housing Installation” procedure in Chapter 72-25.		
Complete either the “Oil Pressure Screen Housing Installation” procedure or the “Oil Filter Base Installation” procedure in Chapter 72-50.		
Complete the “Thermostatic Oil Cooler Bypass Valve Installation” procedure in Chapter 72-50.		
Complete the “Fuel Pump Installation” procedure in Chapter 73-10.		
Complete the “Vacuum Pump Driven Gear Installation” and “Vacuum Pump Installation” procedures in Chapter 72-60.		

Engine Assembly Checklist for IO-390-C Series Engines (Cont.)		
Item	Comments	Done
Complete the “Propeller Governor Drive Installation” (Engine with rear-mounted propeller governor drives) procedure in Chapter 72-60.		
Complete the “Oil Sump Installation” procedure in Chapter 72-50. Be sure to install a new oil sump gasket.		
Complete the “Piston Installation” procedure in Chapter 72-30 for all four pistons. Make sure new piston rings are installed on each piston.		
Complete the “Fin Stabilizer Installation” procedure in Appendix A on all cylinders.		
Complete the “Cylinder Installation” procedure in Chapter 72-30.		
(If necessary) complete the “Starter Ring Gear Replacement” procedure in Chapter 72-70.		
Install the starter ring gear support per the “Starter Ring Gear Support Installation” procedure in Chapter 72-70.		
Complete the “Oil Level Gage Tube and Assembly Installation” procedure in Chapter 72-50.		
Complete the “Intercylinder Baffle Installation” procedure in Chapter 72-30.		
Install a new oil drain tube at each cylinder head and at the crankcase per the “Oil Drain Tube Installation” procedure in Chapter 72-30.		
Complete the “Intake Pipe Installation” procedure in Chapter 72-80.		
Examine, set the gap, rotate, and install the spark plugs per procedures in Chapter 74-20.		
Complete the “Magneto Installation” procedure in Chapter 74-30.		
Complete the “Ignition Harness Installation” procedure in Chapter 74-20.		
Complete the “Propeller Governor Oil Line Installation (Engines with Rear-Mounted Propeller Governor Drives)” procedure in Chapter 72-50.		
Complete the “Fuel Manifold Installation” procedure in Chapter 73-10.		
Complete the “Fuel Injector Installation” procedure in Chapter 73-10.		

Engine Assembly Checklist for IO-390-C Series Engines (Cont.)		
Item	Comments	Done
Complete the “Injection Nozzle Installation” procedure in Chapter 73-10.		
Install new fuel lines and complete the “Fuel Line Installation” procedure in Chapter 73-10.		
Complete the “Starter Installation” procedure in Chapter 72-70.		
Complete the “Alternator and Bracket Installation” and “Alternator Belt Installation” procedures in Chapter 72-70.		
Install the engine in the airframe per instructions in the <i>IO-390-C Series Engine Installation and Operation Manual</i> and applicable Airframe Maintenance Manual.		
Complete the “Add Oil to the Engine” procedure in Chapter 12-10.		
Complete an “Operational Ground Check” per Chapter 72-00.		

This page intentionally left blank.

72-15- PROPELLER FLANGE BUSHING REPLACEMENT

1. Propeller Flange Bushing Removal

NOTICE: Designated bushings are installed in specified locations on the propeller in a specific indexed configuration.

- A. During removal of the bushings from the propeller flange (also known as the crankshaft flange), attach a removable non-adhesive label/tag on the bushing that identifies the correct bushing part number and location for reference on reassembly.
- B. Although the propeller flange bushing configuration is shown in the applicable Illustrated Parts Catalog, refer to the latest revision of Service Instruction No. 1098 for the latest part number and propeller flange bushing location (since an update of Service Instruction No. 1098 is more likely to occur before the parts catalog update.)
- C. Use the Propeller Flange Bushing Removal/Installation Tool ST-115 to remove each bushing from the propeller flange.

2. Propeller Flange Bushing Installation

 CAUTION: IF THE PROPELLER FLANGE BUSHING OF THE CORRECT PART NUMBER IS NOT INSTALLED IN THE SPECIFIED LOCATION, THE PROPELLER WILL NOT BE INDEXED CORRECTLY. EXCESSIVE PROPELLER BLADE STRESSES CAN OCCUR.

- A. As per the latest revisions of Service instruction No. SI-1098, identify the correct bushing part numbers for your engine and the location of each bushing.
- B. Use the Propeller Flange Bushing Removal/Installation Tool ST-115 to install the bushings of the correct part number on the propeller flange on the crankshaft in the location designated for your engine model specified in the latest revision of Service Instruction No. SI 1098.

This page intentionally left blank.

72-20 - RECIPROCATING ENGINE – CRANKCASE MAINTENANCE

1. Crankcase Inspection Before Disassembly

A. The crankcase inspection is done to:

- Identify any oil leaks, cracks, and mechanical damage on the crankcase
- Make sure that hardware fasteners are torqued correctly

⚠ WARNING: IF A DAMAGED OR CRACKED CRANKCASE IS NOT REPLACED, OIL CAN LEAK OUT OF THE CRANKCASE AND CAUSE ENGINE DAMAGE. DO NOT TRY TO WELD OR REPAIR A CRACKED CRANKCASE. REPLACE THE CRANKCASE.

- B. Examine the exterior surface of the crankcase per the Visual Inspection Checklist for IO-390-C Series Engines. Replace a damaged crankcase or a crankcase with one or more cracks.
- C. Complete a check of the torque on the crankcase hardware fasteners per the Standard Torque Tables in the latest revision of the *Service Table of Limits - SSP-1776*.
- D. Examine the crankcase breather for cracks, dents, and damage. If cracks, dents or damage are found, remove the engine as per Chapter 72-00 and send to Lycoming Engines.
- E. Examine the ends of the breather tube for scoring and out of roundness. If scoring or out-of-roundness is found, replace the breather tube,

NOTICE: In the next step, do not use a torque tool during the check for loose crankcase thru-bolts.

- F. Manually turn by hand each crankcase thru-bolt as a check for loose bolts. If the bolt can be manually turned, remove the bolt and examine the bolt for stripped threads. If the bolt threads are intact, install and torque the bolt in accordance with the Standard Torque Tables in the latest revision of the *Service Table of Limits - SSP-1776*.
- G. Replace any crankcase hardware fastener that is distorted or has stripped threads. Torque all hardware fasteners per the Standard Torque Tables in the latest revision of the *Service Table of Limits - SSP-1776* and in the correct sequence identified in this chapter.

2. Connecting Rod Removal

⚠ CAUTION: DO NOT RE-USE THE CONNECTING ROD BEARINGS, BOLTS, AND NUTS.

NOTICE: If the two nuts in the connecting rod cap cannot easily be removed, use a soft (plastic head) mallet and gently tap on the end of the two bolts to remove the nuts and the bolts.

- (1) Remove and discard the two nuts (Figure 1) and the two bolts that attach the connecting rod cap to the connecting rod.
- (2) Remove the connecting rod cap and connecting rod; keep them together, apply a label to identify the throw position of the connecting rod for reference on assembly.
- (3) Remove and discard the two connecting rod bearings.

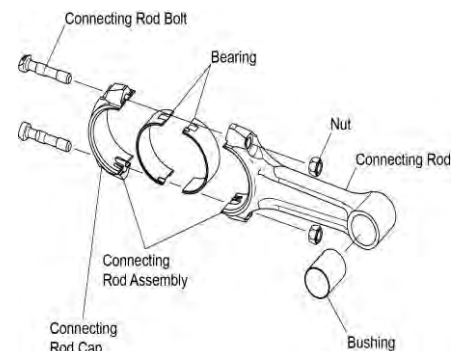


Figure 1
Connecting Rod Parts

3. Crankcase Disassembly

- A. Put the crankcase upright on a suitable work surface
- B. Crankshaft Idler Gear and Bushing Removal
 - (1) Remove the idler gears and bushings (Figure 2) from the idler gear shafts.
 - (2) Discard the bushings.

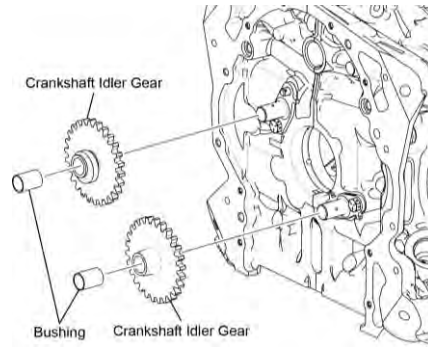


Figure 2
Crankshaft Idler Gears

⚠ CAUTION: TO PREVENT DAMAGE TO THE CRANKCASE, REMOVE ALL THRU-STUDS, NUTS, AND BOLTS FROM THE CRANKCASE HALVES BEFORE SEPARATION OF THE CRANKCASE HALVES.

- C. Use a slide hammer, a Crankcase Thru-Stud Puller ST-271 or Crankcase Thru Stud Driver ST-317 or a plastic hammer to remove the four thru-studs from the crankcase (Figure 3).
- D. Remove the remaining bolts and nuts that attach the crankcase halves.
- E. Insert one used pushrod into each of the four holes where the thru-studs were removed to support the camshaft and crankshaft when the crankcase halves are separated.

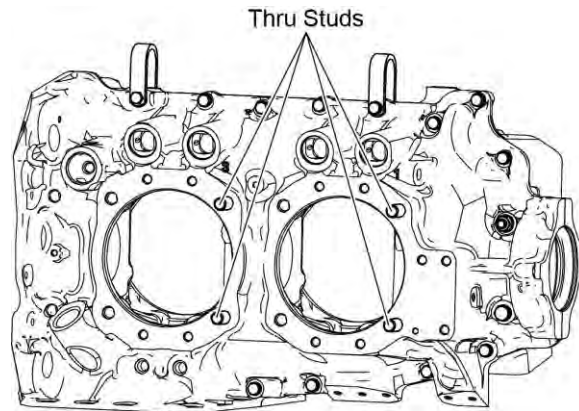


Figure 3
Crankcase Assembly

- F. Separate the crankcase with a Crankcase Separating Tool ST-389 or with a slide-hammer attached to one of the base studs as shown in Figures 4, 5, and 6.



Figure 4
Attach the Slide-Hammer to a Base Stud



Figure 5
Strike the Slide Part of the Tool Against the Back of the Tool



Figure 6
Separate the Crankcase Halves

- G. Remove the camshaft when the crankcase halves are separated enough to allow for removal (Figure 7).
- H. Remove the camshaft tachometer shaft, spacer, pin, and internal retaining ring. Discard the internal retaining ring, spacer, and pin.
- I. Continue separating the crankcase halves until the crankshaft can be removed from the crankcase (Figure 8).



Figure 7
Remove the Camshaft



Figure 8
Remove the Crankshaft

- J. Put the crankshaft in a suitable V-block-type fixture as shown in Figure 9.

NOTICE: Undersize crankshafts are identified by a code symbol stamped on the front of the flange as a suffix to the part number. In addition to the code symbols, the letters "RN" are stamped as a suffix to the crankshaft serial number, indicating that the crankshaft has been renitrided.

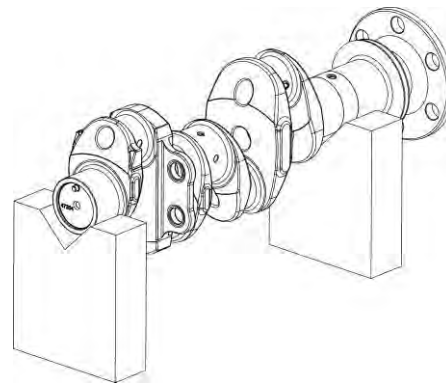


Figure 9
Crankshaft in V-Block-Type Fixture

- K. Tappet, Main Bearing and O-Ring Removal

(1) Remove the hydraulic tappet plungers using the Tappet Assembly Tool P/N 64941.

⚠ CAUTION: IF A TAPPET ASSEMBLY TOOL IS NOT AVAILABLE, REMOVE THE PUSH ROD SOCKETS BY HAND OR BY MAKING A LOOP FROM A SHORT LENGTH OF SAFETY WIRE. DO NOT USE A MAGNET TO REMOVE THE SOCKET OR THE PLUNGER ASSEMBLY FROM THE ENGINE, AS THIS COULD CAUSE THE BALL TO REMAIN OFF ITS SEAT AND MAKE THE UNIT INOPERATIVE.

(2) Remove the push rod socket (Figure 10) by placing heavy grease on the ball end of the Tappet Assembly Tool. Push the greased ball end of the Tappet Assembly Tool into the socket and withdraw it. The socket will adhere to the grease.

- (3) Push the hollow end of the Tappet Assembly Tool over the hydraulic tappet plunger and withdraw the plunger.
- (4) Bend a right angle in one end of a piece of wire and insert this end into the space between the plunger assembly and the tappet body. Turn the wire 90° to engage a coil of the spring and draw out the hydraulic tappet plunger assembly. Refer to Figure 11.

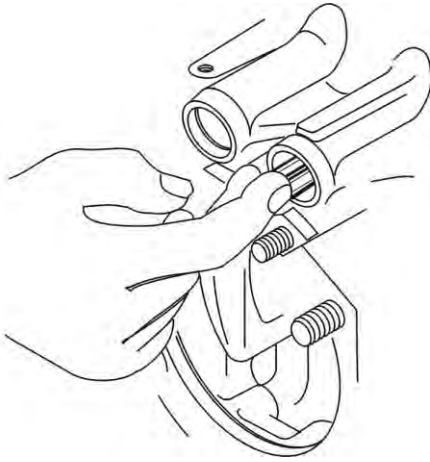


Figure 10
Removing Push Rod Socket

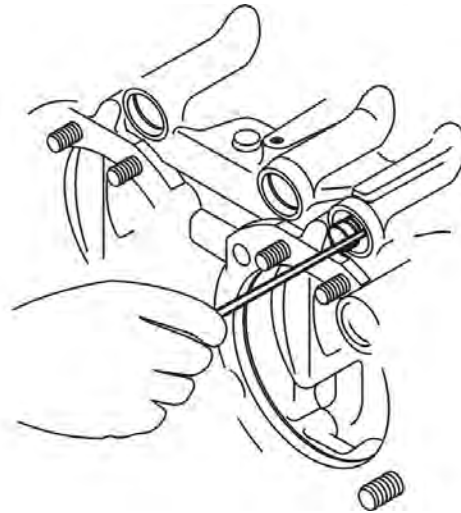


Figure 11
Removing Hydraulic Tappet Plunger Assembly

- (5) Remove and discard the crankshaft bearings, crankshaft front bearings, and O-rings (Figure 12).

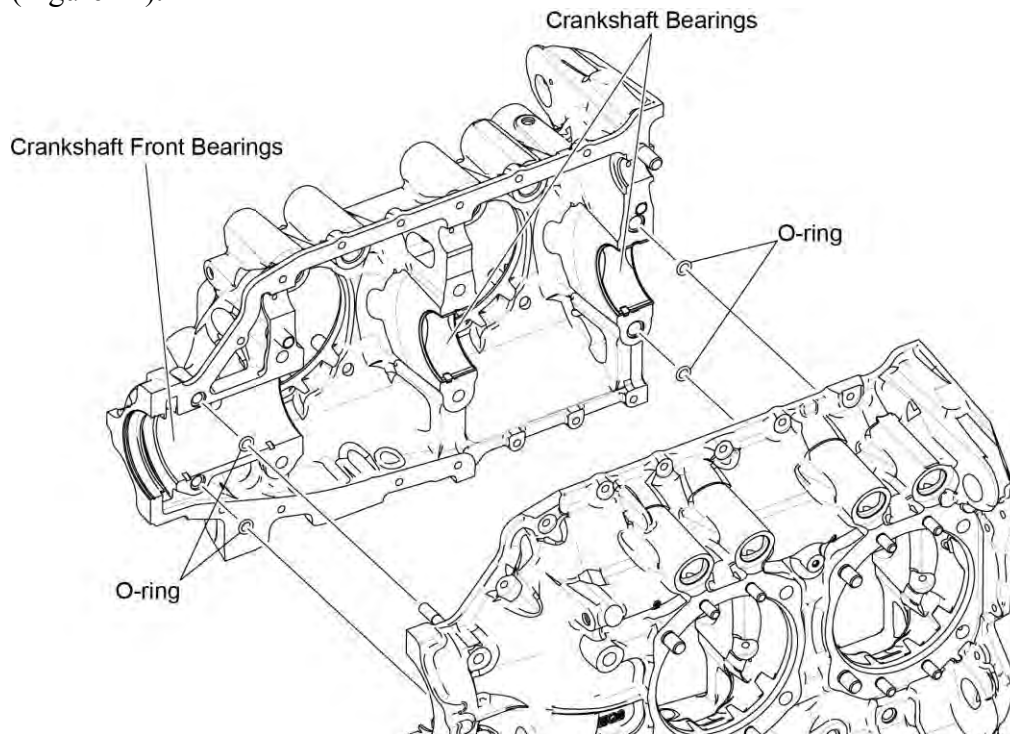


Figure 12
Main Bearings and O-Rings

L. Propeller Governor Drive Removal/Disassembly (Engines with Front-Mounted Propeller Governor Drives)

- (1) If not already done, remove the four nuts, lock washers and washers (Figure 13) from the front-mounted propeller governor or the propeller governor drive cover. Discard the lock washers.
- (2) Remove the propeller governor or the propeller governor drive cover and governor gasket. Discard the governor gasket.
- (3) Cut and remove the safety wire/cable from the idler gear shaft plug (Figure 13).
- (4) Remove the idler gear shaft plug and gasket from the crankcase (Figure 13). Discard the gasket.

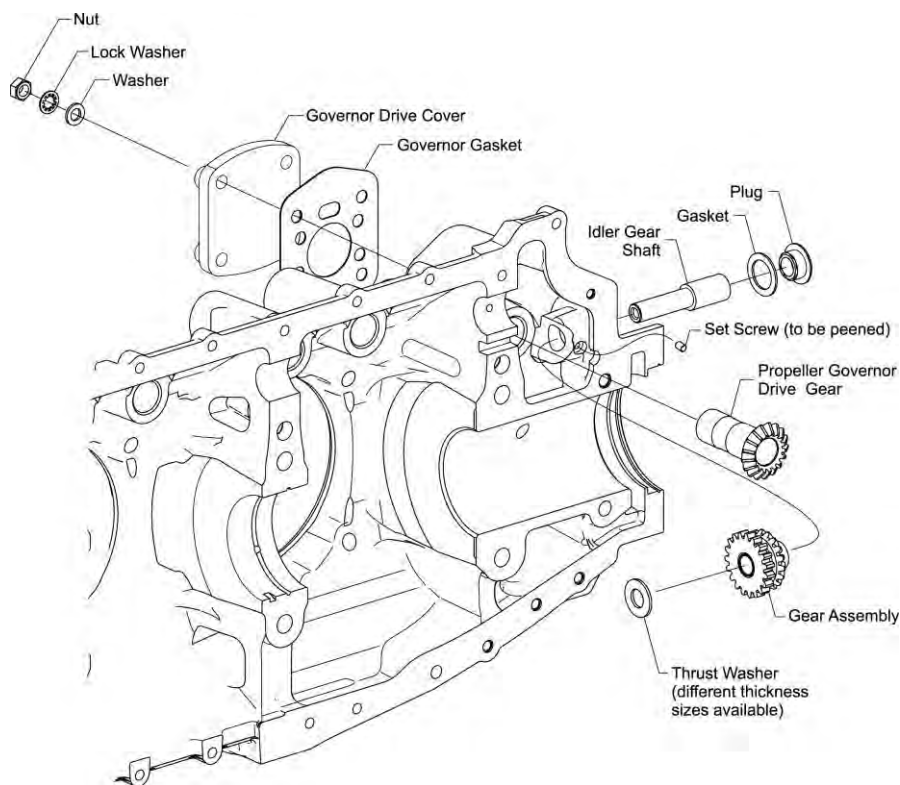


Figure 13
Propeller Governor Drive

- (5) Remove and discard the set screw from the propeller governor idler gear shaft. If the set screw was peened or staked in the hole, remove any debris.
- (6) Support the propeller governor idler gear shaft assembly and, at the same time remove the idler gear shaft, gear assembly, and thrust washer. Discard the thrust washer.

NOTICE: Do not remove the dowels or bushings from the gear assembly. If any part of the gear assembly is damaged, replace the entire gear assembly.

- (7) Pull the propeller governor drive gear away from the crankcase.

M. Oil Plug Removal

Remove the threaded NPT plugs from the accessory housing, oil sump, and crankcase to facilitate cleaning (Figures 14, 15, and 16).

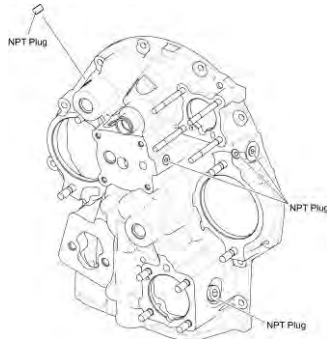


Figure 14
Oil Plugs in the Accessory Housing

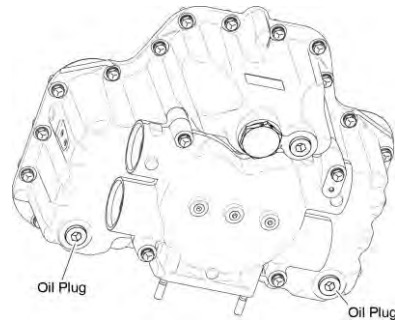


Figure 15
Oil Plugs in the Oil Sump

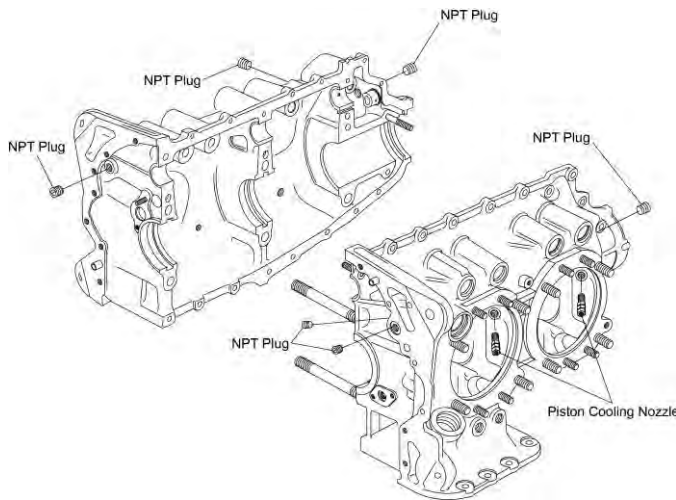


Figure 16
Oil Plugs in the Crankcase

N. Crankshaft Idler Gear Shaft Removal

- (1) Remove the safety wire (Figure 17) from the nut and three bolts that attach the crankshaft idler gear shafts to the crankcase halves.
- (2) Remove the nut and three bolts (Figure 18) that attach the crankshaft idler gear shafts to the crankcase halves.
- (3) Remove the two idler gear shafts from the rear of the crankcase halves (Figure 18).

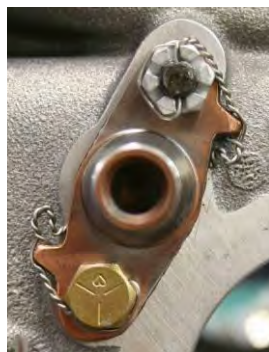


Figure 17
Safety Wire on the Idler Gear Shaft

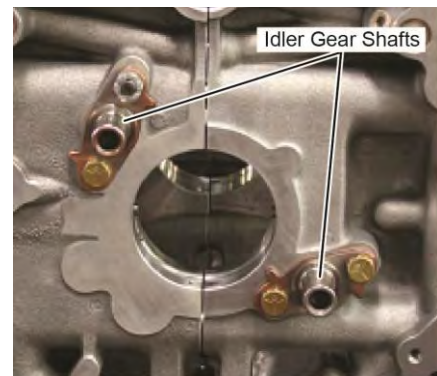


Figure 18
Crankshaft Idler Gear Shafts

O. Piston Cooling Nozzle Removal

Remove the four piston cooling oil nozzles from the crankcase (Figure 19).

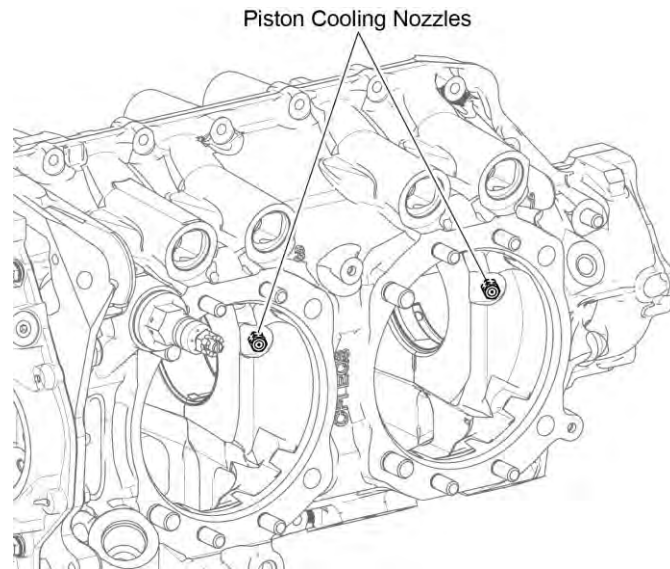


Figure 19
Piston Cooling Nozzles

4. Crankshaft Disassembly

⚠ WARNING: USE CARE WHEN HANDLING THE CRANKSHAFT AND ITS PARTS – DO NOT ETCH OR MAKE MARKS ON THE CRANKSHAFT OR COUNTERWEIGHTS. AN ETCH OR A MARK CAN CAUSE WEAKNESS AND FATIGUE IN THE CRANKSHAFT, WHICH COULD CAUSE CRANKSHAFT FAILURE.

- A. Bend the tabs of the crankshaft gear bolt lockplate down, flat against the crankshaft gear.
- B. Remove the crankshaft gear bolt, lockplate, and crankshaft gear from the crankshaft (Figure 20). Discard the bolt and the lockplate.

NOTICE: Any time the crankshaft gear bolt (Figure 20) is removed from the crankshaft, discard this bolt and replace it with a new bolt during assembly.

Do not remove the alignment dowel (Figure 20) from the end of the crankshaft unless it is damaged. Replace a damaged alignment dowel per the “Alignment Dowel Replacement” procedure in this chapter.

Do not remove the propeller flange bushings unless they are loose or damaged (Chapter 72-15).

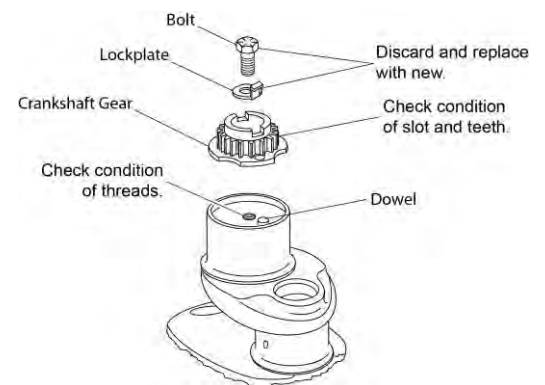


Figure 20
Crankshaft Gear and Associate Parts

NOTICE: Skip the next step if a constant speed propeller is used because an expansion plug is not installed in the crankshaft.

CAUTION: DO NOT DRILL THE EXPANSION PLUG OR USE A MAGNET TO REMOVE THE PLUG OR ANY LITTLE PIECES OF PLUG REMNANTS.

C. If installed, remove the larger expansion plug and inner plug (Figure 21) from the crankshaft by punching a 1/8 in. (3.175 mm) to 3/16 in. (4.763 mm) hole in the center of the plug. Use a hook or bent rod to pull out the plug. Remove any little pieces of plug remnants. Discard the expansion plug and inner plug.

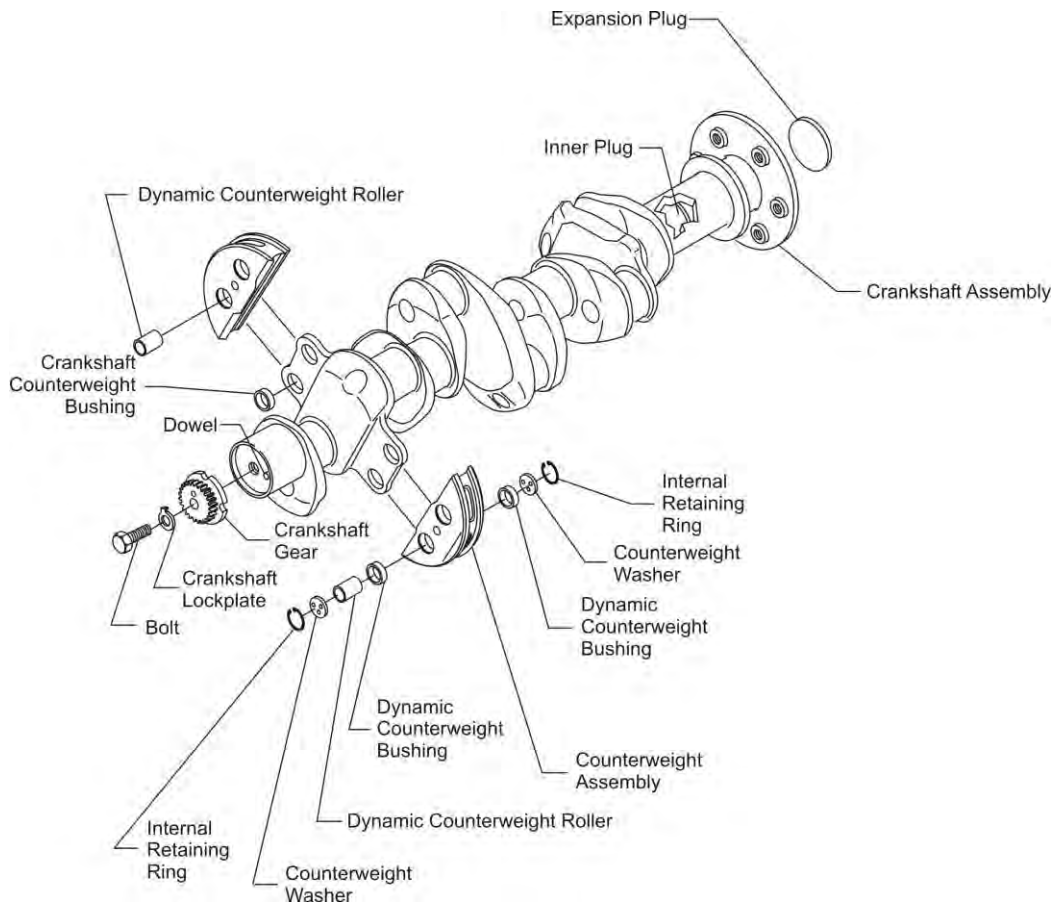


Figure 21
Crankshaft and Counterweight Assembly

CAUTION: WHEN TOUCHING COUNTERWEIGHTS AND ROLLERS DO NOT MAKE SCORES, SCRATCHES, OR ETCH MARKINGS OF ANY KIND ON THE CRANKSHAFT AND ROLLERS. A MARK IN ANY OF THESE AREAS CAN CAUSE THE PART TO WEAKEN AND POSSIBLY FAIL.

NOTICE: Counterweights (Figure 22) of a specific order are installed in specified locations identified in the latest revision of Service Instruction No. SI-1012.

During counterweight removal, identify the counterweight and its location on a non-adhesive label and temporarily apply this label to the counterweight for reference on reassembly.

D. Counterweight Removal

- (1) Remove each counterweight from the crankshaft. Apply the non-adhesive label to identify the location and position on the crankshaft for reference on reassembly

NOTICE: Since every counterweight has a matched pair of rollers that must stay with each counterweight, make another non-adhesive label to identify the roller pair that goes with each counterweight. Apply the label to the roller pair during removal to prevent mixing the roller pairs on different counterweights during reassembly.

- (2) Remove the two retaining rings (or circlips), two washers, and matched roller pair (Figure 22) from each counterweight. Discard the retaining rings and washers regardless of condition.

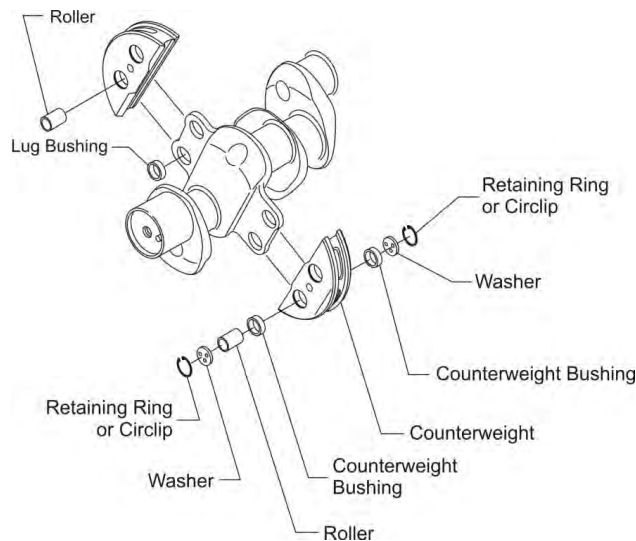


Figure 22

Counterweight, Rollers, Counterweight Bushings, and Lug Bushings

CAUTION: COUNTERWEIGHT BUSHINGS MUST ALWAYS BE REPLACED WITH NEW COUNTERWEIGHT BUSHINGS WHENEVER THESE BUSHINGS ARE REMOVED. DAMAGE OR WEAR ON THE CRANKSHAFT COUNTERWEIGHT BUSHINGS COULD CAUSE FAILURE OF THE COUNTERWEIGHT AND/OR THE CRANKSHAFT.

NOTICE: All counterweight bushings on all of the counterweights must be replaced at the same time.

- (3) Remove the counterweight bushings in the steps below.

Tools to be used include:

- Arbor Press Spindle
- Counterweight Bushing Driver ST-92
- Counterweight Fixture Assembly ST-93
- Depth Control Spacer ST-93-3
- Depth Control Spacer ST-93-5

(a) Put the counterweight flat on the table, square and level against the Arbor Press Spindle.

(b) Install the applicable Depth Control Spacer ST-93-3 or ST-93-5 (Figure 23) in the counterweight bushing bore.

- (c) Use the Arbor Press Spindle and Counterweight Bushing Driver ST-92 to press both bushings out from one side of the counterweight. Refer to Figure 23.
- (d) Turn the counterweight over.
- (e) Use the Arbor Press Spindle and Counterweight Bushing Driver ST-92 to press out the remaining bushings.

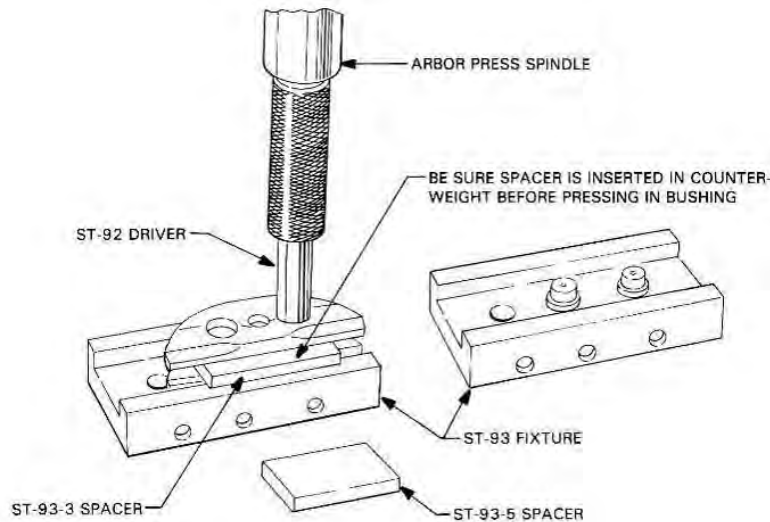


Figure 23
Counterweight Bushing Removal/Installation
Using the Counterweight Fixture Assembly ST-93
and the Counterweight Bushing Driver ST-92

5. Crankcase Dimensional Inspection

The crankcase dimensional inspection is done to make sure that the crankshaft bearings and camshaft slots formed by the crankcase are within allowable limits.

Complete the crankcase dimensional inspection as follows:

- A. Install new crankshaft bearings at all main bearing locations in the crankcase halves (Figure 12).
- B. Assemble the crankcase halves and install thru-studs (Figure 3).
- C. Use washers and nuts on the thru-studs to install the Torque Hold Down Plates (ST-222, Figure 83) at the cylinder pads over the thru-studs. Tighten the nuts only finger tight at this time.
 - (1) Make sure that the plates remain parallel with the cylinder decks of the crankcase.
 - (2) Temporarily torque the nuts to 300 in.-lb. (34 Nm).
- D. Attempt to insert a 0.004 in. tapered feeler gage between the crankcase mating faces. If the gage will not enter between the crankcase parting faces, the crankcase is considered satisfactory.
- E. Make a copy and complete the Crankcase Dimensional Inspection Checklist for IO-390-C Series Engines.
- F. Remove the nuts, washers, and Torque Hold Down Plates (ST-222), and separate the crankcase halves.

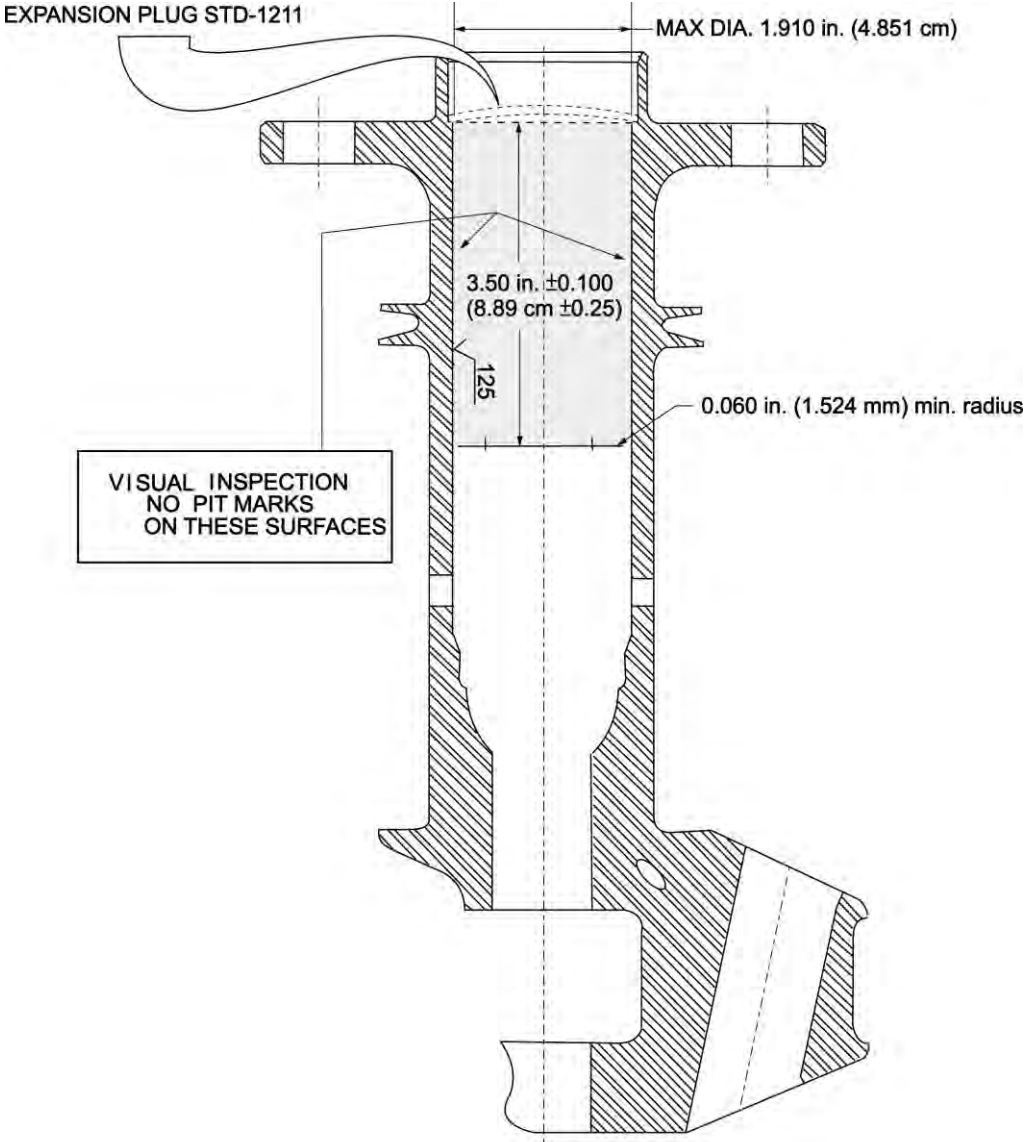
Crankcase Dimensional Inspection Checklist for IO-390-C Series Engines			
Engine Model Number _____ Engine Serial Number: _____			
Engine Time: _____ Date Inspection Done: _____			
Inspection done by: _____			
Item	Comments	Findings/ Corrective Action	Done
Measure the I.D. of the crankshaft bearings installed in the crankcase.		Center main bearing measurement _____ inches Rear main bearing measurement _____ inches	
Measure the O.D. of the crankshaft at the center and rear bearing locations.		Crankshaft at center main bearing measurement _____ inches Crankshaft at rear main bearing measurement _____ inches	
Measure the I.D. of the camshaft slots formed by the crankcase when assembled (Figure 72).		Front camshaft slot measurement _____ inches Center camshaft slot measurement _____ inches Rear camshaft slot measurement _____ inches	
Measure the O.D. of the camshaft at the camshaft slot locations.		Front camshaft slot location measurement _____ inches Center camshaft slot location measurement _____ inches Rear camshaft slot location measurement _____ inches	
Compare the difference between each crankshaft bearing I.D. and crankshaft O.D. measurement and the difference between each camshaft slot I.D. and camshaft O.D. measurement to the allowable clearance in the latest revision of the <i>Service Table of Limits - SSP-1776</i> .			

6. Crankshaft Inspection

- A. Before cleaning the crankshaft, initially examine the crankshaft gear and crankshaft inner diameter and external surface for evidence of pitting and wear. These conditions are of particular importance when they occur on the involutes of the crankshaft gear teeth. Replace the crankshaft gear if there is any pitting or wear.
- B. Clean the crankshaft per “Crankshaft Cleaning” and “Crankshaft Counterbore Cleaning” procedures in Chapter 05-30. Prior to inspection, the crankshaft counterbore must be clean, dry, and free of debris. Make a copy of the Crankshaft Inspection Checklist to record the condition of the crankshaft and any corrective action.
- C. Continue with the crankshaft inspection. Do not make scores, scratches, or etch markings of any kind on the crankshaft. A mark in any of these areas can cause the crankshaft to weaken and to possibly fail.

Crankshaft Inspection Checklist for IO-390-C Series Engines			
Engine Model Number _____		Engine Serial Number: _____	
Engine Time: _____		Date Inspection Done: _____	
Inspection done by: _____			
Item	Comments	Findings/ Corrective Action	Done
Carefully examine all surfaces of the crankshaft for cracks, gouges, nicks, dents, or damage.	If a crack is found, replace the crankshaft. <u>Do NOT try to repair a cracked or damaged crankshaft.</u>	Acceptable Replace	
Complete a magnetic particle inspection on the crankshaft.	Refer to the “Non-Destructive Testing” section in Chapter 05-50.	Acceptable Replace	
Use a flashlight, magnifying glass, and angled inspection mirror to visually examine the inner diameter of the crankshaft bore (Figure 24), starting at the crankshaft flange end. Look for pit marks and corrosion. "Pitting" looks like holes, cracks, or fissures of unspecified depth or direction.	If corrosion is found, replace the crankshaft. If pitting is found, complete a Fluorescent Penetrant Inspection (FPI) (per the section "Non-Destructive Testing" in Chapter 05-50).	Acceptable Replace	
Measure the inner diameter of the crankshaft. Record the measurement. Refer to Figure 24.	For a crankshaft to be acceptable, the inner diameter must not be more than 1.910 in. (4.851 cm). If the inner diameter of the crankshaft is more than 1.910 in. (4.851 cm), replace the crankshaft.	Inner diameter measurement: _____ inches or _____ centimeters	

Crankshaft Inspection Checklist for IO-390-C Series Engines (Cont.)

Item	Comments	Findings/ Corrective Action	Done
 <p style="text-align: center;">Figure 24 Area to be Examined</p>			
<p>Examine the crankshaft bearing surfaces.</p>	<p>Refer to the “Crankshaft Bearing Surface Inspection” section in this chapter.</p>		
<p>Examine the counter-bored mounting surface of the crankshaft for galling or fretting.</p>	<p>If galling or fretting is found, replace the crankshaft.</p>		

Crankshaft Inspection Checklist for IO-390-C Series Engines (Cont.)

⚠ CAUTION: LYCOMING ENGINES NO LONGER APPROVES STRAIGHTENING OR GRINDING OF BENT CRANKSHAFT FLANGES TO RESTORE MAXIMUM RUN-OUT. IF THE CRANKSHAFT FLANGE IS BENT, REPLACE THE CRANKSHAFT. DO NOT TRY TO STRAIGHTEN OR GRIND THE CRANKSHAFT FLANGE. (REFER TO THE LATEST REVISION OF SERVICE BULLETIN NO. SB-201)

Item	Comments	Findings/ Corrective Action	Done
Measure the crankshaft flange thickness and compare it with the dimensions below to calculate the minimum permissible thickness.	If the crankshaft flange is bent, replace the crankshaft. Do NOT straighten or grind a bent crankshaft. Refer to the latest revision of Service Bulletin No. 201 for any additional details.		
Crankshaft Flange Thickness			
Inches	Millimeters	Inches	Millimeters
0.440 ± 0.010	11.176 ± 0.254	0.420	10.668
Measure the run-out of the crankshaft flange with a dial indicator at the location shown in Figures 25 and 26. The maximum Total Indicator Reading (TIR) must not be more than 0.005 in. (0.127 mm). As shown in Figure 25, make sure that the pilot diameter runs true with the front and rear main bearings within 0.003 in. (0.076 mm).	If run-out exceeds 0.002 in. (0.051 mm) total indicator reading, replace the crankshaft. Do not try to repair or grind a warped or bent crankshaft flange.		

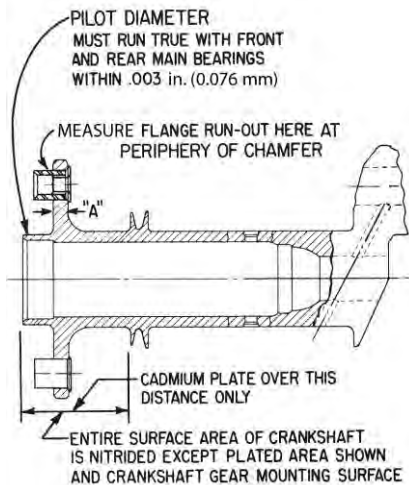


Figure 25
Crankshaft Flange

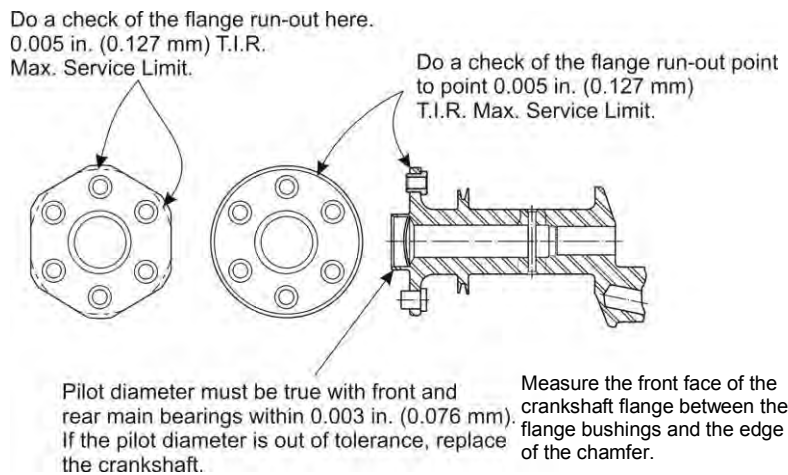


Figure 26
Crankshaft Flange Run-out and Pilot Diameter

Crankshaft Inspection Checklist for IO-390-C Series Engines (Cont.)

Crankshaft Gear Inspection

Any time the crankshaft gear bolt (Figure 27) and lockplate are removed from the crankshaft gear, the bolt and lockplate are to be discarded and replaced with a new bolt and new lockplate for the applicable crankshaft gear. The discarded bolt and lockplate are not to be re-installed on any engine.

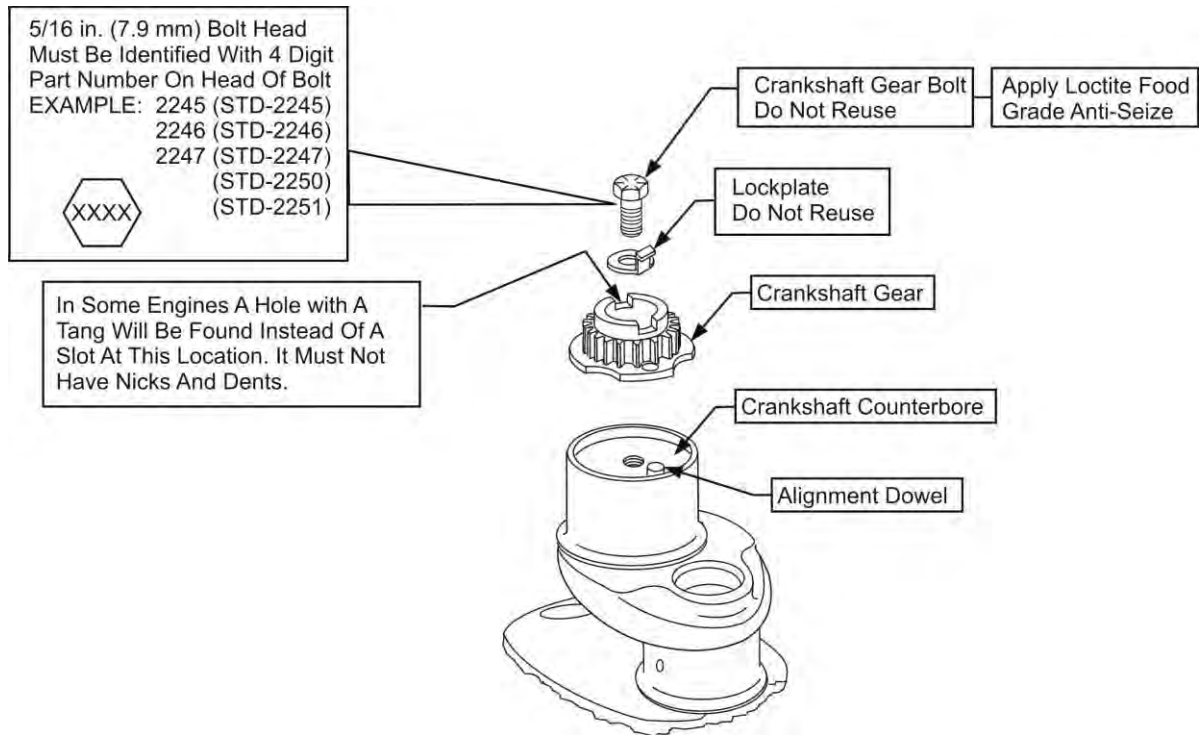
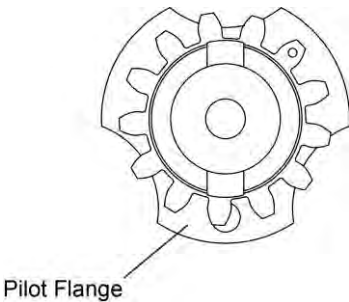


Figure 27
Crankshaft Gear Bolt and Lockplate

Item	Comments	Findings/ Corrective Action	Done
 <p>Figure 28 Pilot Flange</p>	<p>The crankshaft gear has three scallops as shown in Figure 28.</p>		

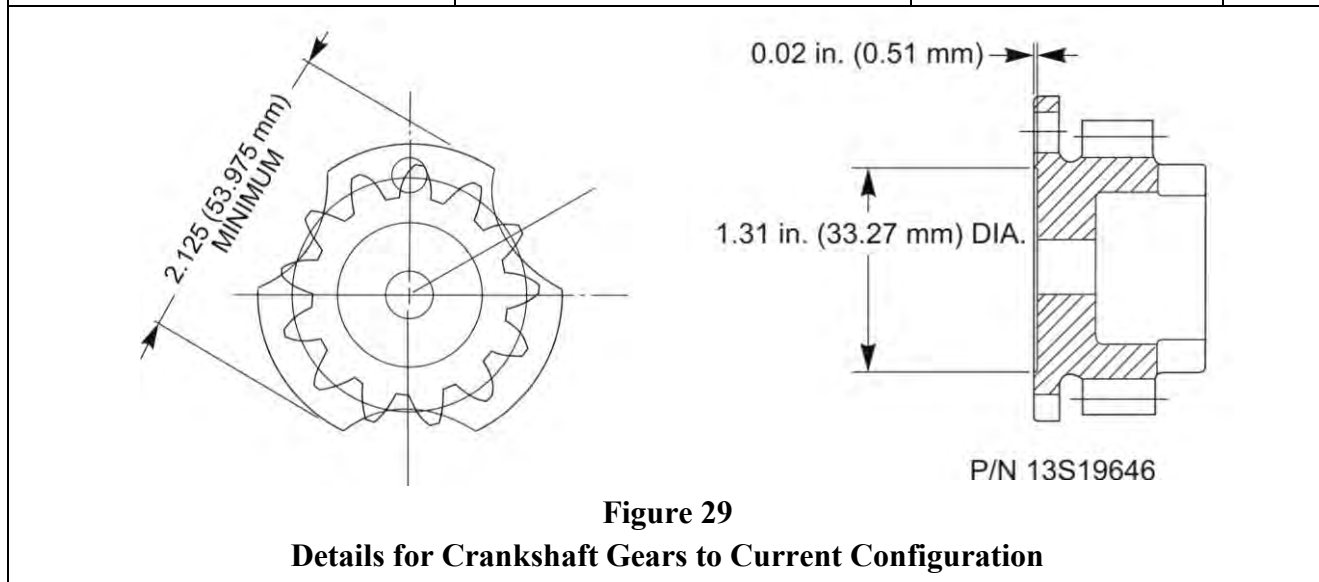
Crankshaft Inspection Checklist for IO-390-C Series Engines (Cont.)

Item	Comments	Findings/ Corrective Action	Done
------	----------	--------------------------------	------

Crankshaft Gear Inspection (Cont.)

Measure the diameter of the pilot flange of the crankshaft gear (Figure 29).	If the diameter of the pilot flange is less than 2.125 in. (53.975 mm) do not install this gear on the crankshaft. Replace the crankshaft gear with a serviceable crankshaft gear.		
--	--	--	--

Measure dimensions on the crankshaft gear per those shown in Figure 29 for the respective crankshaft gear part number.		Acceptable Replace	
--	--	-----------------------	--



Examine the crankshaft gear for pitting and wear.	Replace a pitted or worn crankshaft gear.	Acceptable Replace	
Examine the pilot flange diameter of the crankshaft gear for damage from galling or fretting.	If the pilot flange of the crankshaft gear is damaged, replace the crankshaft gear.	Acceptable Replace	
If there is a hole or slot on the crankshaft gear, examine the slot for any nicks or dents.	If nicks or dents are found, replace the crankshaft gear.	Acceptable Replace	
Complete a magnetic particle inspection of the crankshaft gear.	Refer to the “Non-Destructive Testing” section in Chapter 05-50.	Acceptable Replace	

Crankshaft Inspection Checklist for IO-390-C Series Engines (Cont.)			
Item	Comments	Findings/ Corrective Action	Done
Criteria for Crankshaft Gear Replacement			
<p>Lycoming Engines no longer approves rework or repair of an unacceptable crankshaft gear. Replace the crankshaft gear with a serviceable crankshaft gear if any of the following are found during the crankshaft gear identification and inspection.</p> <ul style="list-style-type: none"> • If the pilot flange diameter is less than 2.125 in. (53.975 mm) or is not in compliance with dimensions shown in Figure 29 • If the crankshaft gear does not have the larger scallops as shown in Figure 28 (the larger scallops enable the shim check) • Damaged counterbore face of the crankshaft gear • If the crankshaft gear has a hole or slot and there are any nicks or dents on the hole or slot • Nicks or deformities on the slot and teeth of the crankshaft gear • Pitting or wear • Crankshaft gear that fails magnetic particle inspection • Clearance between the mating surfaces of the crankshaft gear and crankshaft counterbore (There must not be any clearance when the crankshaft gear is installed.) 			
Crankshaft Counterbore Inspection			
<p>⚠ CAUTION: DO NOT TRY TO REPAIR THE CRANKSHAFT COUNTERBORE THREADS IN THE FIELD. IF THIS TYPE OF REPAIR IS NECESSARY, IT IS RECOMMENDED THE CRANKSHAFT BE SENT TO THE FACTORY (THROUGH AN AUTHORIZED LYCOMING DISTRIBUTOR) WITH PAPERWORK THAT IDENTIFIES THE NECESSARY REPAIR.</p> <p>NOTICE: Prior to inspection, the crankshaft counterbore must be clean, dry, and free of debris. Refer to the “Crankshaft Counterbore Cleaning” procedure in Chapter 05-30.</p>			
Make sure the threads in the counterbored end of the crankshaft are intact and not galled, stripped, or damaged.	If the threads are galled, stripped or damaged, it is recommended the crankshaft be sent to Lycoming Engines (through an authorized Lycoming distributor) with paperwork that identifies the type of damage. Do not try to repair the threads in the field.		
Measure the Inside Diameter (ID) of the crankshaft counterbore at the rear of the crankshaft to make sure there is a correct fit between the ID of the crankshaft and the Outside Diameter (OD) of the crankshaft gear pilot flange. The crankshaft counterbore diameter at the rear of the crankshaft must not be more than 2.126 in. (54.000 mm) when measured at any location.	If the diameter is oversized, replace the crankshaft. Lycoming Engines no longer approves rework or repair of an unacceptable crankshaft counterbore diameter.		

Crankshaft Inspection Checklist for IO-390-C Series Engines (Cont.)			
Item	Comments	Findings/ Corrective Action	Done
Examine the gear mounting face of the crankshaft counterbore.	If the mounting face of the crankshaft counterbore is damaged, replace the crankshaft.		
If there is a hole or tang on the crankshaft gear (instead of a slot), examine the tang for any nicks or dents.	If nicks or dents are found, replace the crankshaft gear with a new three-scallop pilot flange gear (Figure 28).		
Examine and measure the alignment dowel per instructions in the "Alignment Dowel Inspection" in this chapter.			

Counterweight Inspection

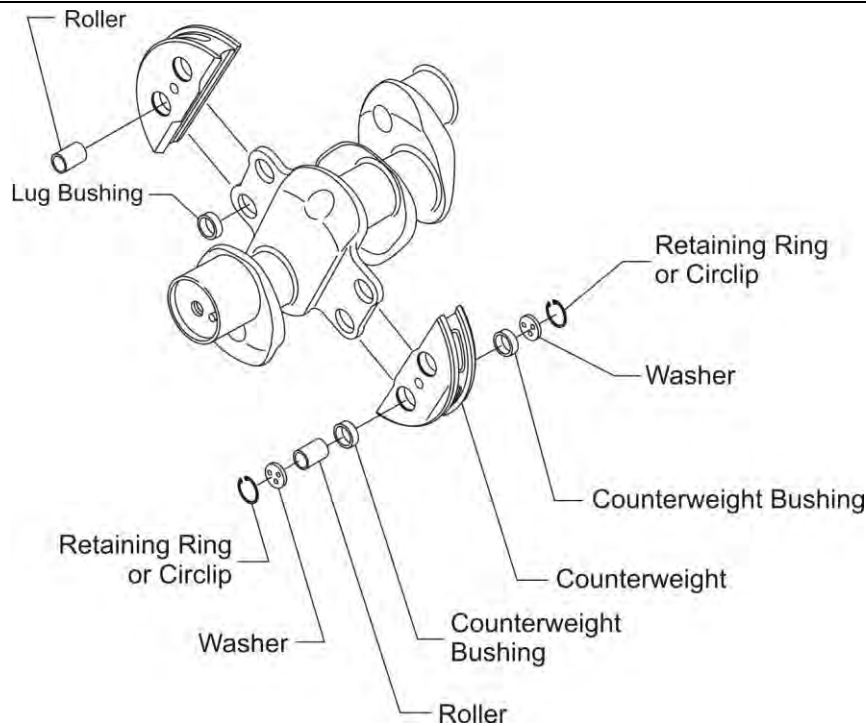


Figure 30
Crankshaft Counterweight, Rollers, and Bushings

NOTICE: A crankshaft counterweight (Figure 30) cannot be repaired. It only can be replaced.*
A counterweight roller cannot be repaired. It only can be replaced as an identical paired set specific for each counterweight.*

*Refer to the latest revision of Service Instruction Nos. SI-1012 and SI-1535 for part numbers and instructions to replace counterweights and rollers.

Crankshaft Inspection Checklist for IO-390-C Series Engines (Cont.)			
Item	Comments	Findings/ Corrective Action	Done
Counterweight Inspection (Cont.)			
Examine the surface of the counterweight for scoring, scratches, punch marks, or any other surface damage. Make sure the counterweight surface is smooth.	Replace the counterweight if there is scoring, scratches, punch marks, or any other surface damage or if the counterweight surface is not smooth. If one or more cracks are found on the counterweight, replace the counterweight*.	Outcome of Counterweight Position 1 inspection: Accept Replace	
		Outcome of Counterweight Position 2 inspection: Accept Replace	
		Findings / Comments:	
Complete Non-Destructive Test (NDT) (magnetic particle inspection) on the counterweights.	Refer to Chapter 05-50.	Findings / Comments:	
Examine the bushing bore on the counterweight for roundness and for any scratches, etching, galling or any other surface damage. Measure the bushing bore diameter on the counterweight.	Replace the counterweight if the bushing bore on the counterweight is not round, not smooth, is out of tolerance, or has surface damage.*	Outcome of Bushing Bore Inspection for Counterweight Position 1 Accept Replace	
		Outcome of Bushing Bore Inspection for Counterweight Position 2 Accept Replace	
(a) If the counterweight has a letter B marking, the bushing bore diameter must be between 0.9384 and 0.9392 in. (23.8354 and 23.8557 mm). (b) If the counterweight does NOT have a letter B marking, the bushing bore on the counterweight is smaller and must be between 0.9369 and 0.9377 in. (23.7973 and 23.8176 mm).		Bushing Bore Diameter Counterweight Position 1:	
		Bushing Bore Diameter Counterweight Position 2:	
NOTICE: If the bushing bore on the counterweight is not within the specified tolerances, replace the counterweight. Some counterweights must be replaced as a matched set.*			
⚠ CAUTION: DO NOT INCREASE THE DIAMETER OF THE BUSHING BORE ON A COUNTERWEIGHT. THIS ENLARGEMENT CAN CAUSE ENGINE DAMAGE BECAUSE IT WILL DECREASE THE SNAP RING GROOVE DEPTH IN THE BUSHING BORE ON THE COUNTERWEIGHT.			
*Refer to the latest revision of Service Instruction Nos. SI-1012 and SI-1535 for part numbers and instructions to replace counterweights and rollers.			

Crankshaft Inspection Checklist for IO-390-C Series Engines (Cont.)			
Item	Comments	Findings/ Corrective Action	Done
Counterweight Inspection (Cont.)			
Examine the surface of the rollers for scoring, scratches, punch marks, or any other surface damage. Make sure the roller surface is smooth.	If the roller surface is not smooth or has scoring, scratches, punch marks, or any other surface damage is on one or both rollers in a pair, replace the rollers as a matched pair.	Outcome of Roller Pair Inspection for Counterweight Position 1 Accept Replace	
		Outcome of Roller Pair Inspection for Counterweight Position 2 Accept Replace	
		Findings / Comments:	
Complete NDT on rollers. Refer to Chapter 05-50.	If one or more cracks are found on a roller, replace the rollers as a matched pair.*	Findings / Comments:	
Measure the roller dimensions per the latest revision of Service Instruction No. SI-1535.	If the roller is out of tolerance, replace the rollers as a matched pair.*	Findings / Comments:	
*Refer to the latest revision of Service Instruction Nos. SI-1012 and SI-1535 for part numbers and instructions to replace counterweights and rollers.			
Criteria for a Serviceable Crankshaft			
A crankshaft is serviceable if it meets all of following conditions:			
<ul style="list-style-type: none"> • Measurements conform to all dimensional specifications • No pitting, no cracks • Pitting but no cracks 		<ul style="list-style-type: none"> • Crankshaft passes FPI (Refer to the checklist “Results of the Fluorescent Penetrant Inspection of Crankshaft” in this chapter. 	
Rejection Criteria for a Crankshaft			
A crankshaft must be replaced under any of the following conditions:			
<ul style="list-style-type: none"> • Measurements do not conform to all dimensional specifications • Corrosion 		<ul style="list-style-type: none"> • Crack(s) or pitting with crack(s) in the crankshaft inner bore • Crankshaft fails FPI 	
Findings/Comments:			

Results of Fluorescent Penetrant Inspection of Crankshaft		
Crankshaft P/N		Inspector
Crankshaft S/N		Date of Inspection
Black Light Inspection of Crankshaft Bore (inner diameter)		
Inspection Item	Guidelines and Corrective Action	Findings and Action Taken
Look for fatigue crack(s) or start of crack(s) in crankshaft bore Look for cracks caused by heat or brittleness	Start of cracks or crack(s) found - replace the crankshaft	Acceptable Replace
Look for inappropriate repair, such as grinding to remove corrosion, in or near crankshaft bore	Evidence of grinding - replace the crankshaft	Acceptable Replace
Look for ruptures inside the crankshaft bore	Rupture found - replace the crankshaft	Acceptable Replace
Additional check necessary?	Discontinuity found - replace the crankshaft	Acceptable Replace
Comments/Notes:		

7. Alignment Dowel Inspection

- A. Examine the alignment dowel installed in the end of the crankshaft.
- B. Make sure the alignment dowel is perfectly smooth and round, without nicks or deformation.
- C. Make sure that the shoulder of the dowel is 0.010 to 0.020 in. (0.25 to 0.51 mm) below the surface of the crankshaft as shown in Figure 31.
- D. Make sure the alignment dowel fits tightly in the crankshaft. It must not spin or be loose.

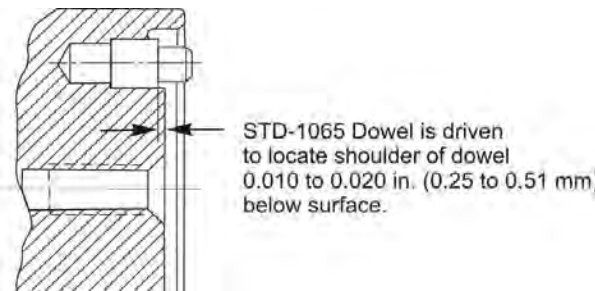


Figure 31

Section Through Counterbore End of Crankshaft Showing Driven Height of Dowel

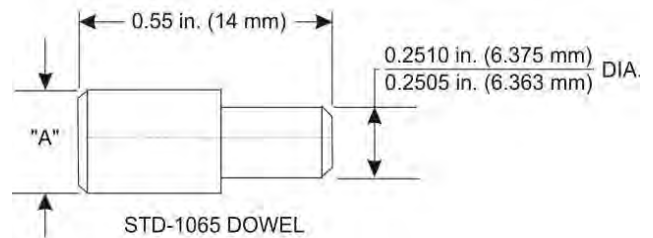


Figure 32

Details of Crankshaft Dowel

- E. Measure the diameter of the alignment dowel (Dimension A) shown in Figure 32 and determine if the measurement conforms to the values for the different alignment dowel part numbers in the latest revision of Service Bulletin No. SB-475 for additional details.
 - F. If the alignment dowel is out of tolerance or out of round, replace the dowel with a new one per the “Alignment Dowel Replacement” procedure in this chapter.
8. Crankshaft Bearing Surface Inspection
- A. Examine all bearing surfaces for scoring, galling, and wear.
 - B. Refer to the latest revision of *Service Table of Limits - SSP-1776* to identify the nominal manufactured specifications of the bearing journals. Undersize crankshaft bearing journals in Table 1 are identified by a code symbol stamped on the front of the flange as a suffix to the part number.

Table 1
Crankshaft Undersize Codes

Journals	0.003 in. (0.076 mm)	0.006 in. (0.152 mm)
Main Bearing Journals	M03M	M06M

- C. Using a micrometer, measure and record the dimensions.
- D. If the actual undersize is between the service limit (0.0015 in. and 0.003 in.), complete the following:
 - (1) Polish to 0.003 in. (0.076 mm) undersize.
 - (2) Fit with 0.003 in. (0.076 mm) bearing insert.
 - (3) Repeat for all bearings.

⚠ CAUTION: DURING POLISHING, DO NOT ALLOW THE LATHE SPEED TO EXCEED 150 RPM.

NOTICE: Polishing undersize is preferable to grinding undersize because shafts that are polished do not require re-nitriding.

If one bearing journal is polished to 0.003 in. or 0.006 in. undersize, all corresponding journals must be polished to the same size.
- E. If, after the bearing journal is polished to 0.003 in. (0.076 mm), the bearing journal requires more polishing complete the following:
 - (1) Polish to 0.006 in. (0.152 mm) undersize.
 - (2) Fit with 0.006 in. (0.152 mm) bearing insert.
 - (3) Repeat for all like bearings.
- F. If the actual undersize is greater than 0.006 in. (0.152 mm), replace the crankshaft.

9. Camshaft Inspection

There are two parts to the camshaft inspection: a visual inspection and a dimensional inspection.

Copy and complete the Camshaft Inspection Checklist to do the camshaft inspection.

NOTICE If a new or reconditioned camshaft is to be installed, install new tappet bodies. Refer to the “Camshaft Replacement Guidelines” section in the latest revision of Service Instruction No. SI-1011 for guidelines on replacing the camshaft when new tappets are installed in the engine.

If a hydraulic tappet body has been rejected for spalling, carefully examine the corresponding camshaft lobe for evidence of distress, surface irregularity, or feathering on the edges.

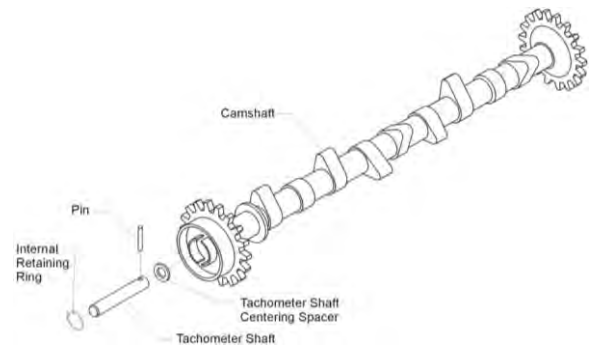
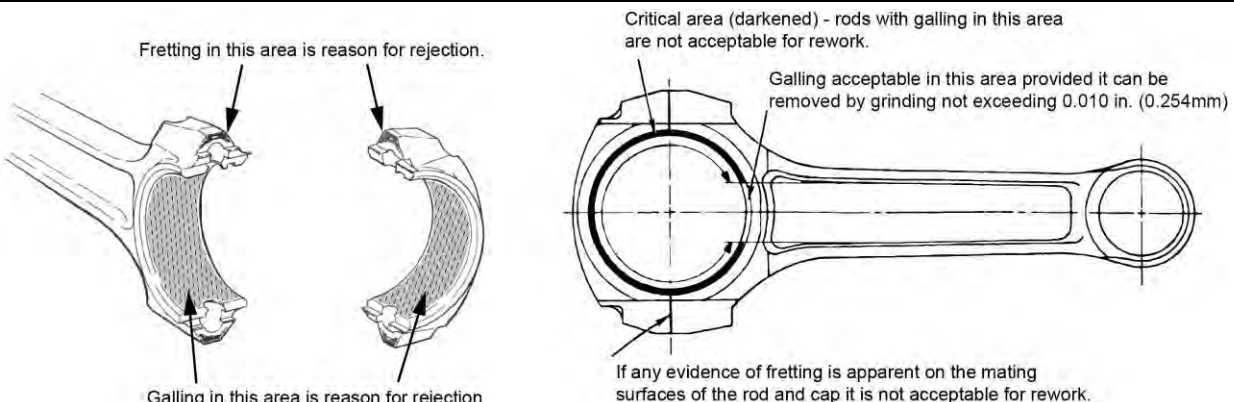


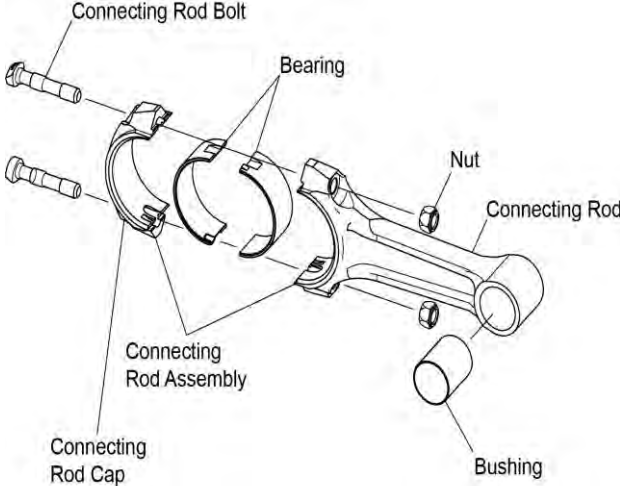
Figure 33
Camshaft with Integral Gears

Camshaft Inspection Checklist for IO-390-C Series Engines			
Item	Comments	Findings/ Corrective Action	Done
Camshaft Visual Inspection			
Visually examine all surfaces of the camshaft (Figure 33) – give particular attention to bearing surfaces and camshaft lobes. If any of the following conditions are found during this visual inspection, replace the camshaft: cracks, scoring, galling, corrosion, pitting, feathering (at edge of camshaft lobes or bearing), surface irregularity, distress/fatigue, or other damage			
Camshaft	Acceptable (No crack, scoring, galling, corrosion, pitting, feathering (at edge of camshaft lobes or bearing), surface irregularity, distress/fatigue, or other damage)		
	Replace Comment- condition(s) found:		
Camshaft Dimensional Inspection			
Support the camshaft in V-blocks and measure the run-out. For mounting locations and clearances, refer to the latest revision of the <i>Service Table of Limits - SSP-1776</i> . If the run-out is out of tolerance, replace the camshaft.	Run-out measurement:	Acceptable Replace	
Measure the OD of the camshaft at the bearing locations and compare the results to the bearings formed by the crankcase (per the “Crankcase Dimensional Inspection” in this chapter.) If the OD is not within limits, replace the camshaft.		Acceptable Replace	

10. Connecting Rod Inspection

Copy the Connecting Rod Inspection Checklist to record the condition of all of the connecting rods and any corrective action.

Connecting Rod Inspection Checklist for IO-390-C Series Engines				
Engine Model Number _____ Engine Serial Number: _____				
Engine Time: _____ Date Inspection Done: _____				
Inspection done by: _____				
Disassemble the connecting rod; clean the rod and its cap thoroughly. Visually examine the connecting rod for damage.				
Task or Inspection	Findings and/or Corrective Action			
	Cylinder 1	Cylinder 2	Cylinder 3	Cylinder 4
Examine the connecting rod bore for wear. If the rod bore is worn, replace the connecting rod assembly.	Acceptable Replace	Acceptable Replace	Acceptable Replace	Acceptable Replace
Examine the mating face of the connecting rod and its cap face for fretting (Figure 34). If fretting is found, replace the connecting rod assembly.	Acceptable Replace	Acceptable Replace	Acceptable Replace	Acceptable Replace
Use a 6 power magnifying glass (minimum) or bench microscope to examine the critical areas on the connecting rod identified in Figure 34 for galling.* If galling is found, replace the connecting rod assembly.	Acceptable Replace	Acceptable Replace	Acceptable Replace	Acceptable Replace
* Do not mistake stains or discoloration for galling. Surface blemishes are easily removed with a fine abrasive cloth, chemical cleaner or steel wool. Whereas, galling cannot be removed. If galling is found in the bearing bore, replace the connecting rod. If surface blemishes cannot be removed with a fine abrasive cloth, chemical cleaner or steel wool, there is evidence of galling. Gall marks vary in size and shape. Some gall marks can be as small as pin heads. Other gall marks can be circular, oval, or thin, or look like rods.				
				
Figure 34				
Areas on Connecting Rod to Examine for Fretting and Galling				

Connecting Rod Inspection Checklist for IO-390-C Series Engines (Cont.)					
Item	Comments	Findings/Corrective Action		Done	
Measure the Inner Diameter (ID) of the connecting rod bushing using a micrometer (Figure 35)	If the connecting rod bushing is worn beyond service limits per the latest revision of the <i>Service Table of Limits - SSP-1776</i> , replace the bushing.	Bushing ID Measurement			
		Connecting Rod 1			
		Connecting Rod 2			
		Connecting Rod 3			
		Connecting Rod 4			
 <p style="text-align: center;">Figure 35 Connecting Rod</p>	For connecting rods that pass the Visual Inspection herein, complete a Magnetic Particle Inspection on all connecting rods as per the “Non-Destructive Testing” section in Chapter 05-50.	Findings/ Corrective Action of Magnetic Particle Inspection		Done	
		Connecting Rod 1	Acceptable Replace		
		Connecting Rod 2	Acceptable Replace		
		Connecting Rod 3	Acceptable Replace		
		Connecting Rod 4	Acceptable Replace		
<p>Complete the “Connecting Rods - Parallelism / Squareness Check” in this chapter.</p> <p>Measure the distance between arbors (Figure 37). For exact parallelism or alignment, the distances measured on both sides are to be the same.</p> <p>Measure clearance at the points where the arbors rest on the parallel blocks (Figure 38) using a feeler gage. Compare the clearance between each arbor and the parallel blocks against the values in the latest revision of the <i>Service Table of Limits - SSP-1776</i>.</p>		Parallelism Measurement	Squareness Measurement		
	Connecting Rod 1				
	Connecting Rod 2				
	Connecting Rod 3				
	Connecting Rod 4				

Connecting Rod Inspection Checklist for IO-390-C Series Engines (Cont.)

Connecting Rod Bearing and Crankshaft Clearance

To complete this inspection:

NOTICE: For this inspection the connecting rods, bearings, connecting rod bolts, and nuts (Figure 35) are assembled, but not installed on the crankshaft.

1. Assemble and torque each connecting rod with acceptable bearings per instructions in the “Connecting Rod Installation” section in this chapter.
2. Measure the inside diameter of the bearing in each connecting rod and record the measurement below.
3. Measure the crankshaft diameter at the crankpin journal for each connecting rod and record the measurement below.
4. Subtract the crankshaft diameter at the crankpin journal from the inside diameter of the bearings for each connecting rod to calculate the connecting rod bearing and crankshaft clearance. Record the measurement below.
5. Compare the connecting rod bearing and crankshaft clearance to the acceptable clearance measurement in the latest revision of the *Service Table of Limits - SSP-1776*.
6. Remove and discard the connecting rod bolts and nuts from the connecting rod assembly.
7. If the connecting rod bearing and crankshaft clearance is within limits, the connecting rod bearings are acceptable.
8. If the connecting rod bearing and crankshaft clearance is not within limits, the connecting rod bearings must be replaced with oversize bearings to bring the clearance within acceptable limits.

Cylinder	Inside Diameter of the Bearings	Crankshaft Diameter at the Crankpin Journal	Connecting Rod Bearing and Crankshaft Clearance
Cylinder 1			
Cylinder 2			
Cylinder 3			
Cylinder 4			

11. Connecting Rods - Parallelism/Squareness Check

NOTICE: The Connecting Rod Parallelism and Squareness Gage P/N 64530 (Figure 36) is necessary for this check.

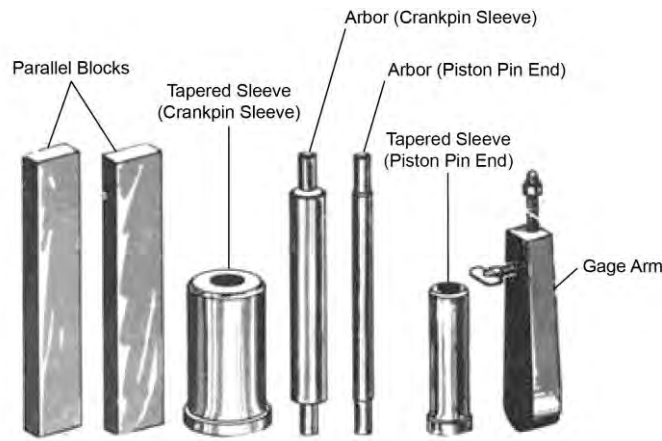


Figure 36
Connecting Rod Parallelism and Squareness Gage P/N 64530

- A. Make sure that the bearing cap is assembled correctly and is tightened securely.
- B. Insert the tapered sleeves (Figure 37) of the Connecting Rod Parallelism and Squareness Gage P/N 64530 in the bearing holes in the connecting rod.
- C. Pull the arbors through the sleeves.
- D. Install the gage arm on the arbor as shown in Figure 37.
- E. Turn the adjusting screw on the gage arm until it just touches the arbor.
- F. Use the wing nut to lock the adjusting screw.
- G. Make sure the adjusting screw just touches the arbor.
- H. Remove the gage arm and install it on the other end of the arbor.
- I. Measure the distance between arbors. For exact parallelism or alignment, the distances measured on both sides must be the same. Record the measurement in the Connecting Rod Inspection Checklist earlier in this chapter.
- J. Remove the gage arm.
- K. Keep the sleeves and arbors in place.
- L. Put the parallel blocks (Figure 38) of the Connecting Rod Parallelism and Squareness Gage on the surface plate.

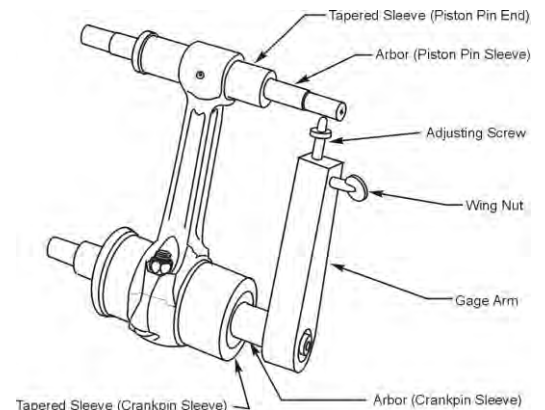


Figure 37
Parallelism Check of Connecting Rods

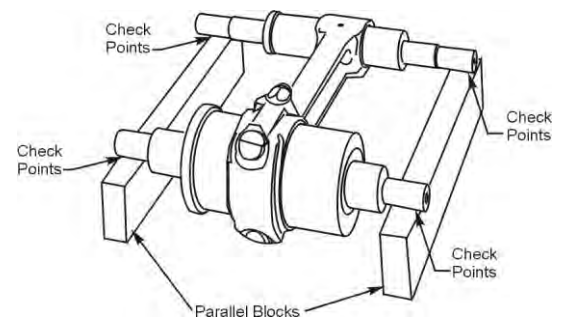


Figure 38
Squareness Check of Connecting Rods

- M. Put the ends of the arbors on the parallel blocks.
- N. For the squareness check, measure the clearance at the four check points in Figure 38 where the arbors rest on the parallel blocks using a feeler gage. Record the measurement in the Connecting Rod Inspection Checklist earlier in this chapter
- O. Compare the clearance between each arbor and the parallel blocks against the values in the latest revision of the *Service Table of Limits - SSP-1776*. If out of tolerance, replace the connecting rod and examine the crankshaft to make sure the crankshaft is not damaged.

12. Tappet Inspection

NOTICE: The roller tappets are not field repairable and no disassembly is allowed. If the engine has over 2000 operating hours, replace the roller tappets. Otherwise, during maintenance, complete a visual inspection of each roller tappet (Figure 39) for integrity and free rotation of the roller which are acceptable to return in-use roller tappets to service. Replace a damaged or corroded roller tappet or one that does not turn freely with a serviceable tappet. Refer to the latest revisions of Service Instruction Nos. SI-1011 and SI-1514.

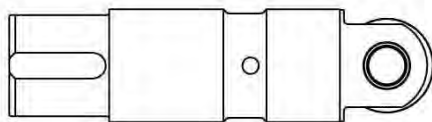


Figure 39
Hydraulic Roller Tappet

13. Crankshaft Assembly

A. Alignment Dowel Replacement

- (1) Use a center punch to mark the center of the exposed surface of the installed alignment dowel.
- (2) Mark a 1/8 in. drill bit to limit the depth of the drilled hole to 0.6 in. (15.14 mm).

⚠ CAUTION: USE CARE NOT TO DRILL DEEPER THAN THE MARKED DEPTH LIMIT OF THE DRILL. DO NOT LET THE DRILL MAKE CONTACT WITH THE REAR OF THE CRANKSHAFT.

- (3) Drill a 1/8 in. (3.18 mm) diameter hole through the center of the installed alignment dowel.
- (4) Fill the new drilled hole with oil.
- (5) Put a piece of 1/8 in. diameter drill rod in the drilled hole.
- (6) Use a hammer or mallet to hit the end of the drill rod.
- (7) Hydraulic pressure from the oil will push out the alignment dowel from the crankshaft.

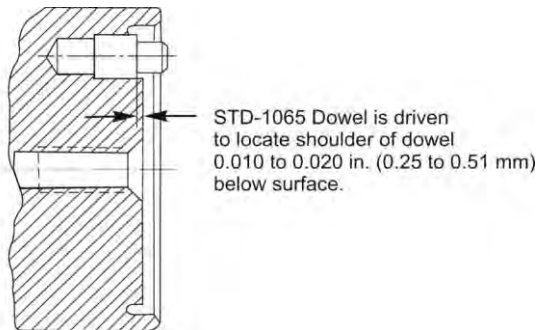


Figure 40
Section Through Counterbore End of Crankshaft Showing Driven Height of the Dowel

- (8) Remove and discard the alignment dowel.
- (9) Examine the bottom of the alignment dowel hole to make sure that the drill bit did not make contact with the bottom of the hole. If the drill bit made contact with the bottom of the hole, send the crankshaft to the factory for evaluation.
- (10) Press the replacement alignment dowel into the alignment dowel hole to the required driven height. Refer to Figure 40 or the latest revision of Service Bulletin No. SB-475 and its supplements for the alignment dowel part number and the correct driven height.

B. Crankshaft Gear Installation

- (1) Start with a clean crankshaft that passed the “Crankshaft Inspection” in this chapter.
- (2) Make sure the mating surfaces of the crankshaft gear and crankshaft counter-bored end are clean and dry and that there is no debris. Refer to the procedure “Crankshaft Cleaning” and Crankshaft Counterbore Cleaning” in Chapter 5-30 in this manual.
- (3) Install the crankshaft (with the counter-bored end vertically upright) securely in a holder.
- (4) Install the crankshaft gear on the alignment dowel of the crankshaft counter-bored end as shown in Figure 41. Use a soft mallet as needed to seat the gear in place.

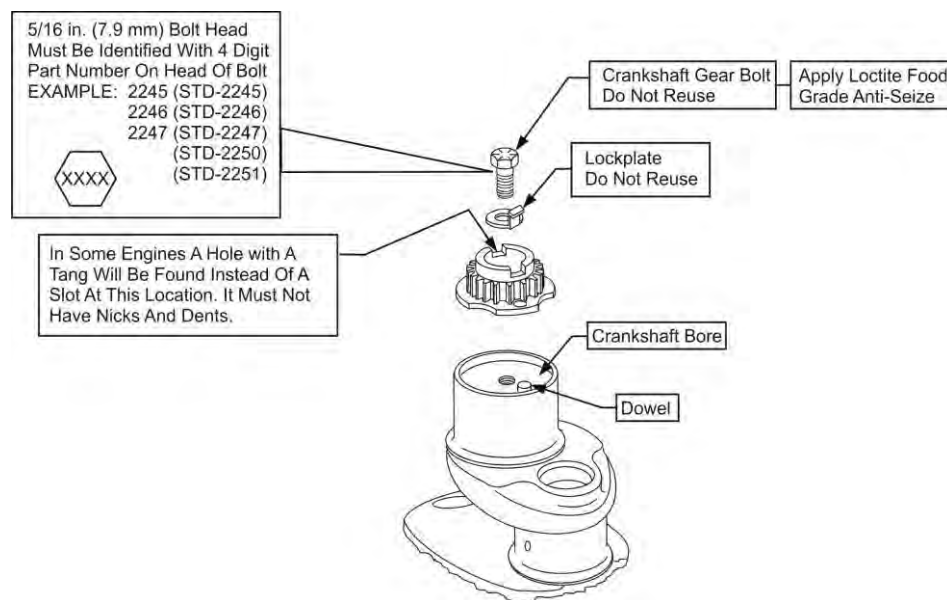


Figure 41
Crankshaft Gear Bolt and Lockplate

⚠ CAUTION: DURING CRANKSHAFT ASSEMBLY, ALWAYS INSTALL A NEW CRANKSHAFT GEAR BOLT AND NEW LOCKPLATE. DO NOT REUSE EITHER THE CRANKSHAFT GEAR BOLT OR LOCKPLATE.

- (5) Refer to the latest revision of Service Bulletin No. SB-475 or the applicable parts catalog to identify the correct part number for the new crankshaft gear bolt and lockplate for the applicable crankshaft gear part number.
- (6) Make sure that the threads on the new crankshaft gear bolt (Figure 41) and the threads in the counterbored end of the crankshaft are clean and dry and that there is no debris.

- (7) Apply a small amount of Loctite® Food-Grade AA anti-seize lubricant or equivalent to the bottom three or four threads of the new crankshaft gear bolt. Wipe away any excess lubrication.

NOTICE: Do not bend the tab on the lockplate yet.

- (8) Install a new lockplate and new crankshaft gear bolt with the part number on the top of the bolt head.
- (9) Initially torque the crankshaft gear bolt (regardless of size) to 125 in.-lb (14.12 Nm) torque. Do not bend the lockplate at this time.

CAUTION: FOR CORRECT ENGINE OPERATION, THE CRANKSHAFT GEAR MUST BE INSTALLED CORRECTLY WITH NO GAP BETWEEN THE MATING SURFACES OF THE COUNTERBORED-END OF THE CRANKSHAFT AND THE CRANKSHAFT GEAR PILOT FLANGE (FIGURE 42).

- (10) With a hammer and brass drift, tap lightly around the pilot flange of the crankshaft gear and listen for sharp solid sounds from the hammer blows that would indicate that the crankshaft gear is seated against the crankshaft.

(11) Make sure the crankshaft gear seats firmly and perpendicularly flat and straight (not at a slanted angle) against the crankshaft as shown in Figure 42:

- (a) Try to insert a pointed 0.001 in. (0.025 mm) feeler gage or shim between the pilot flange of the crankshaft gear and crankshaft counterbore at each of the three scallops on the pilot flange of the crankshaft gear. The feeler gage must NOT fit between the two surfaces at any location. There must not be any gap or clearance between the crankshaft counterbored end and the pilot flange of the crankshaft gear.

- (b) If clearance is found, remove the crankshaft gear bolt, lockplate, and crankshaft gear.

- (c) Make sure the mating surfaces of the crankshaft gear and crankshaft counterbore are clean and dry and that there is no debris.

- (d) Reinstall the crankshaft gear, lockplate, and crankshaft gear bolt.

- (e) Torque the crankshaft gear bolt to 125 in.-lb (14.12 Nm).

- (f) Try to put a pointed 0.001 in. (0.025 mm) feeler gage or shim stock between the pilot flange of the crankshaft gear and crankshaft counterbore at each of the three scallops on the pilot flange of the crankshaft gear.

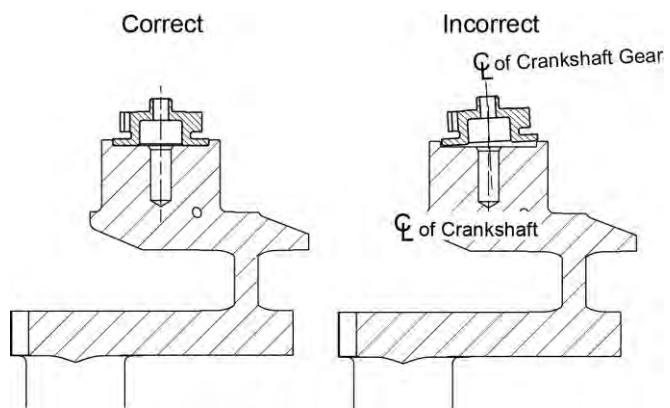


Figure 42
Seating of the Crankshaft Gear Against the Counterbored End of the Crankshaft

- (g) If there is still a gap, replace the crankshaft gear.
- (h) If there was no gap, the crankshaft gear is seated correctly.
- (i) Complete the final torque of the crankshaft gear bolt to 204 in.-lb (23.05 Nm).

⚠ CAUTION: IN THE NEXT STEP, DO NOT BEND TABS OF THE LOCKPLATE OVER THE CORNERS OF THE CRANKSHAFT GEAR BOLT HEAD UNTIL AFTER THE BOLT IS FINAL TORQUED. DO NOT DECREASE THE TORQUE ON THE CRANKSHAFT GEAR BOLT TO ALIGN THE LOCKPLATE TABS.

(12) If necessary, turn the crankshaft gear bolt up to one additional hex to align the flats of the bolt head with the tabs on the lockplate. Bend the tabs on the lockplate onto the flats of the crankshaft gear bolt to hold the bolt securely in place.

C. Expansion Plug Installation

NOTICE: If a constant speed propeller is used, there is no expansion plug. Otherwise, a new expansion plug is necessary for this procedure. Refer to the applicable Illustrated Parts Catalog for the part number.

(1) Remove gasket maker from the crankshaft with acetone-soaked wipe.

NOTICE: Make sure the surface is clean and that there is no debris or gasket material to ensure a good seal when the new bead of gasket maker is applied in the next step.

(2) Apply a bead of Loctite® #2 Non-Hardening Gasket Maker or equivalent to the perimeter of a new expansion plug.

NOTICE: A driver and a press table can be used to press the expansion plug in the crankshaft bore.

(3) Install the new expansion plug with the convex side out (Figure 43).

(4) Install the plug where it is seated firmly in the bottom of the crankshaft bore.

(5) Remove excess gasket material with a clean cloth soaked with acetone.

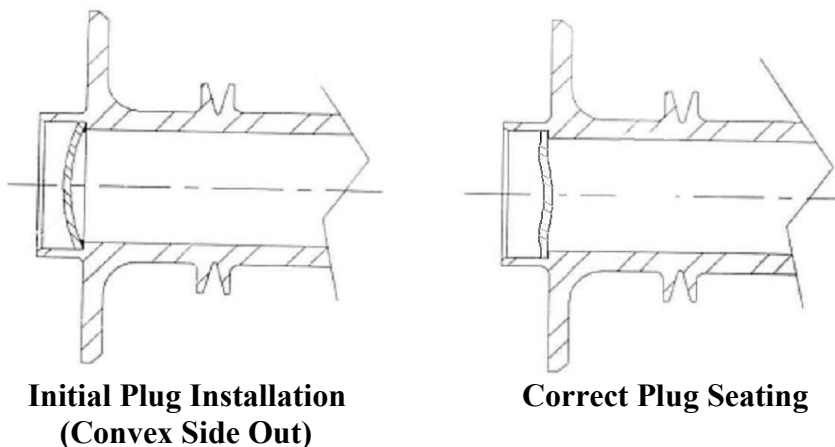


Figure 43
Installed Expansion Plug

D. Solid-Ring Crankshaft Oil Seal Installation

NOTICE: Install a *new* crankshaft oil seal during crankshaft assembly. There are two types of crankshaft oil seals: a split oil seal (Figure 44) and the solid-ring stretch oil seal (Figure 45). The split oil seal is open for easy assembly around the crankshaft. The solid-ring oil seal has more elasticity and can be stretched over the crankshaft propeller flange. The solid-ring oil seal can be installed on the crankshaft *before* or *after* the crankshaft is installed in the crankcase. The split oil seal is installed *after* the crankshaft is installed in the crankcase.



Figure 44
Split Oil Seal



Figure 45
Solid-Ring Oil Seal

NOTICE: An oversize crankshaft oil seal could be necessary if the crankcase bore size was increased. Part numbers for oversized parts include a “P” suffix, such as –P10 and are identified on the face of the seal. Except for the revised outside diameter of the seals, the oversize seals are identical in other aspects to the standard size seals. For correct sealing remove all traces of the oil sealant and oil from the crankcase before a new crankshaft oil seal is installed.

(1) Solid-Ring Oil Seal Installation

- (a) If not already done, complete the “Starter Ring Gear Support Removal” procedure in Chapter 72-70.
- (b) Examine the propeller flange, crankshaft sealing surface, and the crankcase seal bore recess for any scratches or nicks that damage or cause the seal to leak; if found, remove with fine emery cloth (150 to 220 grit for very light metal sanding) or equivalent small fine abrasive stone. Remove any residue.

⚠ CAUTION: ONLY APPLY MEK SOLVENT TO THE CRANKCASE, INCLUDING THE CRANKCASE BORE AND GROOVE FOR THE CRANKSHAFT OIL SEAL. DO NOT APPLY MEK SOLVENT TO THE CRANKSHAFT OIL SEAL SINCE MEK CAN CAUSE THE SEAL TO DETERIORATE. BE SURE THAT ALL TRACES OF CLEANING SOLVENT, OIL AND SEALANT ARE REMOVED PRIOR TO INSTALLATION OF A NEW CRANKSHAFT OIL SEAL.

- (c) Clean the crankcase bore, use a clean disposable lint-free cloth and any of the following cleaning solvents to remove oil, sealant, and debris from the crankcase, especially the crankcase bore which has the groove for the crankshaft oil seal:
 - Methyl-Ethyl-Ketone (MEK)
 - Acetone
 - Napasco SC-200
 - M-17
 - M-114.

NOTICE: There are two types of springs used for the seal spring. One type has a hook on each end; the hooks are joined together. The other type has threaded ends; one end will be screwed into the other end.

- (d) Remove the spring from the groove (open portion) of a new solid-ring oil seal (Figure 45).
- (e) Put a brass pin approximately 9/32 in. diameter by 3 in. long through the crankshaft propeller flange bushing to hold both sides of the seal in place as shown in Figure 46.
- (f) Apply a thin film of Lubriko M-6 grease or equivalent on the sealing surface of the seal, around the crankshaft at the sealing surface, and on the outer edge of the crankshaft flange.
- (g) Install the oil seal over the edge of the crankshaft propeller flange with the groove (open portion) of the seal towards the crankshaft propeller flange. Refer to Figure 46.
- (h) Install the Crankshaft Oil Seal Installation Tool ST-383 under the seal and over the edge of the crankshaft propeller flange as shown in Figure 46. Use even pressure with your hand, carefully turn the tool to force the oil seal over the crankshaft propeller flange and use care not to damage the seal.

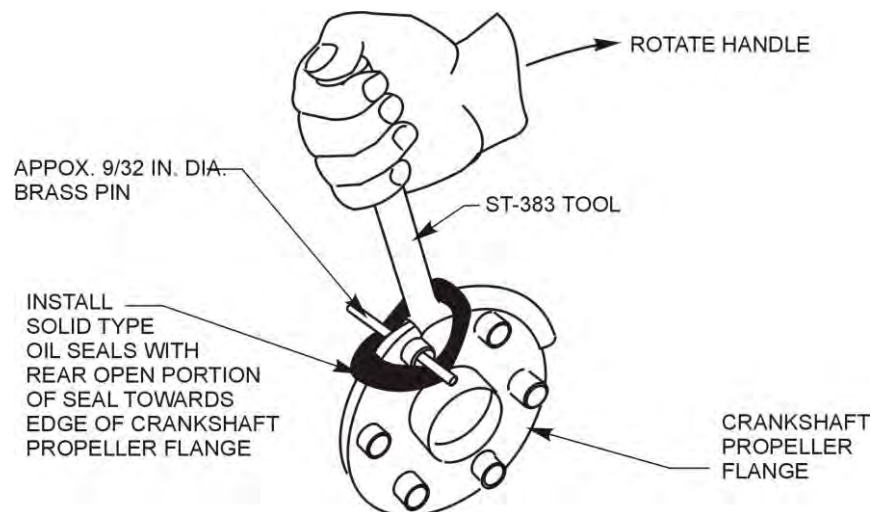


Figure 46

Crankshaft Propeller Flange Showing the Installation of the Solid-Ring Oil Seal

NOTICE: There are two types of springs used for the seal spring. One type has a hook on each end; the hooks are joined together. The other type has threaded ends; one end will be screwed into the other end.

- (i) Put the seal spring around the crankshaft, join the two ends together. The spring must be a continuous circle around the crankshaft with no kinks or twists.
- (j) Work the spring into position in the groove (open portion) in the rear side of the oil seal.
- (k) Use ethyl alcohol and disposable wipes to clean the outer surface of the seal and the crankcase seal bore recess.

This oil seal installation procedure is completed after the crankcase halves are joined together. Refer to the latest revision of Service Instruction No. 1324 for any new details.

E. Connecting Rod Installation

NOTICE: Each connecting rod is identified by a letter (A, E, S, etc.) as a designation for weight class. All of the connecting rods installed on the crankshaft must be of the same weight class.

- (1) Ensure that all of the connecting rods have the same weight class letter.
- (2) Apply specified lubricant to the connecting rod bearings (per the latest revision of Service Instruction No. SI-1059) in Figure 47. Different lubricants are used on the connecting rod bearings.

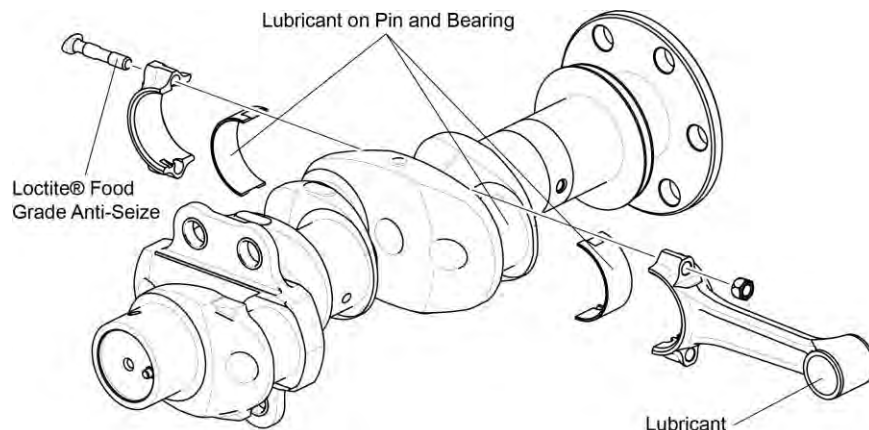


Figure 47
Connecting Rod Assembly Lubrication

NOTICE: Anytime either the connecting rod bolt and/or nut pairs are removed from a Lycoming engine, replace **both** the bolt and nut pairs with new “Service Use Only” hardware regardless of apparent condition.

- (3) Refer to the latest revision of Service Instruction No. SI-1458 to identify the correct P/Ns for the new connecting rods bolts.
- (4) Make sure the new connecting rod bolt and new nut pairs are clean, free of dirt and debris and that the threads are not damaged.
- (5) Install the new lubricated matched set bearing insert pair on each connecting rod, one bearing insert on the connecting rod and the other bearing insert on the connecting rod cap. Ensure that the tang of each bearing insert fits and seats within the slot of either the connecting rod as well as the connecting rod cap.

NOTICE: Do not install standardized connecting rod bolts in connecting rods with oversize bolt holes. Refer to the latest revision of Service Instruction No. SI-1458 for details.

- (6) Apply Loctite® Food-Grade Anti-Seize Lubricant or equivalent to the bottom two or three threads of the new connecting rod bolts (Figure 47). Wipe away excess lubricant with a clean, lint-free cloth.
- (7) Apply engine oil mixture to the crankpin journals.
- (8) Install each connecting rod pair (with the bearing inserts installed) on their respective crank pins on the crankshaft (where the numbers on the connecting rods and bearing locks point down - toward the oil sump.)

⚠ CAUTION: CORRECT INSTALLATION OF THE NEW NUT ON EACH NEW CONNECTING ROD BOLT IS NECESSARY FOR CORRECT CONNECTING ROD ASSEMBLY. EACH CONNECTING ROD NUT HAS TWO DIFFERENT SURFACES, ONCE SURFACE IS FLAT AND THE OTHER IS CHAMFERED AND HAS A RAISED LIP. BE SURE TO INSTALL EACH NUT ON THE CONNECTING ROD BOLT WITH THE FLAT FACE TOUCHING THE ROD. THE CHAMFERED RAISED LIP SURFACE IS AWAY FROM THE ROD.

- (9) Install a new nut on each new connecting rod bolt where the flat face of the nut touches the connecting rod as shown in Figure 48.
- (10) Torque the connecting rod bolts per the torque values in the latest revision of Service Instruction No. SI-1458. (Stretch bolts require an initial torque and are then torqued to the correct stretched length.)
- (11) Measure the side clearance between the connecting rod and crankshaft with a feeler gage where shown in Figure 49. The clearance is to be 0.004 to 0.016 in. (0.102 to 0.406 mm) (service or overhauled) and 0.004 to 0.010 in. (0.102 to 0.254 mm) (on rebuilt engines). Compare the results to the measurements previously recorded.

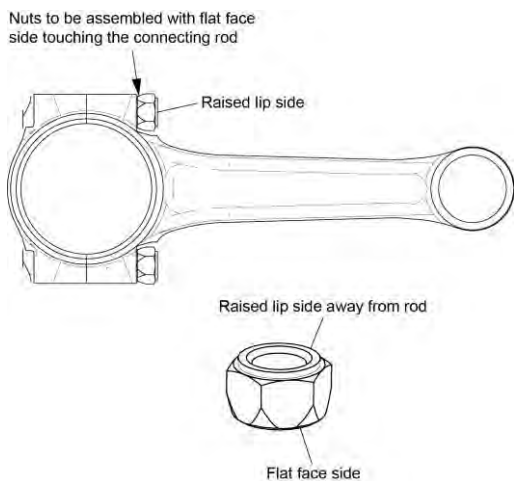


Figure 48
Connecting Rod Nut Installation

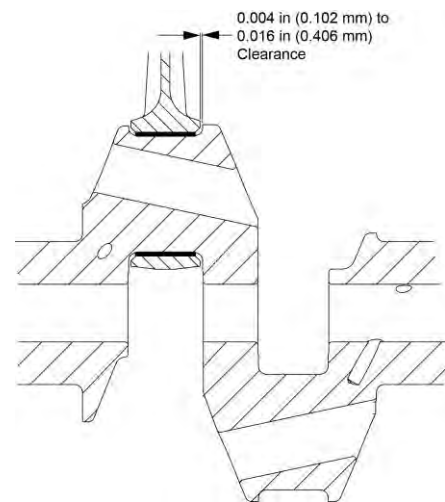


Figure 49
Connecting Rod Side Clearance

F. Counterweight Installation

⚠ CAUTION: DURING INSTALLATION, DO NOT MAKE SCORES, SCRATCHES, OR ETCH MARKINGS OF ANY KIND ON THE CRANKSHAFT, COUNTERWEIGHTS AND ROLLERS. A MARK IN ANY OF THESE AREAS CAN CAUSE THE PART TO WEAKEN AND TO FAIL.

- (1) Make sure the counterweights of the correct order and part number are to be installed on the crankshaft. Refer to the latest revision of Service Instruction No. SI-1012.

⚠ CAUTION: DO NOT INSTALL TWO DIFFERENT ROLLERS ON THE SAME COUNTERWEIGHT. ALL MUST BE MATCHED PAIRS OF IDENTICAL PARTS.

- (2) Measure the outside diameter of each roller to be installed to make sure it is in compliance with the dimensions in the latest revision of Service Instruction No. SI-1535.

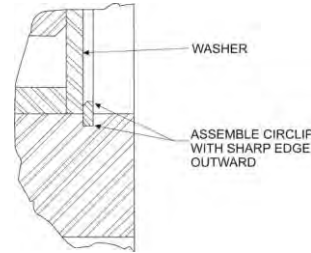
(3) Install the roller pair in the counterweight.

NOTICE: Refer to the applicable parts catalog for counterweight bushing part numbers

(4) Install new counterweight bushings per instructions in the latest revision of Service Instruction No. 1143.

NOTICE: A new circlip pair and a new pair of washers must be installed on each counterweight during assembly. Refer to the latest revision of Service Instruction No. SI-1535 to identify the correct P/N for the new circlips.

(5) Install a new counterweight washer in each of the two holes on the counterweight as shown in Figure 50.



(6) Install the new circlip on one side of each counterweight with the sharp edge outward as shown in Figure 50.

(7) Install the applicable counterweight on the correct crankshaft lobe and configuration as identified in the applicable parts catalog

Figure 50
Assembly of Circlips in Counterweight

(8) Use the specified Lycoming gage set identified in the latest revision of Service Instruction No. SI-1535. Make sure the circlips are installed correctly on the counterweight (Figure 50). Figure 51 shows the location of the A and B dimensions. Dimension A is the diameter of the gage. Dimension B is the width of the gage.

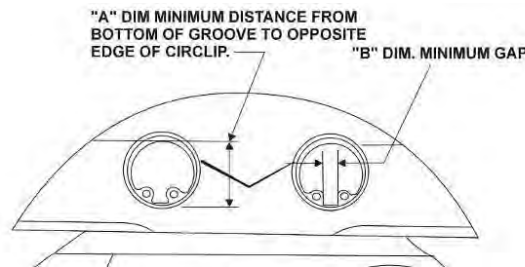


Figure 51
A and B Dimensions

(9) Make sure the circlip seating is correct (Figure 53) as follows:

(a) Install one end of the counterweight Circlip Check Gage, P/N 64892-2 or -3 (Figure 52). between the ends of the circlip (Figure 54).



Figure 52
Circlip Check Gage P/N 64892



Figure 53
Circlip Installed



Figure 54
Insertion of Circlip Check Gage

- (b) Make sure the gage is on the bottom of the groove.
 - (c) Pass the gage through the ends of the circlip.
 - (d) Move the gage back and forth.
 - (e) The gage must pass the ends of the circlip.
 - (f) When moved back and forth, the gage must be clear of the inside edge of the top of the circlip.
- (10) If the gage does not move freely between the ends and under the top of the circlip, the circlip seating is not correct. Install the circlip again and complete a check of the circlip seating again per the previous steps. The circlip must be seated correctly.

14. Piston Cooling Nozzle Installation (if removed)

- A. Apply a coating of engine oil to all of the cleaned and inspected/acceptable piston cooling nozzles.
- B. Install two piston cooling nozzles in each crankcase half (Figure 55).
- C. Torque each piston cooling nozzle to 100 in.-lb. (11 Nm).

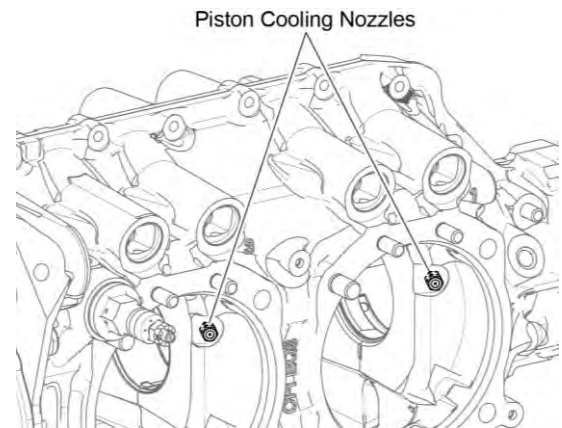


Figure 55
Piston Cooling Nozzles

15. Crankshaft Idler Gear Shaft Installation

- A. Install the crankshaft idler gear shaft (for the left idler gear) in the crankcase with a nut and bolt (Figure 56). Torque the bolt to 17 ft.-lb. (23 Nm). Torque the nut to 12 ft.-lb. (16 Nm). Safety wire the nut and bolt as shown in Figure 57.
- B. Install the crankshaft idler gear shaft (for the right idler gear) in the crankcase with two bolts (Figure 56). Torque the bolts to 17 ft.-lb. (23 Nm). Safety wire the bolts as shown in Figure 57.

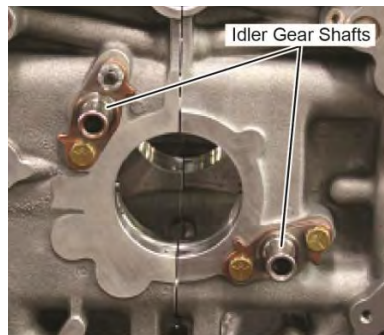


Figure 56
Shaft Installation in the Crankcase
for Left and Right Crankshaft Idler Gears

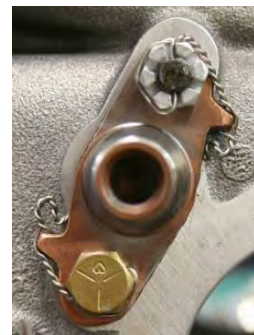


Figure 57
Safety Wire on the
Crankshaft Idler Gear Shaft

16. Oil Plug Installation (if removed)

- A. Make sure the 1/8 NPT oil plugs are acceptable, not damaged or cracked. Replace any worn, damaged or cracked NPT plug.
- B. Apply of coating of Loctite® 564 or equivalent to all six of the 1/8 NPT oil plugs.
- C. Install three of 1/8 NPT oil plugs in each crankcase half (Figure 58 A, B, and C).
- D. Torque each 1/8 NPT oil plug to 40 in.lb. (4.5 Nm).



Figure A



Figure B



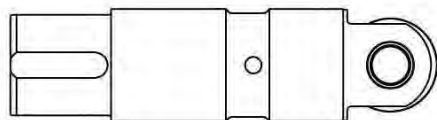
Figure C

**Figure 58 A, B and C
Oil Plug Installation Steps**

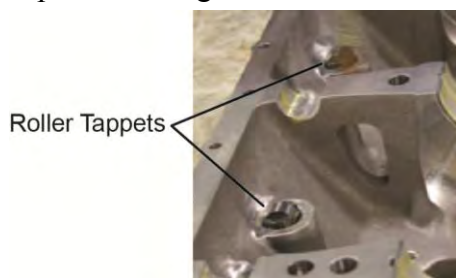
17. Tappet Assembly Installation

NOTICE: Roller tappets (Figures 59 and 60) are installed in the crankcase halves on Lycoming IO-390-C Series engine models.

Roller tappets are not field repairable and are not to be disassembled for parts re-use. Roller tappets only can be replaced and are to be replaced during overhaul.



**Figure 59
Roller Tappet**



**Figure 60
Installed Roller Tappets**

A. Plunger Assembly Installation

⚠ CAUTION: DO NOT MIX PLUNGER OR LIFTER ASSEMBLIES WITH DIFFERENT PART NUMBERS IN THE SAME ENGINE. THE DIFFERENT LEAK DOWN RATES WILL CAUSE INCORRECT ENGINE OPERATION. ALL PARTS OF EACH HYDRAULIC PLUNGER ASSEMBLY ARE SELECTIVELY FITTED AND ARE NOT INTERCHANGEABLE. MATING PARTS MUST BE KEPT TOGETHER. IF THERE IS ANY DOUBT AS TO WHETHER THE PARTS HAVE BECOME MIXED, INSTALL NEW PLUNGER ASSEMBLIES.

- (1) Clean and lightly coat the lifter parts with engine oil before assembly.
- (2) To assemble the unit, unseat the ball (Figure 61) by inserting a thin clean bronze wire through the oil inlet hole.
- (3) With the ball off its seat, insert the plunger and turn it clockwise until the spring engages.

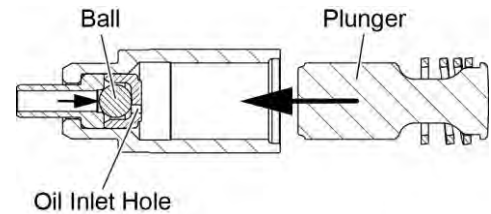


Figure 61
Hydraulic Lifter

B. Tappet Installation

NOTICE During maintenance, complete a visual inspection of roller tappets for integrity and free rotation of the roller action as acceptable to return an in-use roller tappet to service. However, during engine overhaul or in the event the engine is disassembled for a propeller strike or sudden engine stoppage, replace all eight roller tappets.

- (1) If the engine operation time is close to TBO, replace all of the roller tappets as a complete set with a new set of roller tappets. Otherwise, install the same serviceable roller tappets in the same location.
- (2) Before installation, apply lubrication to the roller tappets per the latest revision of Service Instruction Nos. SI-1011, SI-1059, and SI-1514.
- (3) Install four serviceable hydraulic roller tappets in each crankcase half during assembly.
- (4) Lubricate the camshaft lobes and the faces of the roller tappets (Figure 60) per the latest revision of Service Instruction No. SI-1059.

18. Crankshaft Bearing and O-Ring Installation

NOTICE: The crankshaft front bearings are installed on the crankshaft, not in the crankcase halves. Refer to the “Crankshaft Installation” procedure in this chapter.

NOTICE: If O-ring holes have a countersink, apply Lubriko M-6 grease to the countersink before installing the O-rings.

- A.** Install the center and rear crankshaft bearings. Make sure the tangs are seated in the lock slots (Figures 62 and 63).

- B.** Apply engine oil to eight new O-rings.
C. Install the new O-rings in the crankcase (Figure 63).

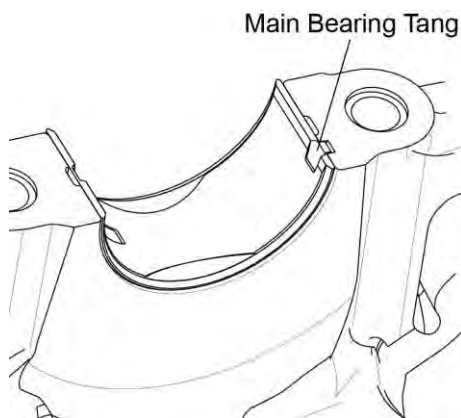


Figure 62
Main Bearing Tang

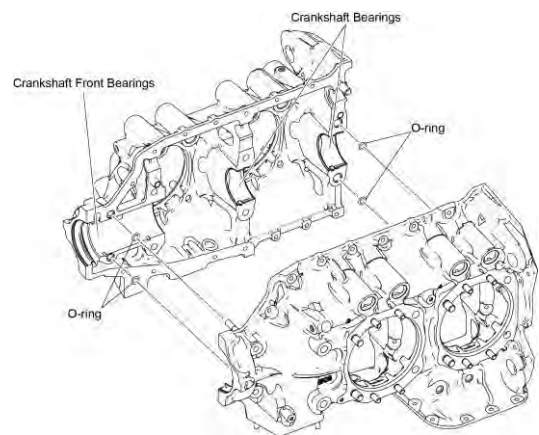


Figure 63
Main Bearings and O-Rings

19. Propeller Governor Drive Installation (Engines with Front-Mounted Propeller Governor Drives)

NOTICE: Examine each component to be installed on the propeller governor assembly. Replace any damaged or worn part with a new part. The gear assembly was to have been installed in the left crankcase half before crankcase assembly.

The following **new** parts must be available to install the propeller governor drive (Figure 12):

- Four lock washers
- Governor gasket
- Idler gear gasket
- Dowel pin (larger)
- Dowel pin (smaller)
- Set screw
- Thrust washer (different thickness sizes available - Table 2 - requires measurement of clearance in subsequent steps to identify the correct thrust washer)

Table 2
Thrust Washer Thickness

Thrust Washer Part Number	Thrust Washer Thickness	
	in.	mm
73249	0.0585 to 0.0595	1.4859 to 1.5113
73250	0.062 to 0.063	1.575 to 1.600
73251	0.0655 to 0.0665	1.6637 to 1.6891
73252	0.069 to 0.070	1.753 to 1.778
01L21418	0.055 to 0.056	1.397 to 1.422

A. Governor Drive Gear Installation

- (1) Lubricate the shaft of the governor drive gear with engine oil and install the governor drive gear in the left half of the crankcase.
- (2) Apply Lubriko M-6 grease or equivalent to the rear face of the propeller governor idler gear.
- (3) Install the propeller governor idler gear assembly, and thrust washer into the crankcase (Figure 64).
- (4) Install the propeller governor idler shaft into the crankcase through the propeller governor idler gear assembly and thrust washer (Figure 65).
- (5) Use the thickest thrust washer to keep the backlash at a low limit.



Figure 64
Propeller Governor Idler Gear Assembly and Thrust Washer

B. Backlash Check:

NOTICE: Refer to Section IV in the latest revision of the *Service Table of Limits - SSP-1776* for low limit and high limit propeller governor idler gear backlash.

- (1) To complete a check of the low limit backlash, insert a shim between the spacer and crankcase (Figure 66).



Figure 65
Propeller Governor Idler Shaft

- (2) Turn the propeller governor idler gear 90°. Record backlash. Remove and insert the shim at 90° intervals. Record the reading of each backlash check.
- (3) During assembly, to complete a check of the high limit backlash, try to insert a shim between the spacer and crankcase.

C. Propeller Governor Set Screw Installation

NOTICE: To ensure that there is adequate material in the set screw hole topeen on top of the set screw, use a new set screw that is shorter than the one previously removed. A smaller diameter center punch could be necessary. Refer to Figure 67.

- (1) Apply a light coat of Loctite® 290™ or equivalent to the new set screw. Wipe away any excess Loctite® 290™ or equivalent with a clean lint-free cloth.
- (2) Install the set screw into the crankcase (Figure 67). Align the idler gear shaft with the set screw to enable the set screw to lock into the indentation in the idler gear shaft to hold the idler gear shaft in place.
- (3) Torque the set screw 32 to 38 in.-lb. (3.6 to 4.3 Nm).
- (4) Use a smaller center punch (peening tool) with a 3/32-inch (2.38 mm) diameter at an approximate 50°/60° angle to peen the threads of the hole at the top of the taper above the set screw to prevent the set screw (as shown in Figure 68) from backing out.



Figure 66
Shim Between Spacer and Crankcase – Backlash Check



Figure 67
Set Screw Location

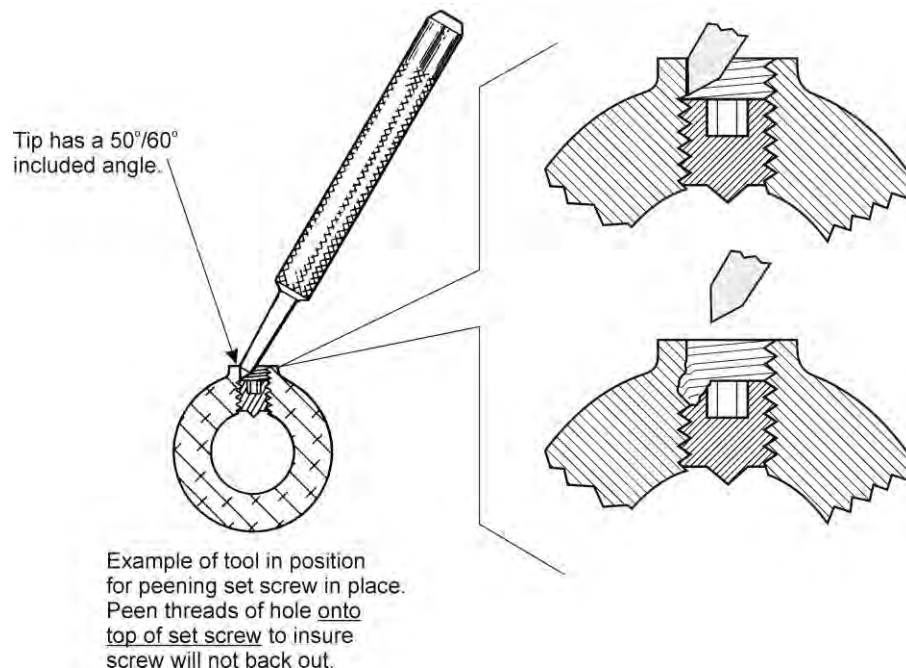


Figure 68
Center Punch (Peening Tool) for Set Screw

D. Propeller Governor Plug Installation

- (1) Examine the propeller governor plug (Figure 69) to make sure it is not damaged or cracked. Replace a damaged or cracked propeller governor plug.
- (2) Lubricate the threads of the propeller governor plug with Anti-Seize.
- (3) Install the plug into the crankcase with a new gasket.
- (4) Torque the propeller governor plug between 150 to 180 in.-lb. (17 to 20 Nm).
- (5) Safety wire/cable the propeller governor plug.



Figure 69
Propeller Governor Plug

- E. Apply heavy lubricant such as Modoc or equivalent to the teeth on the idler gear and the governor drive gear.

NOTICE: The governor drive cover or mask is to prevent FOD during engine assembly and will be removed when the propeller governor is installed.

- F. Install a new governor gasket and governor drive cover (Figure 13) or mask on the propeller governor mounting pad.

- G. Install four nuts, new lock washers, and washers on the studs in the crankcase to attach the governor drive cover or mask. Torque the nuts in accordance with the latest revision of the **Service Table of Limits - SSP-1776**.

20. Camshaft Assembly and Installation

A. Camshaft Assembly

- (1) Install the tachometer shaft (Figure 70) with a new tachometer shaft centering spacer on the camshaft assembly.
- (2) Install a new internal retaining ring on the tachometer shaft.
- (3) Install a new pin in the tachometer shaft.

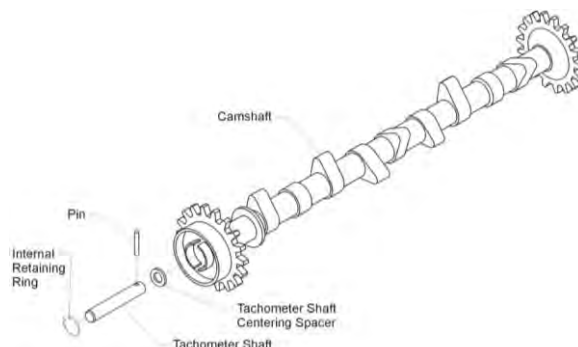


Figure 70
Camshaft Assembly

B. Camshaft Installation

NOTICE: Although there is only one camshaft, you will need to first install the camshaft in one crankcase half, complete an end play clearance check, remove the camshaft and install it in the other crankcase half to complete an end play clearance check. If a new or reconditioned camshaft is to be installed, install new tappet bodies. Refer to the “Camshaft Replacement Guidelines” section in the latest revision of Service Instruction No. SI-1011 for guidelines on replacing the camshaft when new tappets are installed in the engine.

- (1) Put the camshaft in the left crankcase half.

- (2) Complete a check of the end play clearance of the camshaft using a feeler gage (Figure 71).
- (3) Remove the camshaft from the left crankcase half and install it in the right crankcase half and complete a check of the camshaft end play clearance.

Acceptable end play clearance.	0.002 to 0.015 in. (0.051 to 0.381 mm)
--------------------------------	---

NOTICE: If the end play clearance values are not within the allowable limits, examine the crankcase and/or camshaft for wear or damage. Replace a damaged or worn camshaft. If one crankcase half is worn or damaged, replace both crankcase halves as a matched set.



Figure 71
Camshaft End Play Clearance Check

- (4) Apply engine oil mixture (15% pre-lubricant (STP or equivalent) and 85% SAE No. 50 mineral base aviation grade lubricating oil) to the camshaft slots and main bearings on each crankcase half (Figures 72 and 73) and the camshaft lobes (Figure 75).
- (5) Refer to the latest revision of Service Instruction SI-1059 and apply the specified lubricant to the crankshaft thrust bearing surfaces of each crankcase half (Figure 74).

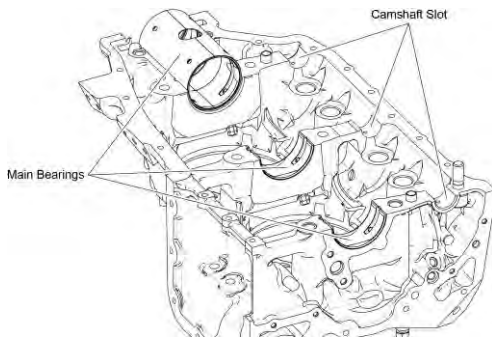


Figure 72
Main Bearings and Camshaft Slots in Crankcase Half

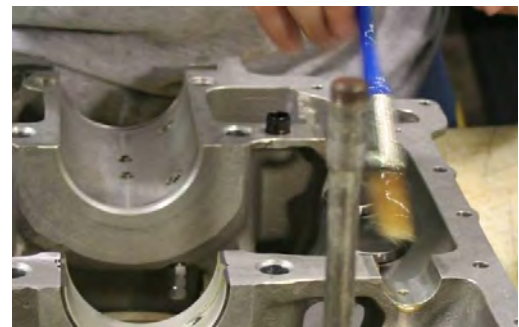


Figure 73
Lubricant Application to Camshaft Slot in Crankcase Half



Figure 74
Thrust Bearing Surfaces of Each Crankcase Half

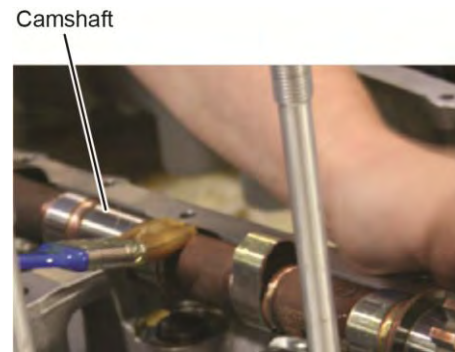


Figure 75
Lubrication on Camshaft Lobes

- (1) Tie a loop of soft wire around the camshaft and left crankcase half (as shown in Figure 76) to hold the camshaft securely in place.

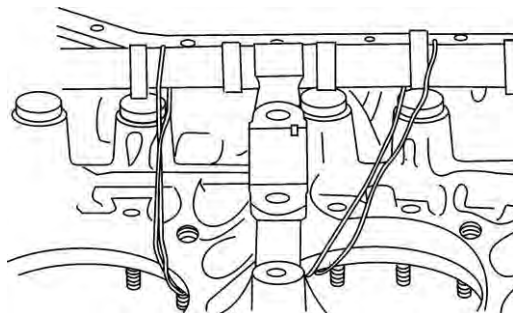


Figure 76
Example of Camshaft Wired to Crankcase Half

21. Crankshaft Installation

⚠ CAUTION: BEFORE INSTALLATION, MAKE SURE THE CRANKSHAFT HAS SATISFACTORILY PASSED THE MAGNETIC PARTICLE INSPECTION AND DOES NOT HAVE ANY CRACKS. DO NOT INSTALL A CRANKSHAFT WITH ANY CRACK(S). ENGINE MALFUNCTION CAN OCCUR IF A CRANKSHAFT WITH A CRACK IS INSTALLED.

NOTICE: The connecting rods are to have been already installed on the crankshaft per the “Connecting Rod Installation” procedure in this chapter.

- A. Apply engine oil mixture (15% pre-lubricant (STP or equivalent) and 85% SAE No. 50 mineral base aviation grade lubricating oil) to the main bearing journals of the crankshaft and the rear and center main bearing inserts in the right crankcase half.
- B. Install the Front Bearing Halves on the Crankshaft
 - (1) Apply a coating of engine oil mixture to the front main bearing halves.
 - (2) Install the front bearing halves, where they touch (butt together) around the crankshaft.
 - (3) Lift the crankshaft assembly by the connecting rods. Lower the crankshaft assembly into the crankcase half (Figure 77). Let the connecting rods extend through the cylinder base openings in the crankcase half.

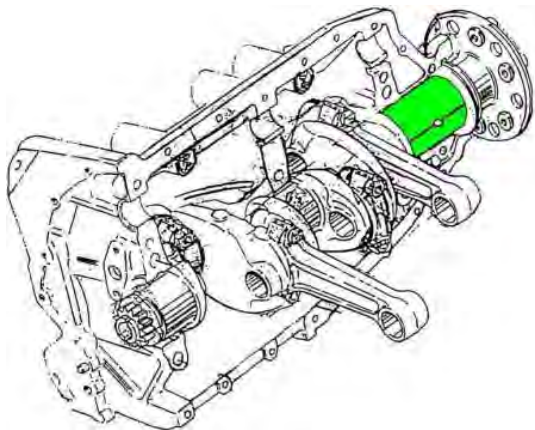


Figure 77
Crankshaft Installed in Crankcase Half

- (4) With the crankshaft assembly in the crankcase, align the dowel holes in the front bearing halves with the dowels in the crankcase.
 - (5) Make sure the front bearings are seated squarely over the locating dowels on the crankcase.
- C. Measure the Thrust Face Clearances Between the Crankshaft and Crankcase
- (1) With the crankshaft installed in the crankcase, move the crankshaft as far forward as possible.
 - (2) Use a feeler gage to measure the slinger clearance at Point A (Figure 78). Refer to the limits in Table 3. If the slinger clearance is not within the limits in Table 3, the front face of the slinger can be reground to restore the slinger clearance to within allowable limits.
 - (3) Move the crankshaft to the rear as far as possible.
 - (4) Use a feeler gage to measure the end play clearance with the crankcase thrust at Point B in Figure 78. Refer to the limits in Table 4. If the endplay clearance is not within the limits in Table 4, examine the crankcase and/or crankshaft for wear or damage. Replace a worn or damaged component.

Table 3

Slinger Clearance at Point A (Figure 78)

Inches	Millimeters
0.002 To 0.007	0.051 To 0.178

Table 4

Endplay Clearance at Point B (Figure 78)

Inches	Millimeters
0.009 To 0.026	0.229 To 0.660

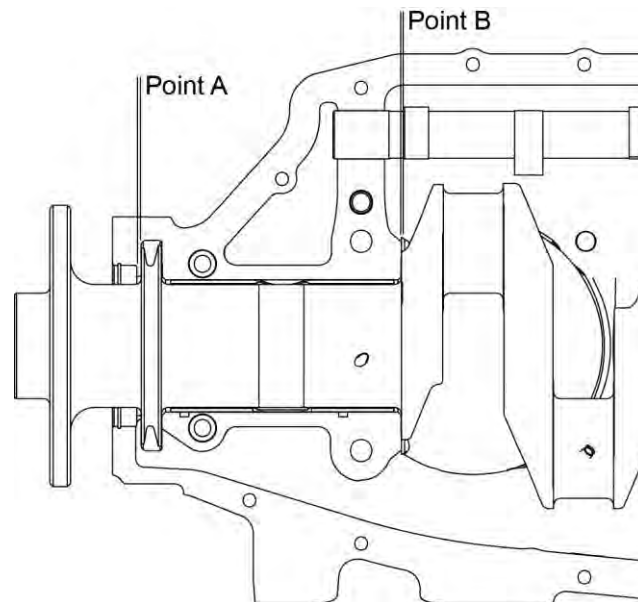


Figure 78

Clearance Between Crankshaft and Crankcase

22. Crankcase Assembly

NOTICE: Before assembly, make sure the crankcase has been cleaned per the “Crankcase Cleaning” procedure in Chapter 05-30 in this manual. If a crankcase stud is bent, broken, damaged, loose, rusted, corroded, or cannot be cleaned, refer to the “Crankcase Stud Replacement” procedure in Appendix A.

A. Assemble the Crankcase Halves

⚠ CAUTION: THE CRANKCASE HALVES ARE A MATCHED SET, IF ONE HALF IS CRACKED OR DAMAGED BOTH HALVES MUST BE REPLACED. ONLY LYCOMING-APPROVED SEALANTS ARE TO BE USED DURING CRANKCASE ASSEMBLY. USE OF ANY OTHER NON-APPROVED SEALANT COULD RESULT IN A LOSS OF CLAMPING FORCE AND/OR TORQUE.

IN THE NEXT STEP, DO NOT GET THE GASKET COMPOUND IN THE BORE OF THE NOSE SEAL OR IN ANY CRANKCASE BORE. IF ANY NON-HARDENING GASKET COMPOUND GETS INTO THE NOSE SEAL BORE OR ANY CRANKCASE BORE, CAREFULLY REMOVE THE GASKET COMPOUND WITH A SOFT CLOTH AND SOLVENT (ACETONE, MEK, OR EQUIVALENT). DO NOT GET MEK ON THE CRANKSHAFT OIL SEAL.

- (1) Apply a thin layer of non-hardening gasket material such as POB #4 Perfect Seal gasket compound or equivalent to the outside mating surfaces of each crankcase half (darker area shown in Figure 79.)
- (2) Measure and cut a total of four continuous lengths of "00" silk threads (four for only one crankcase half). Two of the lengths will extend along the entire length of the top of the crankcase flange as shown in Figure 79, and two silk thread lengths will be shorter to cover the distance shown on the bottom flange of the same crankcase half. Do not apply silk thread pairs to both crankcase halves.

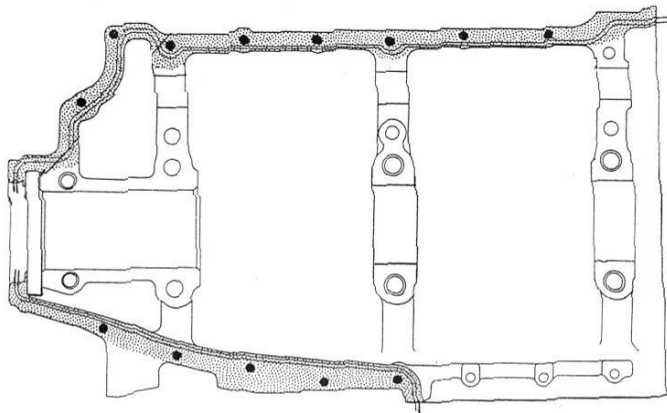


Figure 79
Area on the Crankcase Flange to Apply the POB Sealant and Silk Thread



Figure 80
Placement of Silk Threads Along Inside Edge of Crankcase Flange

⚠ CAUTION: TO ENSURE CORRECT SEALING, MAKE SURE THE SILK THREADS RUN THE LENGTH, AS A CONTINUOUS PIECE, OF THE INSIDE OF THE CRANKCASE FLANGE (FIGURE 79) AND THERE ARE NO BREAKS IN THE ANY OF THE THREADS. BREAKS IN THE SILK THREAD CAN CAUSE THE CRANKCASE TO LEAK. MAKE SURE THE THREADS DO NOT CROSS OVER OR LAY OVER EACH OTHER (FIGURE 79) OR COVER A HOLE IN THE CRANKCASE FLANGE.

- (3) Press two lengths of "00" silk threads in the gasket compound on the top and bottom flange sides (of the crankcase half) (Figure 79) firmly in the gasket compound where both silk threads are oriented in the area between the bolt holes and the inside flange edge of the crankcase half (approximately between 0.020 to 0.040 in. (0.508 to 1.106 mm) apart as shown in Figure 80. Make sure that the silk thread lengths do not touch or cross over one another or cover a bolt hole.
- (4) All continuous silk thread lengths must extend not more than ¼-in. (6.35 mm) beyond the front and rear end of the crankcase half. Figure 81 shows the thread overhang extension into the seal groove on the front end of the crankcase half. Figure 82 shows the silk thread overhang extending from the rear of the crankcase half.

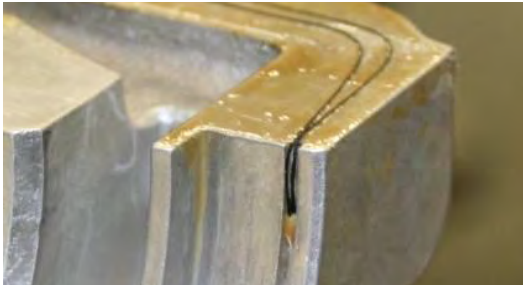


Figure 81

Silk Thread Extending into Seal Groove on the Front End of the Crankcase



Figure 82

Silk Thread Extending into the Rear End of the Crankcase

- (5) Wipe all excess sealant from the inner edges of the crankcase.

NOTICE: If a solid-ring stretch oil seal was installed on the crankshaft, make sure it is positioned toward the crankshaft flange and does not touch either crankcase half when the crankcase is assembled.

- (6) Lift the right half of the crankcase while keeping the halves parallel, lower the right half of the crankcase over and onto the left crankcase half for the studs to align.
- (7) When the crankcase halves are aligned correctly, tap the right half of the crankcase with a rubber mallet to make sure the crankcase halves are aligned and mated firmly all around and that there are no gaps between the mating flange surfaces. Do not continue if the crankcase halves are not aligned. Repeat the previous steps until the crankcase halves align.
- (8) Apply a coat of #2 Permatex® to the thru-studs at the dowel section.

CAUTION: BE SURE TO LUBRICATE THE CRANKCASE THRU-STUDS TO ENSURE CORRECT FASTENING OF THE CRANKCASE HALVES.

- (9) Lubricate each crankcase thru-stud with the specified lubricant identified in the latest revision of Service Instruction No. SI-1029.
- (10) Install thru-studs on the crankcase in the specified locations in Figure 83 where the studs extend equally on both sides of the crankcase. (An optional Crankcase Thru-Stud Driver ST-317 can be used to install thru-studs.)

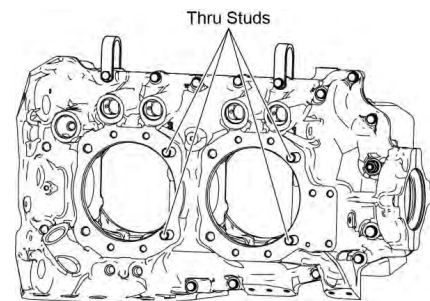


Figure 83

Right Side of Crankcase Showing Thru-Studs Installed

- (11) Install the Torque Hold-Down Plate (ST-222, Figure 84) on the cylinder pads over the thru-studs.
- (12) Attach the plates with washers and nuts on the thru-studs. Tighten the nuts only finger tight at this time.
- (13) Make sure that the plates remain parallel with the cylinder decks of the crankcase.

NOTICE: Before tightening the thru-studs, make sure that they extend equally for both sides of the crankcase.

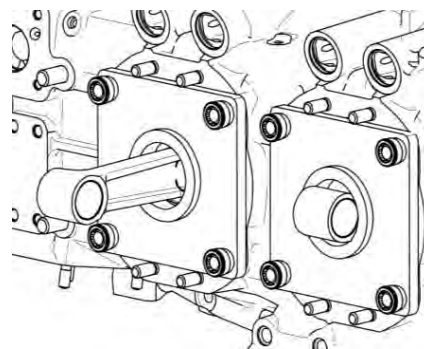


Figure 84
Torque Hold-Down Plates (ST-222)

CAUTION: TO ENSURE CORRECT ASSEMBLY OF THE CRANKCASE HALVES, TO MINIMIZE THE POSSIBILITY OF THE SUBSEQUENT LOOSENING OF CYLINDER BASE NUTS, AND TO ENSURE A UNIFORM LOAD ON THE MAIN BEARINGS IN THE CRANKCASE, FOLLOW THE STEPS IN THE TORQUE SEQUENCE IN THE ORDER GIVEN IN FIGURE 85.

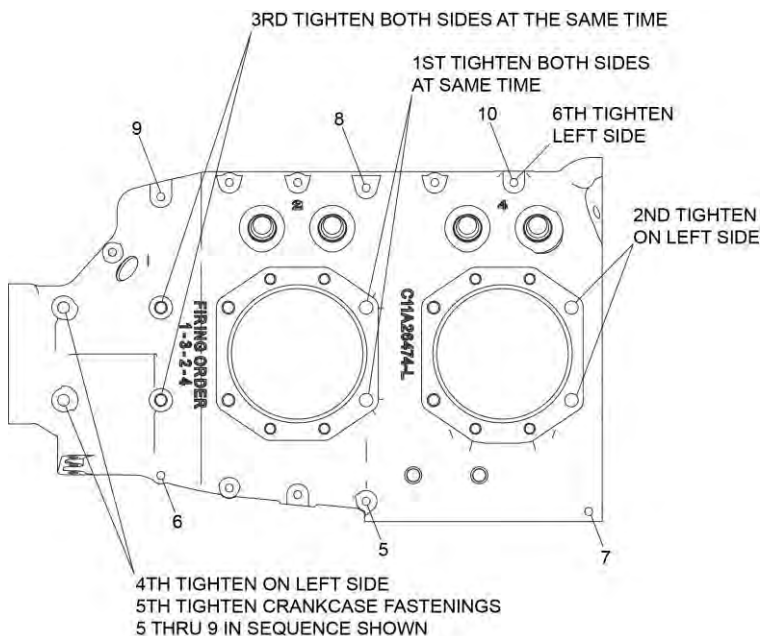


Figure 85
Crankcase Tightening Sequence

- (14) Install a nut (and spacer as required) on each thru-stud at the mating flanges on the crankcase halves in the sequence shown in Figure 85 to attach the crankcase halves securely.

NOTICE: To ensure uniform loading on the main bearings, immediately torque the nuts on the anchored thru-studs and the free thru-studs in sequence (Figure 85), beginning at the center of the crankcase and then progressing alternately to the rear and front of the engine.

- (15) Tighten the nuts on thru-studs (to maintain bearing pre-load) at the:
 - (a) Rear of Cylinder 2 (tighten both sides at the same time).
 - (b) Rear of Cylinder 4 (tighten on the left side).
 - (c) Front of Cylinder 1 (tighten both sides at the same time).
- (16) Torque the nuts in sequence at positions 1st, 2nd, and 3rd to 25 ft.-lb (34 Nm).
- (17) Re-torque the nuts in sequence at positions 1st, 2nd, and 3rd to 50 ft.-lb. (68 Nm).
- (18) Torque the front bolts at position 4 on the left side to 25 ft.-lb (34 Nm).
- (19) Torque the 1/4-in. nuts at positions 5 thru 10 (in the order shown in Figure 85) to 96 in.-lb. (11 Nm).
- (20) Torque the remaining crankcase fasteners as indicated in Table 5.
- (21) Make sure all fasteners on the crankcase are torqued correctly and none are loose.
- (22) Install the 3/8 in. slotted nut and washer on the stud at the rear camshaft bearing (Figure 86). Torque the nut to 215 in.-lb. (24 Nm). Safety wire the nut as shown in Figure 86.
- (23) Apply Loctite® 564 or equivalent to the threads of the bolts (Figure 87) to be installed behind the governor pad.
- (24) Install the bolts behind the governor pad. Torque the bolts per the torque values listed in Table 5.



Figure 86

Nut on Stud at Rear Camshaft Bearing



Figure 87

Bolts Behind Governor Pad

⚠ CAUTION: MAKE SURE ALL FASTENERS ON THE CRANKCASE ARE TORQUED CORRECTLY AND NONE ARE LOOSE.

Table 5
Crankcase Fastener Torque Values

Fastener	Torque	Fastener	Torque
1/2-in. Nuts, thru-studs	50 ft.-lb. (68 Nm)	5/16 in. Bolts	17 ft.-lb. (23 Nm)
7/16-in. Nuts	35 ft.-lb. (48 Nm)	1/4 in. Nuts	96 in.-lb. (11 Nm)
3/8-in. Nuts	25 ft.-lb. (34 Nm)	1/4 in. Shear Nuts	55 in.-lb. (6 Nm)

NOTICE: Any additional crankcase fastenings not specifically called out in this procedure can be tightened in any sequence using the torque values shown above.

(25) Before the oil sump is installed, safety wire the nuts that will be inside the oil sump shown in Figure 88.



Figure 88
Safety Wire Nuts in Crankcase Oil Sump

23. Crankshaft Oil Seal Installation

NOTICE: If a solid-ring oil seal (Figure 45) is not already installed on the crankshaft a solid-ring oil seal or split oil seal (Figure 44) can be installed after the crankcase is assembled.

A. Install the solid-ring oil seal in the crankcase as follows:

- (1) Install a solid-ring oil seal on the crankshaft per “Solid-Ring Oil Seal Installation“.
- (2) Use solvent and wipe excess grease from the crankshaft flange.

⚠ CAUTION: DO NOT APPLY MEK SOLVENT TO THE CRANKSHAFT OIL SEAL SINCE MEK CAN CAUSE THE SEAL TO DETERIORATE. BE SURE THAT ALL TRACES OF CLEANING SOLVENT, OIL AND SEALANT ARE REMOVED PRIOR TO INSTALLATION OF A NEW CRANKSHAFT OIL SEAL.

- (3) Use ethyl alcohol and disposable wipes to clean the outer surface of the seal and the crankcase seal bore recess. Make sure nothing comes in contact with the cleaned surfaces.

⚠ CAUTION: USE A BRUSH AND BUTYL RUBBER GLOVES WHEN APPLYING SEALANT AND INSTALLING THE OIL SEAL (FIGURES 89 AND 90).

NOTICE: In the next step, do not get sealant on the crankshaft. If any sealant gets on the crankshaft, use acetone to remove all traces of sealant.

If Pliobond® #20 or Pliobond® #25 is substituted for Dow Corning® 737 Neutral Cure Sealant, refer to the manufacturer’s instructions for application details and cure time.

- (4) Apply a liberal coating of Dow Corning® 737 Neutral Cure Sealant to the outside diameter of the oil seal (Figure 89) to allow the excess sealant to squeeze out between the crankcase and the oil seal when the oil seal is installed.
- (5) Press the solid-ring oil seal firmly against the seat in the crankcase bore. Apply pressure all around the seal until it is firmly seated in the bore.

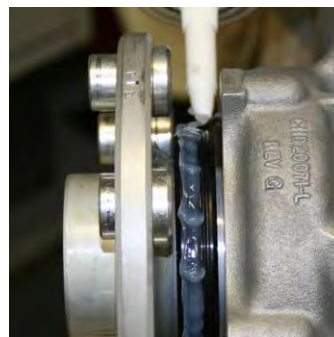


Figure 89
Apply the Sealant to the Oil Seal

- (6) Spread the excess sealant smoothly over the oil seal and crankcase (Figure 90)
- (7) Let the Dow Corning® 737 Neutral Cure Sealant to cure for 24 hours.



Figure 90
Spread the Excess Sealant

B. Install a split oil seal (Figure 44) in the crankcase as follows:

- (1) Apply a thin film of Lubriko M-6 grease or equivalent on the sealing surface of the seal and around the crankshaft at the sealing surface.

NOTICE: If Pliobond® #20 or Pliobond® #25 is substituted for Dow Corning® 737 Neutral Cure Sealant, refer to the manufacturer's instructions for application details and cure time.

- (2) Apply a coat of Dow Corning® 737 Neutral Cure Sealant to the split of the seal.
- (3) Face the propeller end of the crankshaft and assemble the split oil seal with the split at the 1:00 o'clock position (11:00 o'clock position for left-hand rotation engines) with the front face of the seal toward the crankshaft propeller flange.

⚠ CAUTION: DO NOT APPLY MEK SOLVENT TO THE CRANKSHAFT OIL SEAL SINCE MEK CAN CAUSE THE SEAL TO DETERIORATE. BE SURE THAT ALL TRACES OF CLEANING SOLVENT, OIL AND SEALANT ARE REMOVED PRIOR TO INSTALLATION OF A NEW CRANKSHAFT OIL SEAL.

- (4) Use ethyl alcohol and disposable wipes to clean the outer surface of the split oil seal and the crankcase seal bore recess. Make sure nothing comes in contact with the cleaned surfaces.

⚠ CAUTION: USE A BRUSH AND BUTYL RUBBER GLOVES WHEN APPLYING SEALANT AND INSTALLING THE OIL SEAL (FIGURES 89 AND 90).

NOTICE: In the next step, do not get sealant on the crankshaft. If any sealant gets on the crankshaft, use acetone to remove all traces of sealant.

- (5) Apply a liberal coating of Dow Corning® 737 Neutral Cure Sealant to the outside diameter of the split oil seal (Figure 89) to allow the excess sealant to squeeze out between the crankcase and the oil seal when the oil seal is installed.
- (6) Press the split oil seal firmly against the seat in the crankcase bore. Apply pressure all around the seal until it is firmly seated in the bore.
- (7) Spread the excess sealant smoothly over the oil seal and crankcase (Figure 90)
- (8) Let the Dow Corning® 737 Neutral Cure Sealant to cure for 24 hours.

24. Crankshaft Idler Gear Installation

NOTICE: The left crankshaft idler gear has etched circles in two locations. The location with etched circles on two teeth side-by-side aligns with the single etched circle on the crankshaft gear (Figure 91). The other location with the etched circle is on a single gear tooth (Figure 92) and aligns between the two teeth with the etched circles on the camshaft gear. The correct orientation of these etched circles is necessary to ensure correct valve timing.

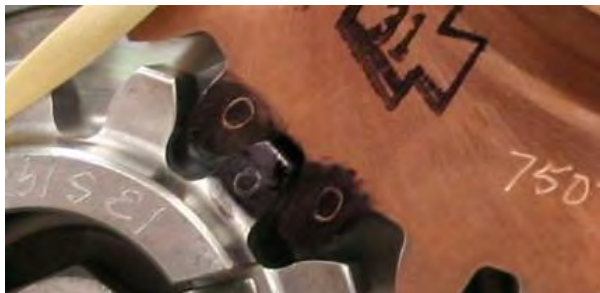


Figure 91

Correct Alignment Between the Crankshaft Gear and the Left Crankshaft Idler Gear



Figure 92

Correct Alignment Between the Camshaft Gear and the Left Crankshaft Idler Gear

- A. Install the left crankshaft idler gear (Figure 93) in place on the idler shaft with a new bushing (Figure 2). Turn the crankshaft gear and/or the camshaft gear to align the gears.
- B. Install the right crankshaft idler gear with a new bushing on the idler shaft located to the left of the crankshaft gear.
- C. Install a rubber band around the gears to hold them in place (Figure 94).

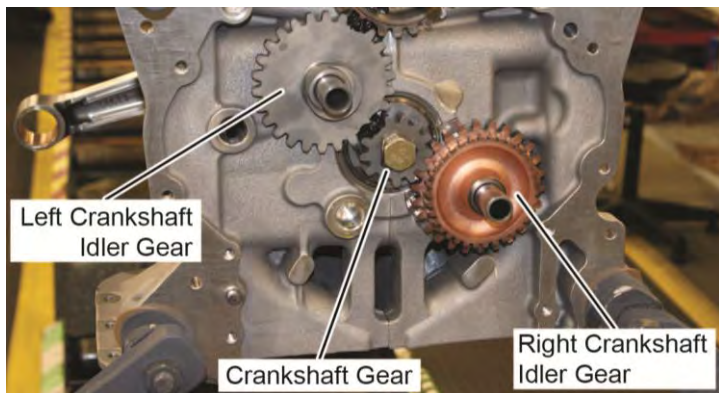


Figure 93

Crankshaft Idler Gears Installed



Figure 94

Rubber Band to Hold Crankshaft Idler Gears

25. Crankshaft Endplay Clearance Check

Complete the crankshaft endplay clearance check after the crankshaft is installed and the crankcase halves have been assembled. Verify the crankshaft endplay clearance is within acceptable limits.

- A. Attach a dial indicator gage to the crankcase starter pad.
- B. Move the crankshaft to the rear of the engine as far as possible.

- C. Position the dial indicator gage on the face of the crankshaft flange (Figure 95) and set the gage to read “0.”
- D. Slide the crankshaft to the front of the engine as far as possible.
- E. Read the dial indicator gage. The reading must be 0.009 and 0.021 in. (0.229 To 0.660 mm). If the endplay clearance is not within the limits, disassemble the crankcase and examine the crankcase and/or crankshaft for wear or damage. Replace a worn or damaged component.



Figure 95
Crankshaft Endplay Check

26. Propeller Oil Control Leak Test

- A. The purpose of this leak test is to identify any leaks, blockages (tight clearance) or openings (excessive clearance) of the propeller governor oil passages.
- B. Complete this leak test (with the propeller installed on the engine) if any of the following conditions occur:
 - Suspect damaged propeller governor
 - Sluggish propeller operation
 - Engine does not hold rpm during cruise, climb, or descent
 - Engine front main bearing has too much clearance
 - Engine goes into feather during landing rollout with a decreased power control setting

(1) Remove the propeller governor from the engine per the “Propeller Governor Removal” procedure in this chapter for engines with a front-mounted propeller governor or in Chapter 72-25 for engines with a rear-mounted propeller governor.

NOTICE: In the following steps, to prevent an air leak, use a propeller governor gasket P/N 72053 with test plate P/N ST-483 (Figure 96). Refer to the latest revision of Service Instruction No. 1462 for any updates.

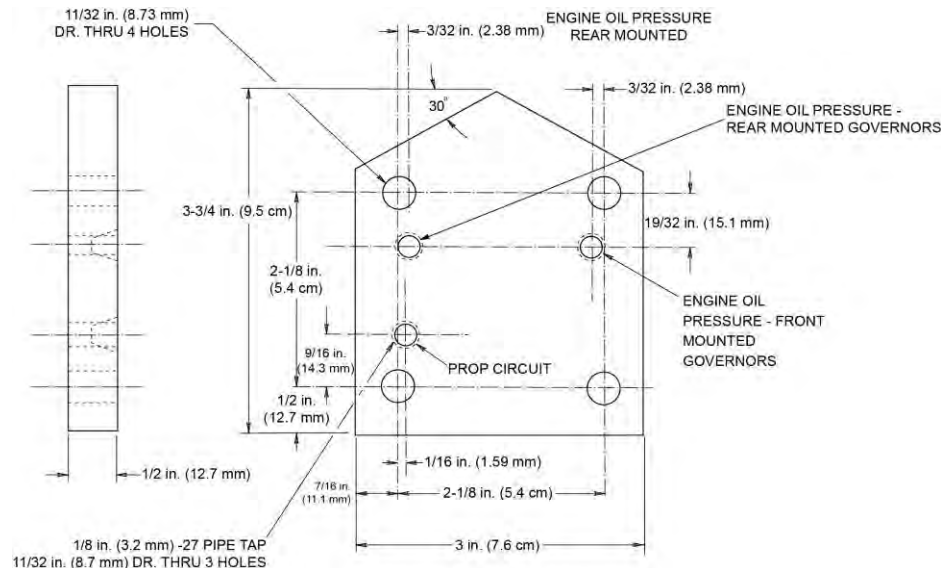


Figure 96
ST-483 Test Plate

- (2) Front-mounted propeller governors: Install the gasket and the test plate P/N ST-483, or equivalent on the governor pad with the air fitting in alignment with the governor oil passage that goes to the front bearing (forward hole) or left side of the mounting facing the pad. Refer to Figure 96.
- (3) Rear-mounted propeller governors: Install the left side bottom hole on the test plate P/N ST-483 on the front bearing and crankshaft transfer tube.
- (4) Connect a calibrated oil pressure gauge (0 to 100 psi) (0 to 689 kPa) to the appropriate engine oil pressure port on the test plate for your governor location. Install a plug in the propeller circuit and unused engine oil pressure circuit port.
- (5) Start and warm-up the engine until the oil temperature is within the correct operating range (Appendix A of the *IO-390-C Series Engine Installation and Operation Manual*.)

NOTICE: The oil pressure must not be more than 5 psi (34 kPa) below the lowest operating pressure of the operating range when the engine rpm is in the usual operating range.

- (6) With the engine OFF, remove the plug from the propeller circuit port and install a compression tester (Chapter 72-30) at the propeller circuit fitting on the test plate.

NOTICE: Allow 5 minutes after adjusting the first gauge to 40 psi (276 kPa), for air pressure to stabilize, before reading the pressure on the second gauge.

- (7) Apply shop air to the differential pressure regulator and adjust it to 40 psi (276 kPa) on the Gauge No. 1 (Figure 97. With the engine at operating temperature, the pressure reading on the Gauge No. 2 must read 6 to 35 psi (41 to 241 kPa), if the system is operating correctly.

NO. 1 GAUGE 40 psi (276 kPa)

NO. 2 GAUGE 6 psi to 35 psi (41 to 241 kPa) ACCEPTABLE

Above 35 psi (241 kPa)

Insufficient front main bearing clearance or a blockage in the propeller governor circuit

Below 6 psi (41 kPa)

Excessive front main bearing clearance

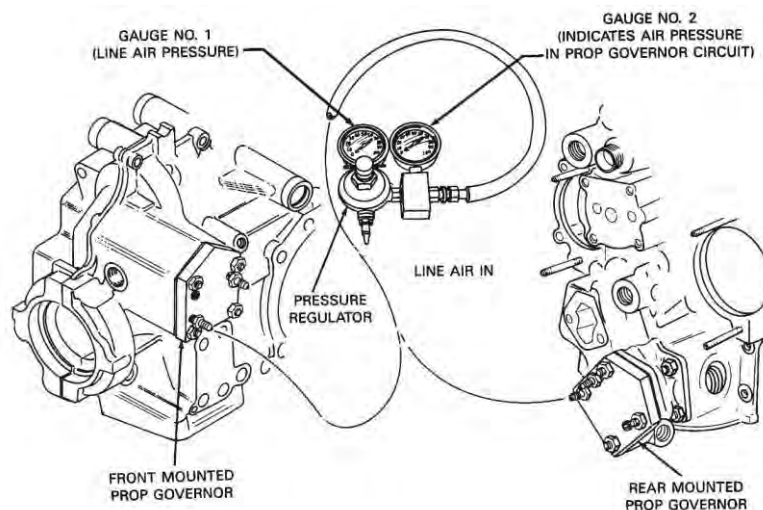


Figure 97
Propeller Governor Circuit Testing

- (8) Remove the test plate P/N ST-483 and gasket. Discard the gasket.
 - (9) Install the propeller governor on the engine per the “Propeller Governor Installation” procedure in this chapter for engines with a front-mounted propeller governor or in Chapter 72-25 for engines with a rear-mounted propeller governor.
27. Propeller Governor Removal (Engines with Front-Mounted Propeller Governor Drives)
- A. Remove the nuts lock washers and washers from the studs in the propeller governor mounting pad. Discard the lock washers.
 - B. Remove the propeller governor and governor gasket. Discard the gasket.
28. Propeller Governor Installation (Engines with Front-Mounted Propeller Governor Drives)
- A. If a cover or mask is installed on the propeller governor mounting pad, remove the nuts and cover or mask.
 - B. Install the propeller governor in accordance with the aircraft manufacturer’s instructions.
29. Crankshaft-to-Camshaft Timing Check

NOTICE: This timing check is completed on a partially or fully assembled engine without removing the accessory housing.

- A. Make sure the ignition and all electrical switches are OFF.
- B. Disconnect all spark plug leads.
- C. Disconnect the starter.
- D. Remove the top spark plug on Cylinder 1 as per the “Spark Plug Removal” procedure in Chapter 74-20.
- E. Remove the rocker box cover on Cylinder 2 as per the “Exhaust Valve and Guide Inspection” procedure in Chapter 72-30.
- F. Rotate the crankshaft to position Cylinder 1 piston at Top Dead Center (TDC) on the compression stroke.
- G. Monitor the movement of the intake and exhaust valves in Cylinder 2 as you turn the crankshaft to move the piston just past TDC of Cylinder 1.
- H. The crankshaft-to-camshaft timing is correct if the intake valve and the exhaust valve in Cylinder 2 just begins to close as the intake valve starts to open as the piston in Cylinder 1 goes over TDC on compression.
- I. If this simultaneous opening and closing of the intake and exhaust valves just past TDC does not occur, the crankshaft-to-camshaft timing is not correct. Repeat this timing check. If the results are the same, remove the accessory housing and complete a check of the alignment of the crankshaft idlers gears per the “Crankshaft Idler Gear Installation” section in this chapter.
- J. If the crankshaft-to-camshaft timing is correct:
 - (1) Install the rocker box cover on Cylinder 2 with a new rocker box cover gasket as per the “Cylinder Installation” procedure in Chapter 72-30.
 - (2) Install the top spark plug on Cylinder 1 as per the “Spark Plug Installation” procedure in Chapter 74-20.
 - (3) Reconnect the starter.
 - (4) Reconnect all spark plug leads

This page intentionally left blank.

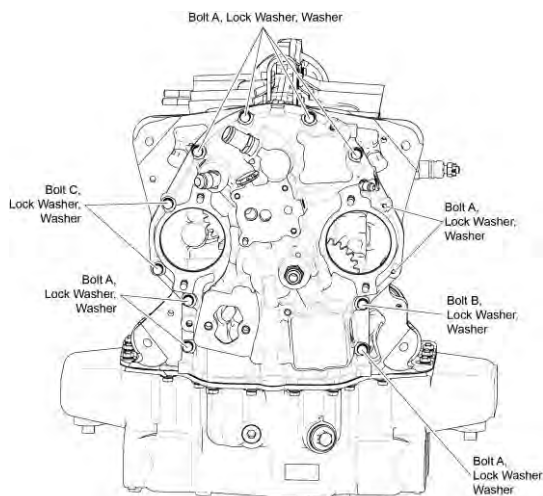
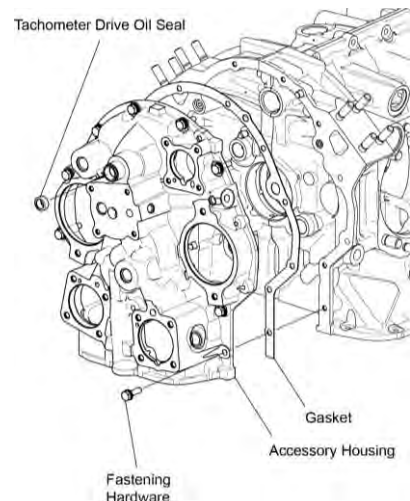
72-25 - ACCESSORY HOUSING MAINTENANCE

1. Accessory Housing Removal

- A. Remove any aircraft manufacturer installed accessories per instructions in the Aircraft Manufacturer's Maintenance Manual.
- B. If not already done, drain the oil from the oil sump per the "Oil Change Procedure" in Chapter 12-10.
- C. Remove the fuel pump per instructions in Chapter 73-10 of this manual.
- D. Remove the oil filter (if installed) per instructions in Chapter 12-10.
- E. Disconnect the hoses to the airframe-supplied oil cooler.
- F. Remove the vacuum pump per the "Vacuum Pump Removal" procedure in Chapter 72-60.
- G. Remove the vacuum pump driven gear per the "Vacuum Pump Driven Gear Removal" procedure in Chapter 72-60.
- H. On engines with a rear-mounted propeller governor drive, remove the propeller gear drive adapter assembly per the "Propeller Governor Drive Removal" procedure in Chapter 72-60.
- I. Remove any other accessories on the accessory housing per airframe manufacturer's instructions.

NOTICE: There are three different bolts used on the accessory housing. Identify and keep the bolts separate for correct reassembly.

- J. Remove all of the Bolts A, B, and C, lock washers, and washers from the external side of the accessory housing shown in Figure 1. Discard the lock washers.

**Figure 1****Hardware on External Side of Accessory Housing****Figure 2****Accessory Housing**

- K. While one person supports the accessory housing, remove the two bolts, lock washers, and washers from the other side of the accessory housing as shown in Figure 1. Discard the lock washers.
- L. Remove and discard the tachometer drive oil seal (Figure 2) from the accessory housing.
- M. Remove the accessory housing from the engine.
- N. Remove and discard the accessory housing gasket (Figure 2).

2. Oil Pump Removal

- A. Remove the safety wire (Figure 3) from the slotted nuts that attach the oil pump body to the accessory housing.



Figure 3
Oil Pump

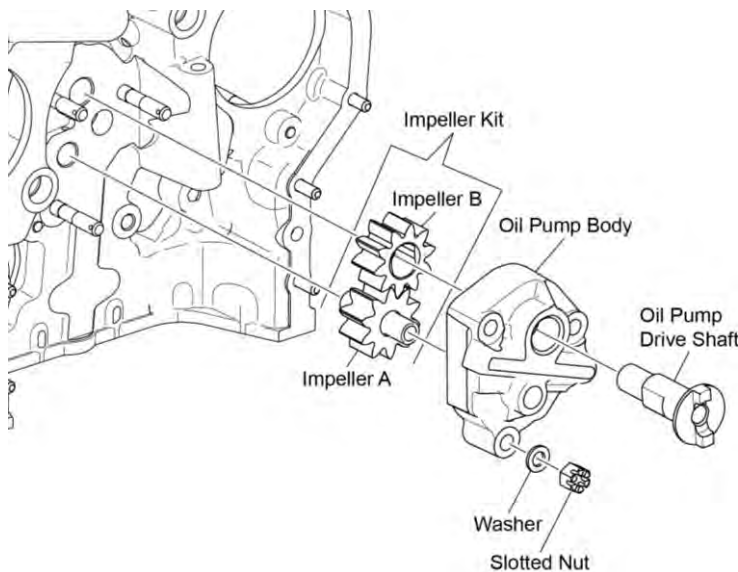


Figure 4
Oil Pump and Internal Side of the Accessory Housing

- B. Remove the three slotted nuts and three washers that attach the oil pump body to the accessory housing.
- C. Remove the oil pump body.
- D. Remove the oil pump drive shaft from impeller B (Figure 4) on the oil pump.
- E. Remove the impellers A and B from the oil pump

3. Oil Pump Installation

- A. Lubricate all parts of the oil pump, the tachometer shaft, and other contact surfaces such as gear teeth and idler hubs with a mixture of 15% pre-lubricant and 85% SAE No. 50 mineral base aviation grade lubricating oil.
- B. Install impellers A and B in their respective compartments in the oil pump body (Figure 4).
- C. Install the oil pump drive shaft into the oil pump body and through impeller B (Figure 4).
- D. Install the oil pump over the mounting studs on the accessory housing.
- E. Install a washer and new slotted nut on each of the three studs on the accessory housing.
- F. While turning the oil pump drive shaft to ensure free movement of the impellers, torque the three slotted nuts gradually and evenly to 17 ft.-lb. (23 Nm),

NOTICE: If the oil pump drive gear assembly binds while tightening the slotted nuts, remove the oil pump, examine all parts of the oil pump for wear or damage. Replace worn or damaged parts if necessary and re-install the oil pump.

- G. Safety wire the three slotted nuts as shown in Figure 3.

- H. Look at the rear of the engine and note the position of the slots in the crankshaft gear.
- I. Turn the oil pump shaft to orient the tangs on the oil pump drive shaft to align with the slots in the crankshaft gear (Figure 5).

Slots in the Crankshaft Gear



Figure 5
Slots in the Crankshaft Gear

- 4. Fuel Pump Plunger Removal
Remove the fuel pump plunger from the accessory housing (Figure 6).
- 5. Fuel Pump Plunger Inspection
 - A. Clean the fuel pump plunger per instructions in Chapter 05-30.
 - B. Examine the fuel pump plunger for cracks or damage.
 - C. Replace a cracked or damaged fuel pump plunger.
- 6. Fuel Pump Plunger Installation
 - A. Apply a coat of Castrol® Moly Grease NLGI#1 or equivalent to approximately 1 in. (2.54 cm) of the plunger end and the head
 - B. Install the fuel pump plunger in the accessory housing as shown in Figure 6.
- 7. Accessory Housing Installation
 - A. Install the tachometer shaft seal (Figure 7).

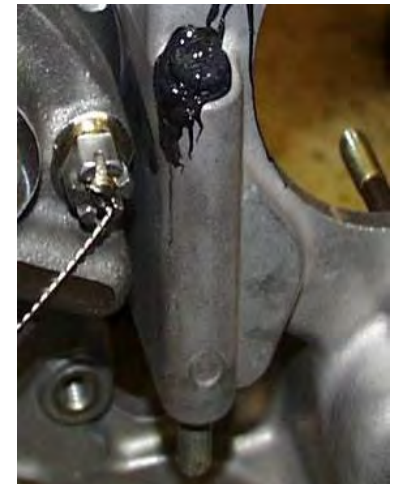


Figure 6
Fuel Pump Plunger

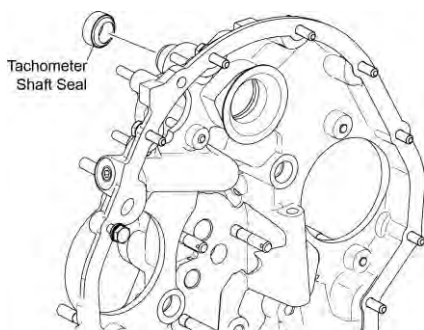


Figure 7
Tachometer Shaft Seal

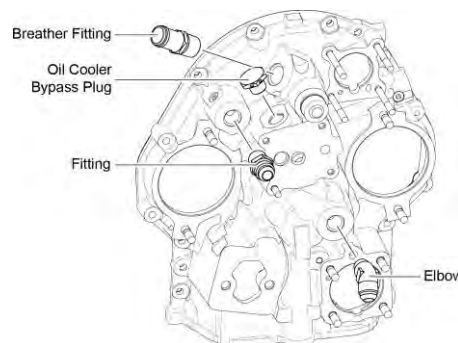


Figure 8
Plugs and Fittings
in Accessory Housing

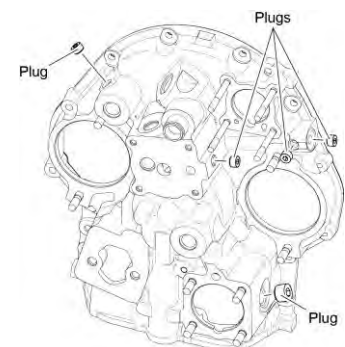


Figure 9
Plugs in Accessory Housing

- B. Apply engine oil mixture to the tachometer shaft seal.
- C. Examine plugs and fittings (Figures 8 and 9) for damage. Replace any damaged plug or fitting.
- D. Install fittings (Figure 8) in the accessory housing.
- E. Torque the fittings per the latest revision of the *Service Table of Limits - SSP-1776*.
- F. Install plugs in the accessory housing (Figure 9) with a new O-ring as required.
- G. Torque the plugs per the latest revision of the *Service Table of Limits - SSP-1776*.
- H. Turn the crankshaft to position cylinder 1 at TDC.
- I. Apply a light coat of Gasket Sealant #4 to the locations shown in Figure 10.

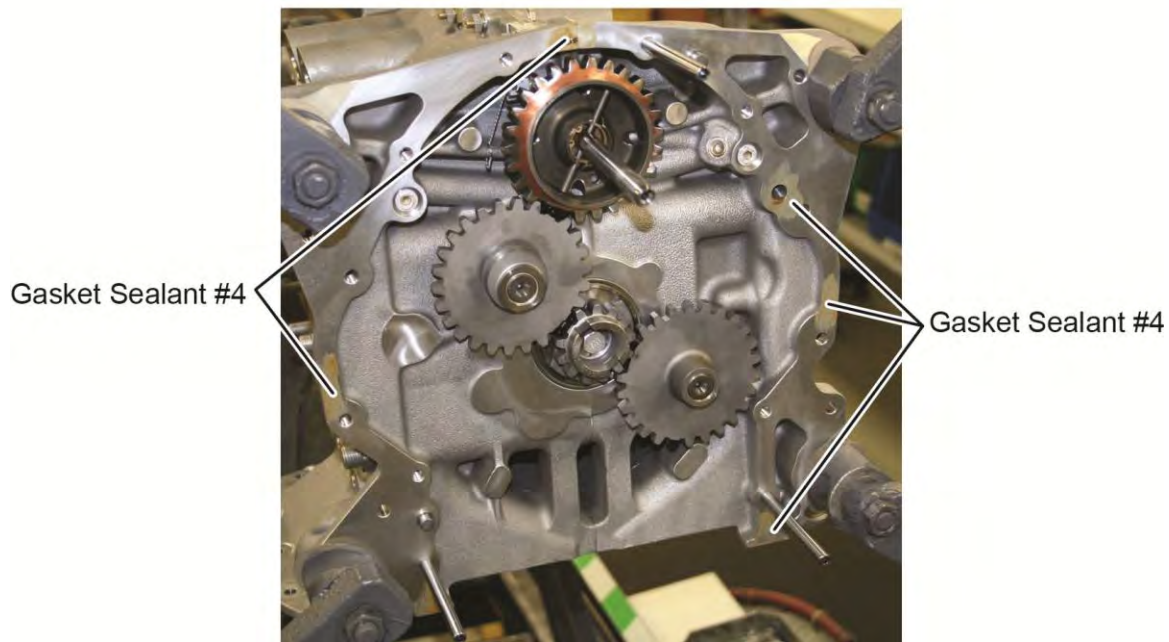


Figure 10
Gasket Sealant Locations

- J. Install a new accessory housing gasket (Figure 2) over the locating dowels on the rear of the crankcase.
- K. Apply a liberal coating of engine oil all contact surfaces, such as gear teeth and the idler gear hub.

NOTICE: When installing the accessory housing, if necessary, turn the crankshaft to enable the tangs on the oil pump drive shaft (Figure 4) to correctly align with the slots in the crankshaft gear (Figure 5).

- L. Fit the accessory housing into place on the rear of the crankcase.
- M. Install all Bolts A, B, and C with plain washers and new lock washers in the correct locations shown in Figure 1. Torque the bolts to 96 in.-lb. (11 Nm).

- N. On engines with a rear-mounted propeller governor drive, install the propeller gear drive adapter assembly per the “Propeller Governor Drive Installation” procedure in Chapter 72-60.
 - O. Install the vacuum pump driven gear per the “Vacuum Pump Driven Gear Installation” procedure in Chapter 72-60.
 - P. Install the vacuum pump per the “Vacuum Pump Installation” procedure in Chapter 72-60.
 - Q. Connect the hoses to the airframe-supplied oil cooler.
 - R. Install the fuel pump per instructions in Chapter 73-10.
 - S. Install any aircraft manufacturer installed accessories per instructions in the Aircraft Manufacturer’s Maintenance Manual.
 - T. Complete the “Oil Change Procedure” in Chapter 12-10 and install a new oil filter.
- NOTICE:** If your engine is equipped with a hydraulic pump, refer to Appendix A for hydraulic pump and hydraulic pump adapter assembly installation instructions.
8. Propeller Governor Replacement (Engines with Rear-Mounted Propeller Governor Drives)
Replace the propeller governor in accordance with the aircraft manufacturer’s instructions.

This page intentionally left blank.

72-30 - CYLINDER MAINTENANCE

1. General

- A. Complete the inspections identified in Table 1 at the regularly scheduled interval per instructions in this chapter.
- B. Record all findings and any corrective action on a copy of the respective Engine Inspection Checklists in Chapters 05-20 and in the checklists in this chapter as records of inspection.

Table 1
Regularly Scheduled Cylinder Inspections

Procedure	Frequency
Visual Cylinder Inspection	After every 100 hours of engine operation
Cylinder Compression Check	After every 100 hours of engine operation
Intercylinder Baffle Inspection	After every 100 hours of engine operation
Cylinder Borescope Inspection	After every 400 hours of engine operation
Exhaust Valve and Guide Inspection on IO-390-C engines	After every 1000 hours of engine operation*
* Half quantity of hours of engine operation for TBO	

2. Visual Cylinder Inspection

- A. Examine the cylinder and cylinder head (Figure 1) thoroughly for cracks, leaks, rust, pitting and/or damage. Replace a damaged, rusted, pitted, leaky or cracked cylinder per instructions in this chapter.
- B. Look for loose, damaged, or leaking crankcase thru-studs and cylinder hold-down studs. Replace with appropriate oversize studs per Appendix A. Refer to the latest revision of Service Instruction No. SI-1290 for additional information.
- C. Look for loose or damaged spark plug Heli-Coil® inserts. If a loose or damaged Heli-Coil® is found, replace the Heli-Coil® per the “Heli-coil® Replacement” procedure in this chapter.
- D. Look for cracked or broken fins and baffles (Figure 1). If a cooling fin adjacent to the exhaust port flange is cracked, a 3/16 in. diameter hole can be drilled as a stop, under the following conditions:
 - The end of the crack is at least 1/4 in. from the base of the metal; or
 - The cracked area can be removed from the fin, provided the maximum removal is no more than one-half the total fin width; or
 - No burrs or sharp edges are in evidence; or
 - The minimum fillet at the root of the removed portion of the fin has a 1/4 in. radius, and the minimum corner at the top of the fin adjacent to the removed portion has a 1/2 in. radius; or
 - There is no more than one crack per fin and its depth is not more than 1/4 in. from the base of the metal, and a fin stabilizer is used to reduce vibration and prevent further deepening of the crack.

- If a cooling fin is damaged, broken or bent, the bent area must not exceed 3/8 in. nor the break be 3/8 in. deep, or:
 - (1) There cannot be more than four blended fins on the push rod side of the head,
 - (2) No more than six blended fins on the anti-push rod side of the head.

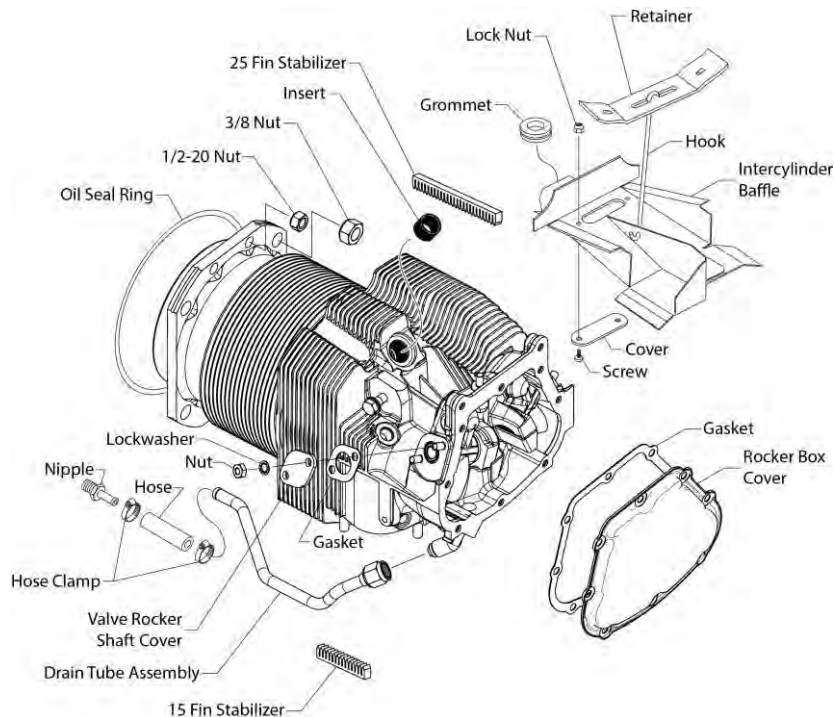


Figure 1
Engine Cylinder on IO-390-C Series Engines

3. Cylinder Compression Check

- A. The Cylinder Compression Check is done on an installed engine and measures pressure leakage through the combustion chamber using a regulated pressure source and tester. It is essentially a cylinder leak-check procedure as an initial inspection of the condition of the engine cylinders. This procedure compares the static leak rate of the cylinder with the leak rate through an orifice of a specified range.
- B. The Cylinder Compression Check on the engine cylinders must be done at the following times or if the engine has any of these conditions:
 - After every 100 hours of engine operation or annual inspection
 - Difficulty starting
 - Increased oil consumption
 - Loss of power or unsteady power
 - Other indications of unusual operation.

A differential compression tester (Figure 2), attached to pressure gages is used for the Cylinder Compression Check. This tester operates with a given airflow through a fixed orifice and measures constant pressure drop across that orifice. This Cylinder Compression Check identifies leaks caused by incorrect valve setting, worn piston rings, damaged pistons or damaged cylinders. The static leak rate can indicate the condition of the parts in the combustion chamber. The leak rate is measured when pressure drops.

NOTICE: The orifice size of the differential compression tester is critical for consistent and meaningful cylinder analysis. A specific orifice size of 0.040 in. diameter (No. 60 drill) x 0.250 in. long, with entrance angle of 59°/60° supplies an acceptable calibrated leak rate. Larger orifice sizes can decrease the effectiveness of identifying problems.

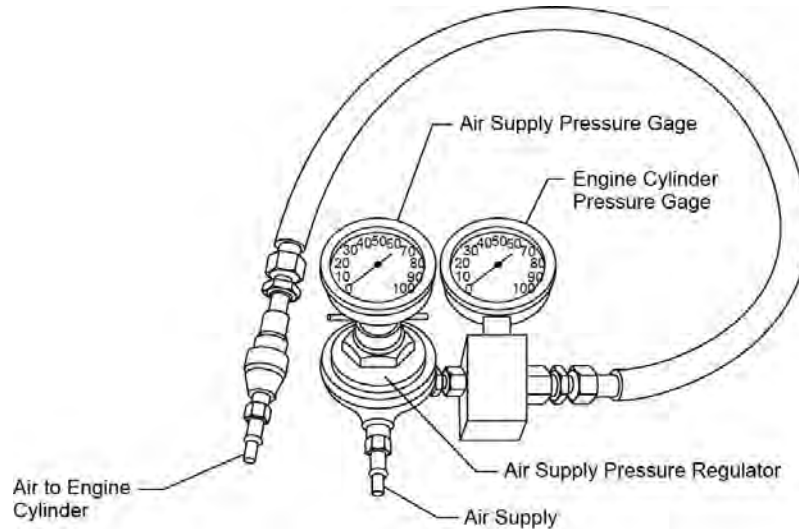


Figure 2
Example of a Differential Compression Tester

- (1) All differential compression testers must be in compliance with these specifications:
 - 0.250 in. long restrictor orifice
 - 0.040 in. ID (No. 61 drill) orifice diameter
 - 60° entrance angle
- (2) Make sure that all of the gages to be connected to the differential compression tester are calibrated in accordance with the differential compression tester's manufacturer's specifications.
- (3) Differential Compression Test Equipment Check:
 - (a) Close the shut-off valve.
 - (b) Make sure the regulated pressure is 80 psi (552 kPa).
 - (c) Make sure that the cylinder pressure gage shows 80 psi (± 2 psi) (552 kPa (± 14 kPa)), while it keeps the regulated pressure at 80 psi (552 kPa) for at least 5 seconds.
 - (d) If the differential compression tester fails this check, replace the tester.

C. Cylinder Compression Check Procedure

NOTICE: Make sure the differential compression tester has been calibrated and the equipment check is complete per previous steps before this cylinder compression check.

This check is to be done on an engine installed in the airframe or test stand without interruption while the cylinder is still warm.

- (1) Immediately before the Cylinder Compression Check:
 - (a) Operate the engine at usual cylinder head and oil temperatures (specified in Appendix A of the *IO-390-C Series Engine Installation and Operation Manual*).
 - (b) Put the power control in the IDLE CUT-OFF position.
 - (c) Move the ignition switch to the OFF position to shut down the engine.
 - (d) Make sure that the aircraft master switch and fuel supply switches are all in the OFF position.
 - (e) After the engine is shut down, complete the Cylinder Compression Check immediately to get an accurate measurement.
 - (f) Set the aircraft brakes and install the wheel chocks.

⚠ CAUTION: TAKE ALL NECESSARY PRECAUTIONS AGAINST ACCIDENTAL ROTATION OF THE CRANKSHAFT/PROPELLER TO PREVENT INJURY.

- (2) Disable power to the engine.

⚠ CAUTION: IGNITION LEADS AND SPARK PLUGS ARE VERY HOT. IN THE NEXT STEP, WEAR PERSONAL PROTECTIVE GEAR TO PREVENT BURNS.

- (3) Disconnect all of the spark plug leads per the “Spark Plug Removal” procedure in Chapter 74-20.

- (4) Remove the top spark plug from each cylinder.

⚠ CAUTION: USE GLOVES OR RAGS TO PROTECT HANDS WHILE HOLDING THE PROPELLER BLADE.

- (5) Turn the crankshaft by hand in the direction of propeller rotation to put the piston in a position as close to Top Dead Center (TDC) on the compression stroke as possible.
- (6) Install the threaded end of an adapter with a coupling end in the spark plug hole of the cylinder to be tested.
- (7) Make sure that the air valve on the differential compression tester is in the OPEN position.

⚠ CAUTION: BEFORE CONNECTION OF THE COMPRESSION TESTER, MAKE SURE THAT THE AIR SUPPLY REGULATOR DOES NOT SHOW MORE THAN 80 PSI (552 KPA) OF AIR PRESSURE. EXCESSIVE AIR PRESSURE CAN CAUSE THE PROPELLER TO TURN. KEEP CLEAR OF THE ROTATIONAL RADIUS OF THE PROPELLER.

- (8) Connect the differential compression tester to the adapter and to a clean source of compressed air.

NOTICE: Operate the differential compression tester per the manufacturer’s instructions.

- (9) Set the differential compression tester to approximately 100 to 120 psi (689 to 827 kPa).
- (10) Make sure that the engine cylinder pressure gage showed 80 psi (± 2 psi) (552 kPa (± 14 kPa)), while it keeps the regulated pressure at 80 psi (552 kPa) for at least 5 seconds.
- (11) One mechanic holds the propeller firmly in place, to prevent crankshaft rotation, while the other mechanic opens the cylinder pressure valve in the next step.

⚠ WARNING: IN THE NEXT STEP, HOLD THE PROPELLER FIRMLY WHEN OPENING THE AIR VALVE ON THE DIFFERENTIAL COMPRESSION TESTER. PENT-UP AIR PRESSURE IN THE CYLINDER COULD CAUSE THE CRANKSHAFT TO TURN.

- (12) Slowly open the air valve on the differential compression tester and increase the pressure to the cylinder to 15 to 20 psi (103 to 138 kPa).
- (13) Listen for escaping air. If escaping air is heard, refer to Table 2 to identify and correct the cause.
- (14) Continue to turn the propeller in the direction of rotation against the 15 to 20 psi (103 to 138 kPa) pressure until the piston reaches TDC evident by a sudden decrease in the force necessary to turn the propeller.

NOTICE: If you turn the propeller past TDC, back up the rotation at least one revolution and repeat this step to prevent backlash and to keep the piston rings in position. Then repeat the previous step to turn the propeller to TDC.

- (15) With the piston at TDC, one mechanic holds the propeller securely while the other mechanic opens the air valve slowly and completely. Gradually increase the air supply pressure up to 80 psi (552 kPa). As the pressure increases, the other mechanic must move the propeller back and forth slightly with a rocking motion to make sure that the piston rings are seated.
- (16) Record the pressure reading on the engine cylinder pressure gage. The difference between the engine cylinder pressure gage reading and the pressure shown on the air supply pressure gage reading is the amount of leakage through the cylinder.
- (17) The minimum approved engine cylinder pressure reading is 60 psi (414 kPa). Maximum approved leakage is 25% (20 psi (138 kPa) of the 80 psi (552 kPa) regulated pressure).
- (18) Close the air valve and disconnect the differential compression tester from the engine cylinder and connect it to the spark plug hole of the next engine cylinder to be tested.

NOTICE: Pressure readings for all of the engine cylinders are to be nearly equal. Refer to Table 2.

- (19) Complete the previous steps for each of the remaining engine cylinders.
 - (20) Refer to Table 2 for a summary of the Cylinder Compression Check results and corrective action. Corrective action in Table 2 applies to procedures in this chapter.
- D. Review and analyze the results. Take any necessary corrective action.
- E. Record the results of the Cylinder Compression Check for each cylinder on the 100-Hour Inspection Checklist in Chapter 05-20.
- F. After all service is complete, examine and install the spark plugs and connect the ignition leads to the spark plugs per the following procedures in Chapter 74-20.
- Spark Plug Inspection
 - Spark Plug Rotation
 - Ignition Harness Inspection
 - Spark Plug Installation
 - Spark Plug Gap Setting

Table 2
Summary of Cylinder Compression Check Results and Corrective Action

Results	Indication	Corrective Action
Differential pressure of 70 psi (483 kPa) or more for an engine cylinder	Satisfactory	No corrective action necessary.
Differential pressure of 61 to 69 psi (421 to 441 kPa) for an engine cylinder	Wear has occurred	Complete the Cylinder Compression Check again after the next 100-hour engine operating interval - record results. Monitor the differential pressure.
Differential pressure of 60 psi (414 kPa) or less for an engine cylinder	Cylinder worn or not in conformance	Either manually turn the crankshaft three times or start the engine and operate for 3 minutes and repeat the Cylinder Compression Check. If the results of the second Cylinder Compression Check are too low, listen for airflow at the exhaust and intake ports. Identify all of the causes and complete the necessary corrective action.
Difference of 5 psi (34 kPa) or less between engine cylinders (Pressure readings for all engine cylinders must be nearly equal.)	Satisfactory	No corrective action necessary.
Difference of 6 to 15 psi (41 to 103 kPa) between engine cylinders.		Repeat the Cylinder Compression Check after the next 10 hours of engine operation. A valve can reseat itself and show satisfactory compression again. If the difference remains between 6 to 15 psi (41 to 103 kPa) after the second Cylinder Compression Check, identify all of the causes and complete the necessary corrective action.
Difference of 15 psi (103 kPa) or more between engine cylinders		Start and operate the engine for 3 minutes and repeat the Cylinder Compression Check. If the difference between engine cylinders is still 15 psi (103 kPa) or more , replace all of the engine cylinders.
Air escaping at spark plug spot face	Fluorescent Penetrant Inspection of area shows cracks	Replace the cylinder with a cylinder kit.
Leak check at the spark plug port seals (using a soap solution) shows bubbling around spark plug port seal.	Heli-Coil [®] insert requires replacement.	Complete the "Heli-Coil [®] Replacement" procedure in this chapter.

**Table 2 (Cont.)
Summary of Cylinder Compression Check Results and Corrective Action**

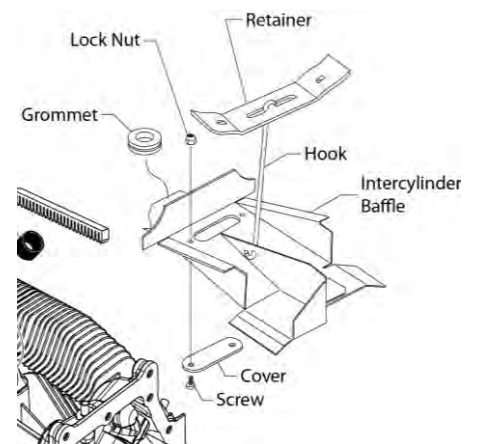
Results	Indication	Corrective Action
Air discharge at cylinder head to barrel juncture or between barrel fins.		Replace the cylinder with a cylinder kit.
Air discharged through the breather or oil filler tube.	Leakage in the area of the piston and rings.	Complete the “Piston Inspection” in this chapter.
Air discharged through the intake system	Cracked cylinder	Replace the cylinder with a cylinder kit.
	Intake valve and/or seat worn or burnt Leakage at the intake valve	Examine the intake valve and valve seat for wear or burns. Replace worn or burnt intake valve or intake valve seat.*
Air discharged through the exhaust system	Cracked cylinder	Replace the cylinder with a cylinder kit.
	Exhaust valve and/or seat worn or burnt Leakage at the exhaust valve	Examine the exhaust valve and valve seat for wear or burns.* Replace worn or burnt exhaust valve or exhaust valve seat.*
* Either replace the cylinder or send the engine cylinder to an authorized vendor to replace the valve seat.		

4. Intercylinder Baffle Inspection

A. This inspection is done during the 100-hour or annual inspections to look for premature cylinder deterioration and make sure that intercylinder baffles are correctly fitted and installed. The intercylinder baffles are necessary to prevent rapid deterioration of the cylinders and other engine components because they transfer heat in piston engines. To ensure this cooling, the intercylinder baffles must be installed intact and operating correctly.

B. Intercylinder Baffle Inspection Procedure

- (1) Examine the intercylinder baffle (Figure 3) and surrounding components for damage, holes, cracks, wear, deterioration, and incorrect position. Replace a damaged, worn, cracked or deteriorated intercylinder baffle per the “Intercylinder Baffle Removal” and Intercylinder Baffle Installation” procedures in this chapter.
- (2) Tighten any loose intercylinder baffle fasteners per the latest revision of the *Service Table of Limits SSP-1776*.
- (3) Correct the intercylinder baffle position as necessary.
- (4) Record results of this inspection and any corrective action taken on the 100-Hour Inspection Checklist in Chapter 05-20.



**Figure 3
Intercylinder Baffle**

5. Cylinder Borescope Inspection

⚠ WARNING: DURING A CYLINDER BORESCOPE INSPECTION, MAKE SURE THAT THE IGNITION SWITCH IS TURNED OFF AND THAT POWER TO THE ENGINE IS DISCONNECTED.

AS A PRECAUTION, DO NOT STAND OR ALLOW ANYONE TO STAND WITHIN THE ROTATIONAL ARC RADIUS OF THE PROPELLER. MAKE SURE THE ENGINE IS COOL.

- A. The cylinder borescope inspection is done to examine the inner walls of the engine cylinders for rust, deposits and unusual wear patterns of the combustion chamber, valve, piston top, and the cylinder barrel.
- B. When to complete the Cylinder Borescope Inspection:
 - (1) Before engine cylinder removal
 - (2) If oil consumption is excessive
 - (3) 100-hour or annual inspection
 - (4) After an engine overspeed
 - (5) Low compression
- C. Cylinder Borescope Inspection Procedure
 - (1) Remove a spark plug from each cylinder per the “Spark Plug Removal” procedure in Chapter 74-20.
 - (2) Put the piston at bottom dead center on the power stroke.
 - (3) Install the borescope through the vacant spark plug hole on the engine cylinder and examine the combustion chamber, the top of the piston, the internal surfaces of each cylinder, including the exhaust valve and exhaust valve seat. Complete inspection steps in Table 3.
 - (4) Remove the borescope from the cylinder.
 - (5) Put the piston at bottom dead center at the end of the intake stroke.
 - (6) Install the borescope through the vacant spark plug hole and examine the intake valve and intake valve seat. Complete inspection steps in Table 3. Corrective action in Table 3 applies to procedures in this chapter.
 - (7) Reinstall the spark plug in the cylinder per the “Spark Plug Installation” procedure in Chapter 74-20.
 - (8) Record all results and corrective action in the 100-Hour or Annual Inspection Checklist in Chapter 05-20.

Table 3
Borescope Inspection Steps, Results and Corrective Action

Inspection Step	If these are the results...	Take this corrective action...
Examine valve seat inserts for scoring, pitting, erosion, burning or damage	Eroded, scored, burnt, pitted or damaged valve seats	Replace the cylinder or send the engine cylinder to an authorized vendor to replace the valve guide.
Examine spark plug Heli-Coils® for protrusion into the combustion chamber	Spark plug Heli-Coil® protrudes into combustion chamber	Replace the Heli-Coil® per the “Heli-Coil® Replacement” procedure in this chapter.
Look for discoloration on the circumference of the exhaust valve face	Discoloration on the circumference of the exhaust valve face	Remove and examine the exhaust valve.
Look for cracks and erosion on the exhaust valve face	Cracks or erosion on the exhaust valve face	Remove and examine the exhaust valve.
Look for discoloration on the circumference of the intake valve face	Discoloration on the circumference of the intake valve face	Remove and examine the intake valve.
Look for cracks and erosion on the intake valve face	Cracks or erosion on the intake valve face	Replace the intake valve.
Examine the cylinder bore for scoring, rubbing, or corrosion	Scoring or piston rub or corrosion on cylinder bore	Remove and examine the engine cylinder.
Look for excessive oil in the cylinder	Excessive oil in the cylinder	Remove and examine the engine cylinder. Remove and examine the suction screen and oil filter/pressure screen per Chapter 12-10.
Examine the piston crown for erosion or damage	Erosion or damage on piston crown	Remove the engine cylinder and examine the piston.

6. Exhaust Valve and Guide Inspection

On IO-390-C engines, this inspection is to be done after every 1000 hours of engine operation or earlier if valve sticking is suspected.

NOTICE: If valve sticking is a problem, this inspection must be done every 400 hours. Refer to “Corrective Action for Valve Sticking” in this chapter.

Sticking between the valve stem and guide (on intake and exhaust valves) can substantially change valve opening and closing. If the valve cannot open or close correctly, incomplete combustion will occur, which can cause formation of more deposits and increased valve sticking. Because a correctly-timed sequence of valve opening and closing is essential to efficient and reliable engine operation, the cause of valve sticking must be identified and corrected.

 WARNING: A STUCK VALVE CAN CAUSE ENGINE DAMAGE.

NOTICE: If one valve is sticking, examine all intake and exhaust valves on all of the engine cylinders.

The exhaust valve and guide must be examined to measure valve stem movement to identify excessive wear (bell-mouthing) of the exhaust valve guide and carbon build-up between the valve guide and valve stem which can cause valve sticking

Refer to the latest revision of Service Bulletin No. SB-388, Service Instruction No. SI-1485, and Service Letter L197 for additional details.

NOTICE: The Gage (ST-310) is used to examine angular-type valves on engine cylinders. Although Gage (ST-310) and a feeler gage can be used to measure valve stem movement, a modified Gage (ST-310) (Figure 4) and a dial indicator are a faster and easier means to measure valve stem movement, valve guide wear, and carbon build-up per this procedure.

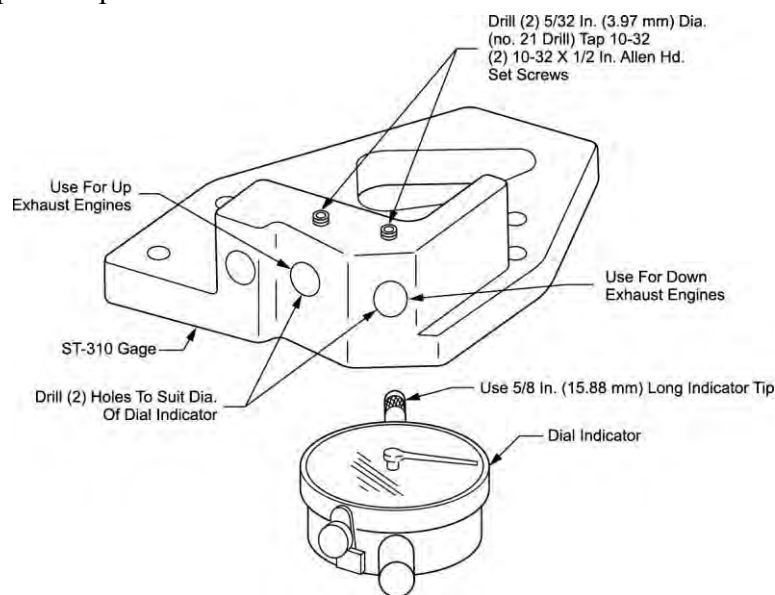


Figure 4
Details for Modifying Tool P/N ST-310

NOTICE: Do not intermix valve and cylinder components between cylinders. Re-install serviceable parts in the same cylinder.

A. Examine the exhaust valve and guide on each cylinder as follows:

- (1) Disable all power to the engine.
- (2) Make sure the engine is cool.

NOTICE: A silicone rocker box cover gasket can be reused if it is not damaged.

- (3) Remove the screws, rocker box cover (Figure 5) and gasket from the cylinder head. Discard the gasket.
- (4) Remove the nuts, lock washers, rocker shaft cover, and rocker shaft cover gasket. Discard the lock washers and rocker shaft cover gasket.
- (5) Remove the valve rocker shaft, valve rocker shaft bushing, rocker assembly, and washer.
- (6) Remove the valve stem cap from the exhaust valve.

- (7) Remove and examine the valve stem keys which tend to wear in uniform distinctive patterns. Replace worn or damaged valve stem keys. If the keys do not need to be replaced, install them in the same position from where they were removed.

⚠ CAUTION: DO NOT MIX PLUNGER ASSEMBLIES WITH DIFFERENT PART NUMBERS IN THE SAME ENGINE. DIFFERENT PLUNGERS HAVE VARYING LEAK DOWN RATES WHICH CAN CAUSE INCORRECT ENGINE OPERATION.

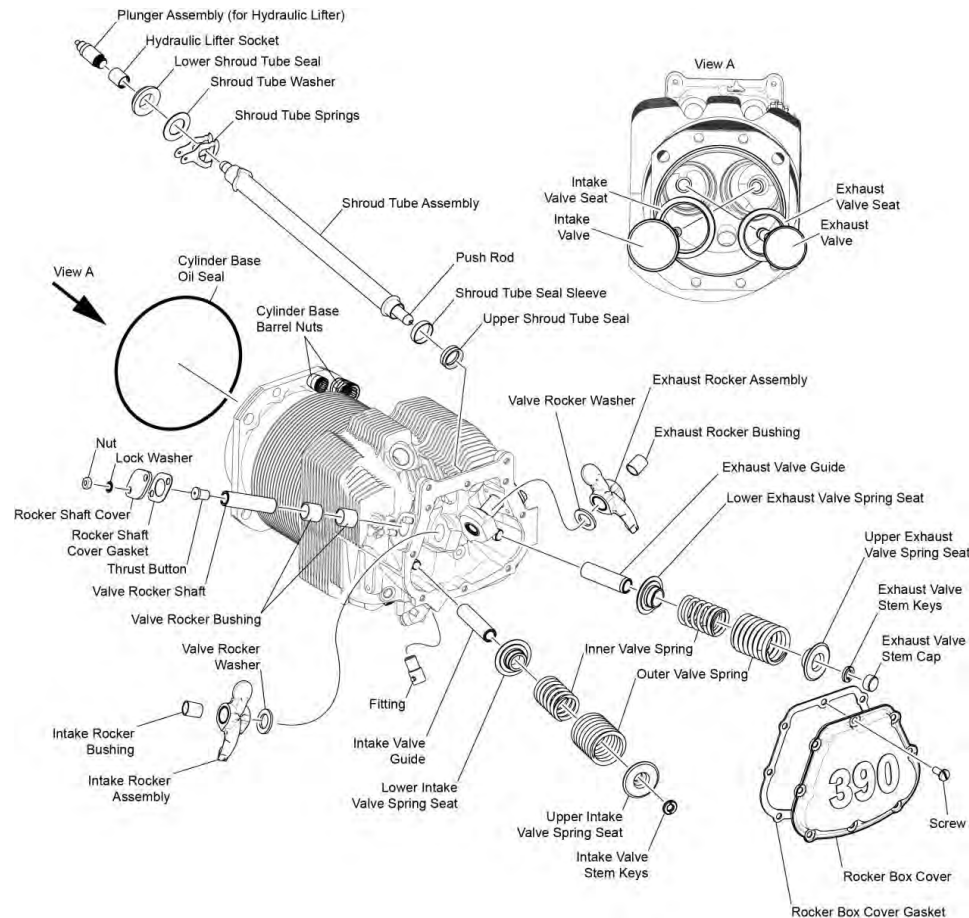


Figure 5
IO-390-C Series Engine Valve Components

- (8) Remove all of the push rods, shroud tubes, hydraulic lifter sockets, plunger assemblies, sleeve, shroud tube springs, washers, and upper and lower shroud tube seals from the engine cylinder. Discard the shroud tube seals.

NOTICE: Do not confuse “valve spring seats” with “valve seats,” valve spring seats (Figure 5) are metal disks installed on the ends of the valve springs in the rocker box and are field replaceable. Valve seats (Figure 5, View A) are installed inside the cylinder as the surface where the intake or exhaust valve rests during engine operation when that valve is closed. Valve seats only can be replaced by an authorized vendor.

- (9) Use a cloth dampened with mineral spirits to wipe the oil from the top surface of the upper exhaust valve spring seat on the exhaust valve (Figure 5).

- (10) Loosen the screws identified in Figure 6 to prevent the screws from touching the Gage Adapter (ST-310-9) when installed on the valve stem.
- (11) Install the Gage (ST-310) on the valve on the cylinder head as shown in Figure 6.
- (12) Tighten the cap screws (identified in Figure 6) equally. If the casting touches the lower cap screw, put the washer under the head.
- (13) Measure stem movements by moving the valve stem along the valve guide wear line (inside diameter of the valve guide, parallel to the centerline of the valve rocker arm).

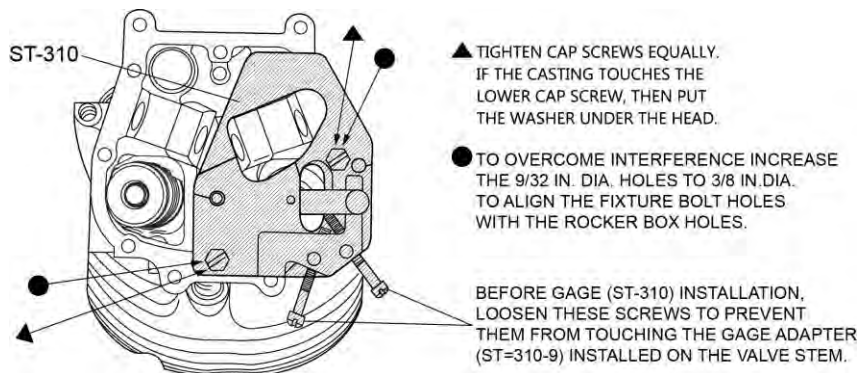


Figure 6
Gage ST-310 Installation on the Cylinder Head

- (14) Install the Gage Adapter (ST-310-9) over the top of the valve stem (Figure 7). Make sure it is tight.

NOTICE: If you can move the Gage Adapter (ST-310-9) on the valve stem with your hand, it is incorrectly installed.

- (15) Push the valve stem and Gage Adapter (ST-310-9), against the upper exhaust valve spring seat as far as they will go.
- (16) Put the blade of a screwdriver in the area between the exhaust valve spring and Gage (ST-310).

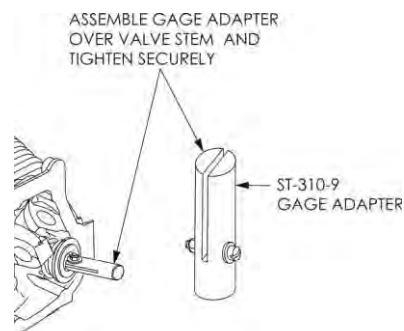


Figure 7
Gage Adapter (ST-310-9)
Assembled on Exhaust System

- (17) Use the screwdriver to push the valve and adapter the maximum distance away from the dial indicator as shown in Figure 8.
- (18) Move the dial indicator toward the adapter post until the indicator is preloaded approximately 0.010 in. (0.254 mm), and lock it in place with the set screw.
- (19) Adjust the dial of the indicator to read "0" (zero).

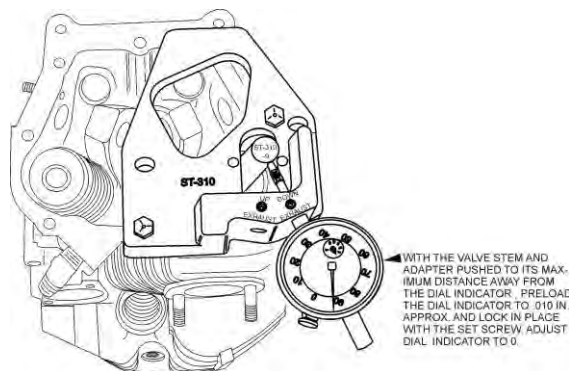


Figure 8
Dial Indicator

- (20) Insert the screwdriver between the Gage (ST-310) and valve spring on the opposite side and push the valve spring toward the dial indicator as shown in Figure 9.
- (21) Relax the screwdriver and record the reading on the dial indicator. For the exhaust valve guide to be acceptable, the measurement must be within the specified limits in latest revision of the ***Service Table of Limits - SSP-1776***.
- (22) If the exhaust valve guide is out of tolerance either replace the cylinder or send the cylinder to an authorized vendor who can replace the valve guide.
- (23) Move the piston to near its top end of travel.
- (24) Remove the Gage Adapter (ST-310-9) from the valve stem.
- (25) Loosen each cap screw in the Gage (ST-310) (Figure 6) in small equal increments to decrease pressure on the valve spring slowly and equally.
- (26) Remove the Gage (ST-310) from the cylinder.
- (27) Repeat this exhaust valve and guide inspection for all cylinders.
- (28) Record all of the results in the 1000-Hour Inspection Checklist for IO-390-C Series engines (Chapter 05-20).

⚠ CAUTION: DO NOT MIX PLUNGER ASSEMBLIES WITH DIFFERENT PART NUMBERS IN THE SAME ENGINE. DIFFERENT PLUNGERS HAVE VARYING LEAK DOWN RATES WHICH CAN CAUSE INCORRECT ENGINE OPERATION.

- (29) If removed, examine and install acceptable plunger assemblies and hydraulic lifter sockets in the correct location. Refer to the latest revision of Service Instruction SI-1011 for plunger assembly inspection guidelines.
- (30) Install all of the seals, washers, sleeve, springs, shroud tubes, and push rods (Figure 5) on the cylinder.

NOTICE: The valve stem cap is only on the exhaust valve stem.

- (31) Install the valve stem cap (Figure 10) on the exhaust valve stem.
- (32) Install the rocker assembly, valve rocker shaft bushing, washer, and valve rocker shaft (Figure 5).

AFTER THE DIAL INDICATOR HAS BEEN PRELOADED USE A SCREWDRIVER TO MOVE VALVE STEM TOWARD DIAL INDICATOR. RELAX PRESSURE ON SCREWDRIVER AND RECORD INDICATOR READING. INDICATOR READING MUST BE WITHIN LIMITS SHOWN IN TABLE.

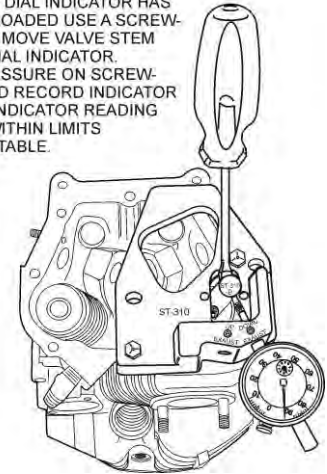


Figure 9
Pushing Valve Stem and Adapter Post Toward Dial Indicator

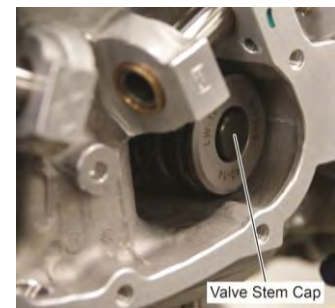


Figure 10
Exhaust Valve Stem Cap

- (33) Install the valve rocker shaft cover with a new valve rocker shaft cover gasket with new lock washers and nuts. Torque the nuts to 96 in.-lb. (11 Nm).
- (34) Install the screws, rocker box cover with a new gasket on the cylinder head (Figure 5). Torque the screws per the Special Torque Requirements Table in the latest revision of the *Service Table of Limits - SSP-1776*.
- (35) Enable power to the engine.
- (36) Complete the “Operational Ground Check” in Chapter 72-00.

7. Cylinder Removal

- A. Disable all power to the engine and disconnect the engine ignition harness from the airframe.
- B. If not already done:

<ul style="list-style-type: none"> • Remove airframe components to enable cylinder removal 	Airframe Maintenance Manual
<ul style="list-style-type: none"> • Drain the oil from the oil sump. • Disconnect the ignition leads to the spark plugs. Remove the top and bottom spark plugs from the cylinder. 	<p>“Oil Change Procedure” in Chapter 12-10</p> <p>“Spark Plug Removal” procedure in Chapter 74-20.</p>
<ul style="list-style-type: none"> • Remove the intake and exhaust pipes from the cylinder to be removed. 	<p>“Intake Pipe Removal” procedure in Chapter 72-80 and the airframe manufacturer’s instructions.</p>
<ul style="list-style-type: none"> • Remove the clamps that attach the fuel line to the shroud tube, disconnect the fuel line from the injection nozzle (Figure 11), put a cap on the end of the fuel line and the injection nozzle. 	

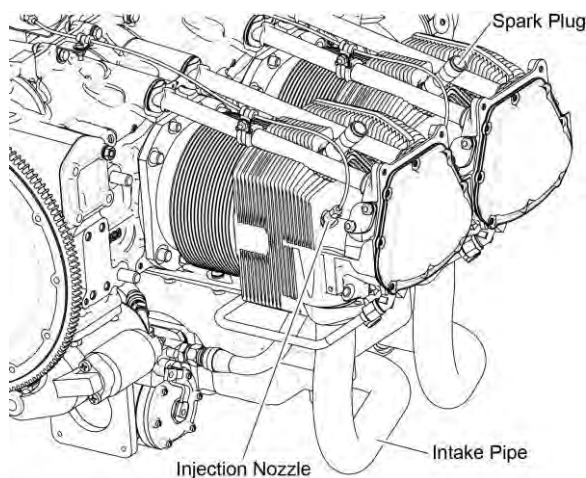


Figure 11
Spark Plugs, Intake Pipes,
and Injection Nozzles

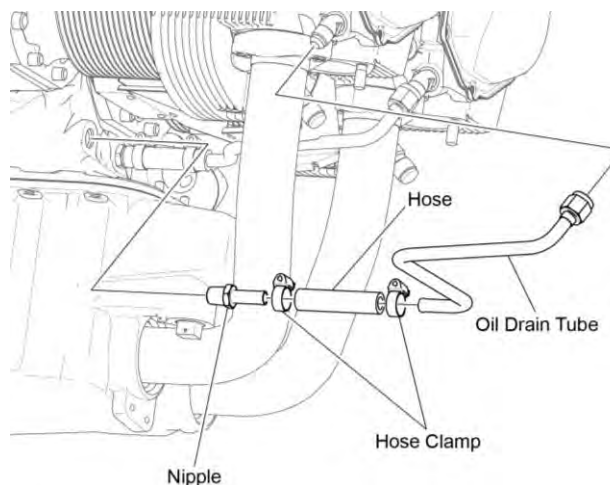


Figure 12
Oil Drain Tube

C. Oil Drain Tube Removal

NOTICE: There are different part numbers for some of the oil drain tube assemblies. Apply a label to identify the location of each oil drain tube, in case the drain tube is to be replaced. Refer to the applicable parts catalog for the correct part number for the oil drain tube.

- (1) Remove the hose clamps (Figure 12) from the hose attached to the drain tube assembly.
- (2) Disconnect the hose from the nipple.
- (3) Disconnect the drain tube fitting from the engine cylinder.
- (4) Remove and discard the hose.
- (5) Remove the drain tube assembly from the cylinder.
- (6) Examine the drain tube for cracks or damage.
- (7) Replace a cracked or damaged drain tube assembly.

NOTICE: Remove the cylinders by firing order 1-3-2-4 (Figure 13). Remove each cylinder as an assembly.

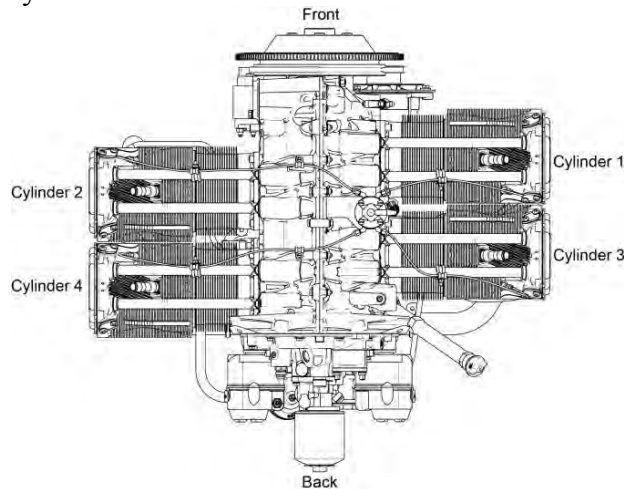


Figure 13
Engine Cylinder Firing Order

NOTICE: During cylinder removal, identify and label the cylinder, piston, and other parts by location (i.e., cylinder number) as they are removed for reference on assembly (to ensure that each part is installed in the same location from which it was removed).

D. Intercylinder Baffle Removal

- (1) Turn the baffle retainer hook to disengage the retainer on the intercylinder baffle (Figure 14).
- (2) Remove the intercylinder baffle and hook from between the cylinders.

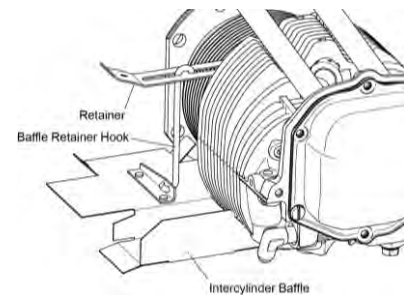


Figure 14
Intercylinder Baffles

- E. Remove the screws from the rocker box cover (Figure 15).
- NOTICE:** A silicone rocker box cover gasket can be reused if it is not damaged.
- F. Remove the rocker box cover and gasket. Discard the gasket.
- G. Remove the nuts and lock washers from the rocker shaft covers. Discard the lock washers.
- H. Remove the rocker shaft cover, and rocker shaft cover gasket. Discard the gasket.

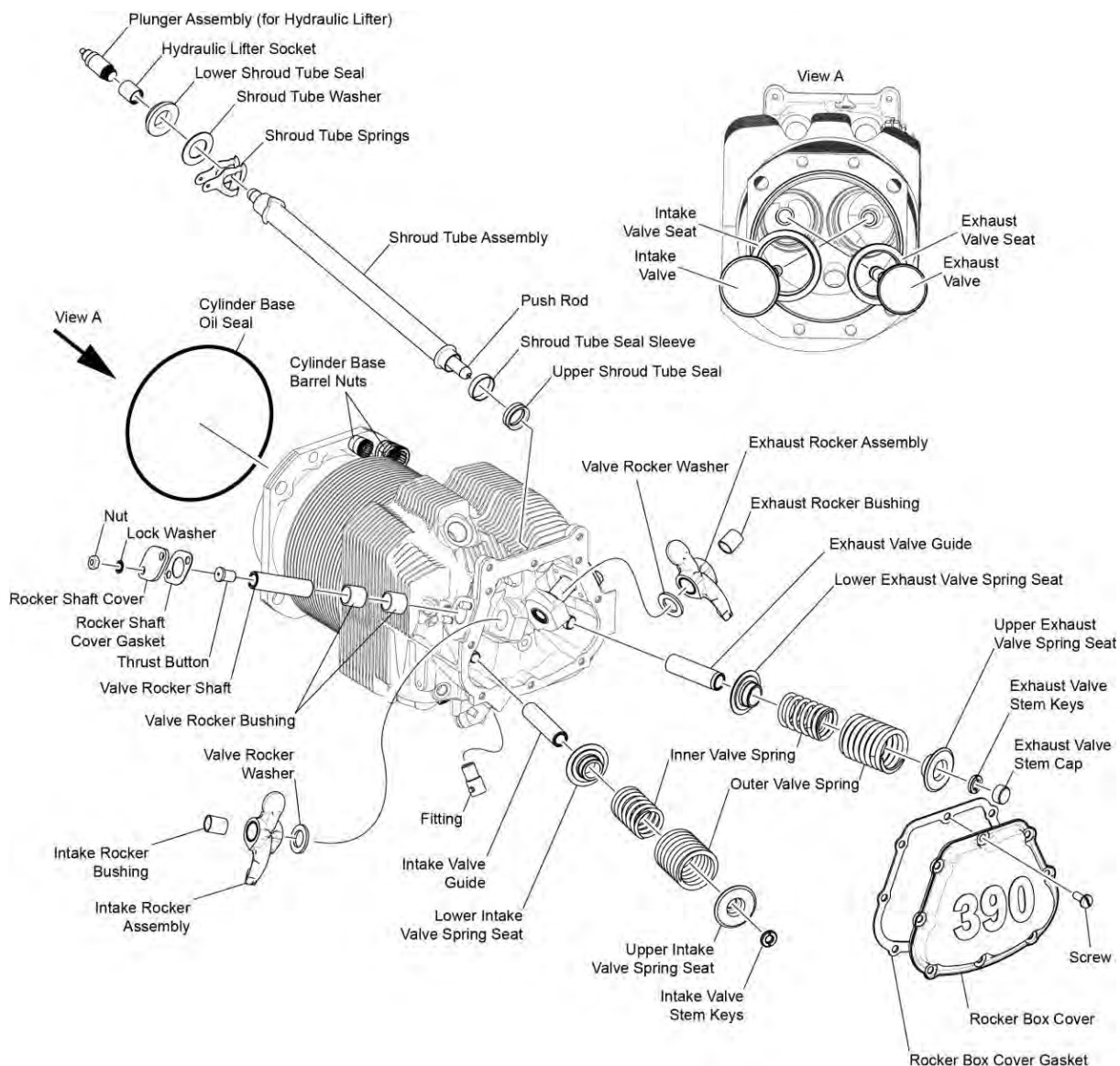


Figure 15
IO-390-C Series Engine Valve Components

- I. Turn the crankshaft to put the piston at TDC of the compression stroke of the cylinder to be removed. (With the piston in this position, both intake and exhaust valves are closed and the piston is extended away from the crankcase to prevent damage when the cylinder is removed.)

NOTICE: There is a different rocker assembly (Figure 15) for the intake and exhaust side of the engine cylinder. Identify whether the rocker assembly is from the intake or exhaust side for reference on cylinder assembly.

Do not remove the valve rocker shaft until the cylinder is removed from the engine.

- J. Push the valve rocker shafts (Figure 15) outward and remove the rocker assemblies and bushings.
- K. Remove the push rods and the valve stem cap from the exhaust valve.
- L. Using the shroud tube wrench (ST-142), turn each shroud tube 90° in either direction to release the tube from the spring.
- M. Remove the shroud tubes by first releasing them from the seal seats in the cylinder head and withdrawing the tubes.
- N. Remove the seals from the ends of the shroud tubes. Discard the seals.
- O. Compress the valve springs with a Valve Spring Compressor Tool (ST-25) and remove the valve stem keys.
- P. Remove the valve spring seats and valve springs.
- Q. Remove the cylinder base hold-down barrel nuts (Figure 16).

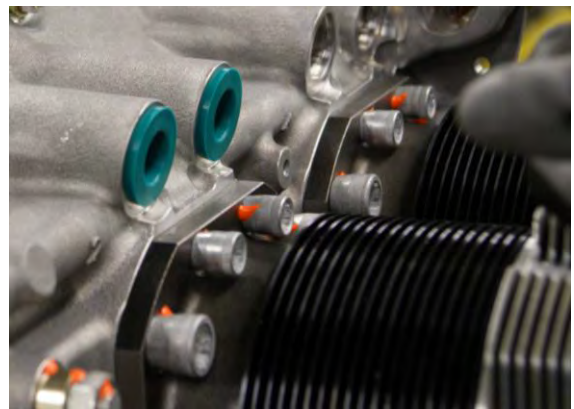


Figure 16
Cylinder Hold-Down Barrel Nuts

⚠ CAUTION: AS EACH CYLINDER IS SEPARATED FROM THE CRANKCASE, CATCH AND HOLD THE PISTON TO PREVENT IT FROM FALLING AGAINST THE CRANKCASE AND BEING DAMAGED.

- R. Remove the cylinder from the engine.
- S. Remove the cylinder base oil ring from the cylinder (Figure 17) and keep it to use as support for the connecting rods after the pistons are removed.
- T. Remove the valve rocker shaft (Figure 15) from the engine cylinder.

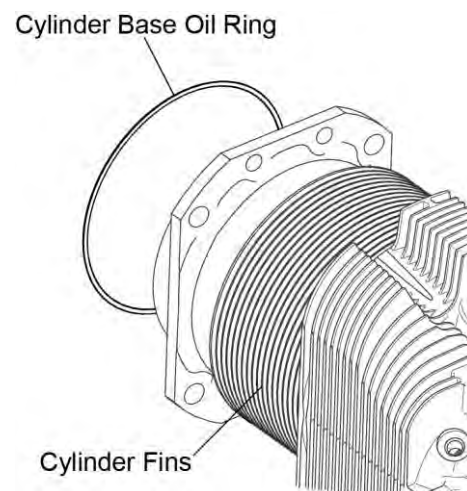


Figure 17
Cylinder Base Oil Ring and Cylinder Fins

8. Piston Removal

NOTICE: During removal of each piston pin (Figure 18), the piston will disconnect from the connecting rod.

- A. Support the piston and remove the two piston pin plugs (Figure 18) and piston pin from the piston.

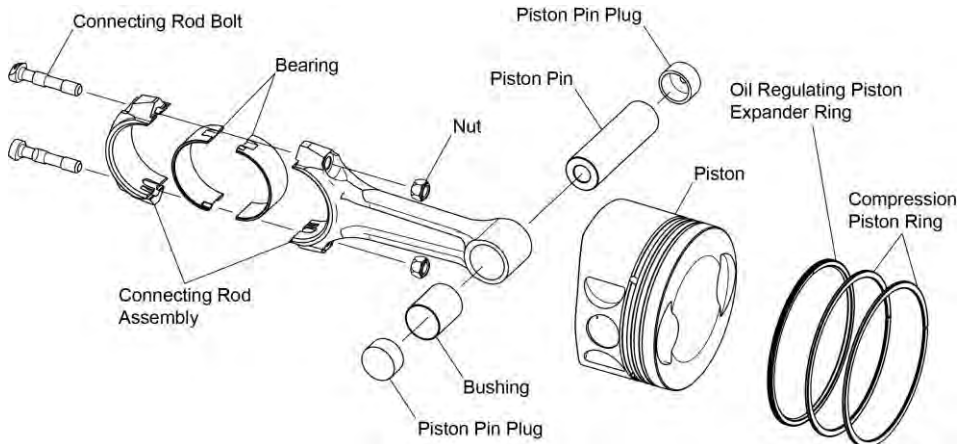


Figure 18
Piston Assembly

- B. During piston removal, support the connecting rod one of two ways to prevent damage to the connecting rods and crankcase:
 - (1) Install Torque Hold-Down Plates (ST-222) as shown in Figure 19.
 - OR
 - (2) Make a loop around the cylinder base studs and connecting rod using a rubber band or the cylinder base seal (removed during cylinder removal) as shown in Figure 20.

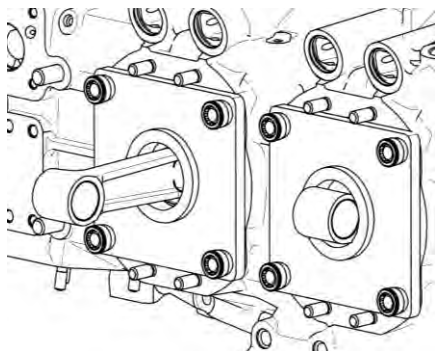


Figure 19
Torque Hold-Down Plates (ST-222)

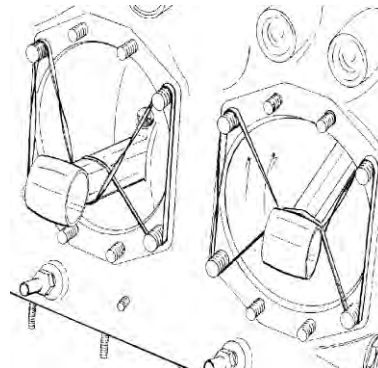


Figure 20
Loop Cylinder Base Oil Seal Around Cylinder Base Studs and on Connecting Rods

- C. Remove the piston from the connecting rod.

CAUTION: DURING REMOVAL OF THE THREE PISTON RINGS IN THE NEXT STEP, USE CARE NOT TO SCRATCH THE PISTON.

- D. Start from the top down, use the a commercially available piston ring expander tool to remove the two top compression rings and the oil regulating piston expander ring (Figure 18).

9. Cylinder Assembly Inspection

Copy and complete the Cylinder Assembly Inspection Checklist.

Cylinder Assembly Inspection Checklist

Engine Model Number: _____ Engine Serial Number: _____		
Engine Hours: _____ Inspection Date: _____		
Item to Examine and Corrective Action	Cylinder No.	Findings / Corrective Action
Look for wear or broken parts in the area of the valve, springs, and spring seats. Corrective Action: Replace the cylinder or send the engine cylinder to an authorized vendor to replace all loose, scored, pitted, defective, or damaged valve seats (Figure 15).	Cylinder 1	
	Cylinder 2	
	Cylinder 3	
	Cylinder 4	
Examine the intake and exhaust valve seats for looseness, scoring, pitting damage or non-conformities. Look for cracked or eroded valve seat bores. Corrective Action: Replace the cylinder or send the engine cylinder to an authorized vendor to replace the valve seats.	Cylinder 1	
	Cylinder 2	
	Cylinder 3	
	Cylinder 4	
Examine intake and exhaust valve guides for looseness, cracks or scoring. Corrective Action: If the valve guide is loose, scored, pitted, defective, or damaged, replace the cylinder or send the cylinder to an authorized vendor who can replace the valve guide.	Cylinder 1	
	Cylinder 2	
	Cylinder 3	
	Cylinder 4	
Look for rust/pitting on: Cylinder barrel fins and fin tips in power stroke areas Cylinder barrel and base flange Corrective Action: Replace the cylinder if rust/pitting is found <u>Do not grind the cylinder bore</u> to remove pitting or damage caused by overheating.	Cylinder 1	
	Cylinder 2	
	Cylinder 3	
	Cylinder 4	

Cylinder Assembly Inspection Checklist (Cont.)

Item to Examine and Corrective Action	Cylinder No.	Findings / Corrective Action
<p>Look for discolored/burnt paint or scored cylinder barrel bores. Look for blistered paint on the cylinder barrel.</p> <p>Corrective Action: Replace the cylinder if the cylinder barrel bores are scored or if the paint is discolored/burnt/ blistered.</p>	Cylinder 1	
	Cylinder 2	
	Cylinder 3	
	Cylinder 4	
<p>Examine the threads in all threaded holes in the cylinder for debris or damage.</p> <p>Corrective Action: Use the correct size bottoming tap to clean the threads. If thread damage cannot be corrected with the tap, replace the cylinder.</p>	Cylinder 1	
	Cylinder 2	
	Cylinder 3	
	Cylinder 4	
<p>Examine the exhaust flange for damage or warping.</p> <p>Corrective Action: Replace the cylinder if the exhaust flange is warped or damaged.</p> <p><u>Do not grind or repair the exhaust flange</u> to correct a bent or warped flange.</p>	Cylinder 1	
	Cylinder 2	
	Cylinder 3	
	Cylinder 4	
<p>Look for any radial fin crack extending to the root of a fin.</p> <p>Corrective Action: Replace the cylinder if there is a radial fin crack extending to the root of the fin.</p>	Cylinder 1	
	Cylinder 2	
	Cylinder 3	
	Cylinder 4	

Cylinder Assembly Inspection Checklist (Cont.)

Item to Examine and Corrective Action	Cylinder No.	Findings / Corrective Action
Look for broken, bent or straightened, or pitted cylinder head fins. Refer to the “Visual Cylinder Inspection” in this chapter. Corrective Action: Replace any cylinder that has unacceptable cylinder head fins.	Cylinder 1	
	Cylinder 2	
	Cylinder 3	
	Cylinder 4	
Look for cracks in the cylinder head. Measure the diameter of the cylinder head at several points to identify any out-of-roundness. Refer to the latest revision of the <i>Service Table of Limits - SSP-1776</i> for measurements. Corrective Action: Replace any cylinder that has a crack in the cylinder head or if the cylinder head is out-of-round.	Cylinder 1	
	Cylinder 2	
	Cylinder 3	
	Cylinder 4	
Look for static seal leakage or leakage from the head-to-barrel seal or crack in the head or barrel. Corrective Action: Replace any cylinder that has leakage at the cylinder head or barrel.	Cylinder 1	
	Cylinder 2	
	Cylinder 3	
	Cylinder 4	
Look for scratches in the honed surface of the cylinder wall or cylinder bore. Corrective Action: Hone the cylinder to remove the scratches. Refer to the latest revision of the <i>Service Table of Limits - SSP 1776</i> for dimensions and limits.	Cylinder 1	
	Cylinder 2	
	Cylinder 3	
	Cylinder 4	
Make sure there is not any cylinder head-to-barrel flange movement. Corrective Action: Replace any cylinder that has any cylinder head-to-barrel flange movement.	Cylinder 1	
	Cylinder 2	
	Cylinder 3	
	Cylinder 4	

Cylinder Assembly Inspection Checklist (Cont.)

Item to Examine and Corrective Action	Cylinder No.	Findings / Corrective Action
Examine mounting pads (for intake and exhaust ports) for nicks, scoring or dents. Corrective Action: Replace all nicked, scored, or dented mounting pads for intake and exhaust ports.	Cylinder 1	
	Cylinder 2	
	Cylinder 3	
	Cylinder 4	
Examine mounting pads for rocker box covers for nicks, scoring or dents. Corrective Action: Replace all nicked, scored, or dented mounting pads for rocker box covers.	Cylinder 1	
	Cylinder 2	
	Cylinder 3	
	Cylinder 4	
Examine the spark plug Heli-Coil [®] inserts for looseness or damage. Corrective Action: Replace all loose or damaged spark plug Heli-Coil [®] inserts with oversize inserts per the “Heli-Coil [®] Replacement” procedure in this chapter.	Cylinder 1	
	Cylinder 2	
	Cylinder 3	
	Cylinder 4	
Examine studs on the cylinder head for looseness or damage. Corrective Action: Replace all loose or damaged studs with the next higher applicable oversize studs.	Cylinder 1	
	Cylinder 2	
	Cylinder 3	
	Cylinder 4	
Measure the inside diameter of the rocker shaft bushings. Refer to the latest revision of the <i>Service Table of Limits - SSP 1776</i> for dimensions. Corrective Action: Replace the rocker shaft bushings if they are not in accordance with specifications.	Cylinder 1	
	Cylinder 2	
	Cylinder 3	
	Cylinder 4	

10. Piston Inspection

A. Copy and complete the Piston Inspection Checklist.

- (1) Examine the entire piston for damage or discoloration from burns.
- (2) Examine the piston grooves for wear. Measure the piston ring clearance and compare to measurements in the latest revision of the *Service Table of Limits - SSP-1776*.

Piston Inspection Checklist

Engine Model Number: _____ Engine Serial Number: _____	
Engine Hours: _____ Inspection Date: _____	
Inspection Item	Findings/Corrective Action
<p>Before cleaning the piston, examine the following areas on the piston for pitting, cavities and surface distortion (which can be an indication of detonation or pre-ignition):</p> <ul style="list-style-type: none"> • Top of the piston • Piston ring lands and grooves • Piston pin holes • Piston pin whole bosses • Look for deposits or damage <p>Complete the “Piston Cleaning” procedure in Chapter 05-30.</p> <p>NOTICE: Surface distortion can be an indication of detonation or pre-ignition.</p>	Cylinder 1
	Cylinder 2
	Cylinder 3
	Cylinder 4
<p>After Cleaning:</p> <ul style="list-style-type: none"> • Look for cracks on the piston head or skirt. Replace the piston if a crack is found. • Look for bent or broken lands. Replace the piston if the land is broken or bent. • Look for scoring on the piston skirt, damage or discoloration from burns. Replace the piston if scoring, damage or discoloration found. Identify and correct the cause. • Examine the piston grooves for wear. Replace the piston if high ridges are on the lower lands.* 	Cylinder 1
	Cylinder 2
	Cylinder 3
	Cylinder 4
<p>* High ridges of displaced metal can interfere with operation of new piston rings. The displaced metal can cause excessive piston ring clearance.</p>	

Piston Inspection Checklist (Cont.)

NOTICE: Lycoming manufactures pistons with a taper that extends from the top to the bottom of the skirt with the smaller diameter at the top.

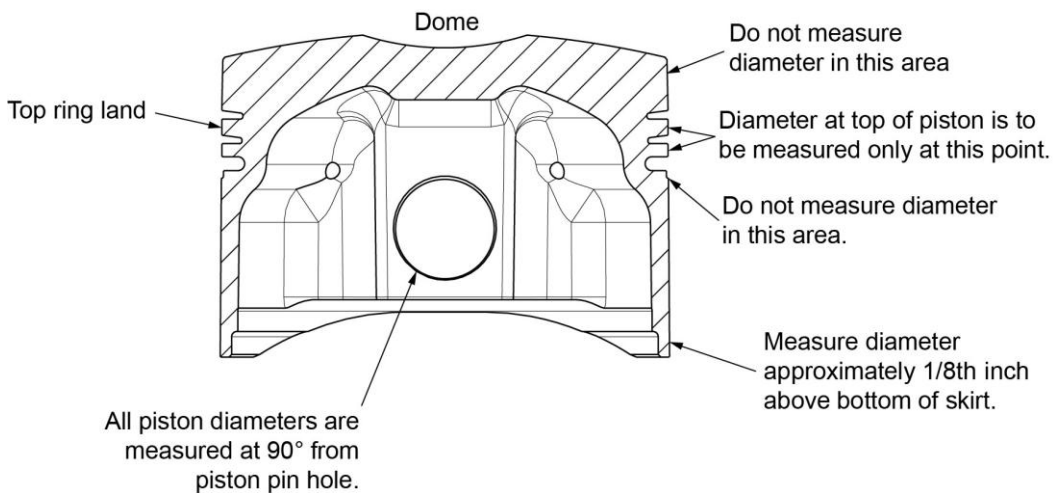
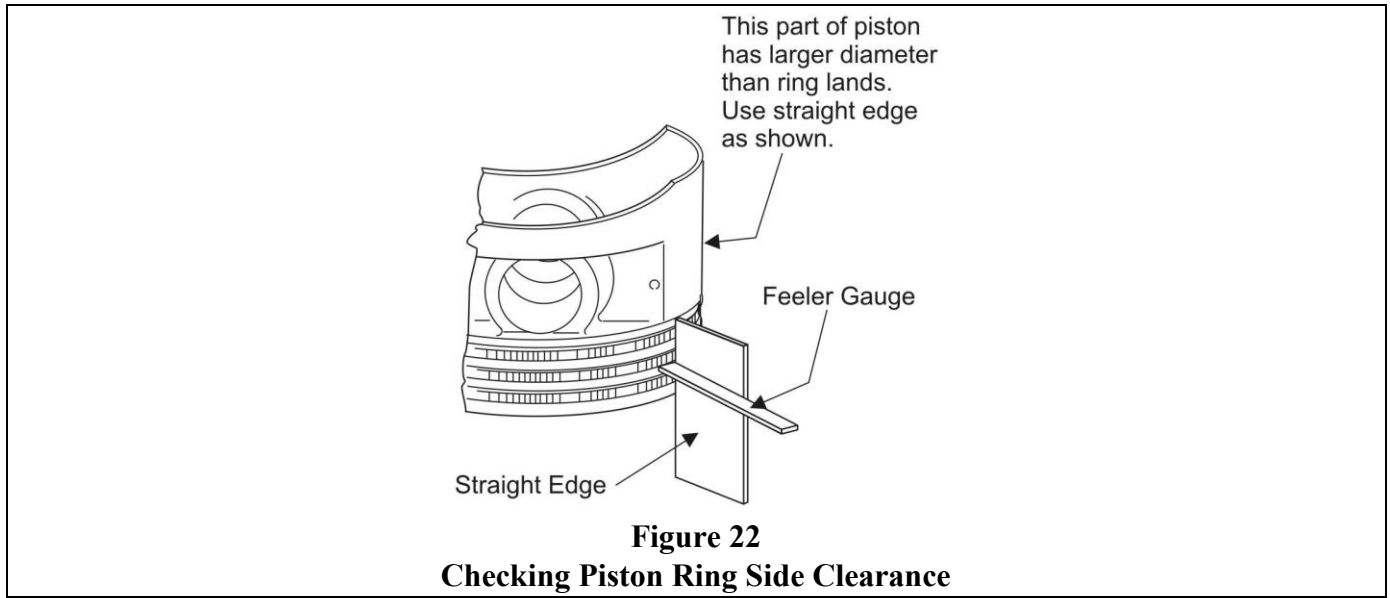


Figure 21
Section Through Piston Showing Points for Measuring Diameter

Inspection Item		Findings/Corrective Action			
		Cylinder 1	Cylinder 2	Cylinder 3	Cylinder 4
Measure the inside diameter of the piston pin hole (Figure 21).	Actual Measurement**				
	SSP-1776				
Measure the piston diameter at the top ring land of the piston between the top and second compression ring grooves (at a right angle to the piston pin hole) (Figure 21).	Actual Measurement**				
	SSP-1776				
Measure the diameter approximately 1/8 in. above the bottom of the piston skirt. (at a right angle to the piston pin hole) (Figure 21).	Actual Measurement**				
	SSP-1776				
Measure the piston ring clearance.	Actual Measurement**				
	SSP-1776				

**Compare the actual measurement against the limits in the latest revision of the *Service Table of Limits - SSP-1776*. Replace the piston if any of the measurements are out of tolerance.

Piston Inspection Checklist (Cont.)



Inspection Item			Findings/Corrective Action			
			Cylinder 1	Cylinder 2	Cylinder 3	Cylinder 4
Measure the side clearance between the piston rings and piston with a feeler gauge and straight edge (Figure 22).	Top compression piston ring	Actual Measurement**				
		SSP-1776				
	Second compression piston ring	Actual Measurement**				
		SSP-1776				
	Oil regulating piston expander ring	Actual Measurement**				
		SSP-1776				
Measure the piston ring end-gap with feeler gauges. Complete the "Piston Ring End-Gap Check" in this chapter.	Top compression piston ring	Actual Measurement**				
		SSP-1776				
	Second compression piston ring	Actual Measurement**				
		SSP-1776				
	Oil regulating piston expander ring	Actual Measurement**				
		SSP-1776				

**Compare the actual measurement against the limits in the latest revision of the *Service Table of Limits - SSP-1776*. Replace the piston if any of the measurements are out of tolerance.

Piston Inspection Checklist (Cont.)**Comments:**

If inspection of the piston shows the original ground surface of the piston skirt to be undamaged, the piston is acceptable and can be re-installed.

If any of the following conditions are found on the piston, replace the piston.

- Damage
- Cracked, bent, or broken lands, scored skirts or any out-of-tolerance dimensional limits
- Piston grooves worn to the extent that relatively high steps or ridges are on the lower lands

NOTICE: Refer to the applicable parts catalog to identify a replacement piston and associated rings.

B. Piston Ring End-Gap Check

⚠ CAUTION: DURING THE PISTON RING END-GAP CHECK, USE CARE NOT TO SCRATCH OR SCORE THE PISTON OR CYLINDER BORE.

- (1) Lubricate the piston ring, piston, and cylinder bore with a light coating of a mixture of 15% pre-lubricant (STP or equivalent) and 85% SAE 50 mineral-base aviation-grade lubricating oil
- (2) Put one of the piston rings in the cylinder in which it will be used.
- (3) To square the piston ring in the cylinder bore, install the piston in the cylinder and use a soft mallet to tap the dome end of the piston on the inside, until the bottom of the piston skirt is flush with the end of the cylinder barrel. Remove the piston from the cylinder.
- (4) Measure the piston ring end-gap with feeler gauges. Record the measurement in the Piston Inspection Checklist. Compare the measurement with the ring end-gap measurement in the latest revision of the *Service Table of Limits - SSP-1776*.
- (5) If necessary to increase the end-gap, carefully file the ends of the piston ring.
- (6) Repeat this check for each piston ring to be used in each cylinder.

11. Piston Ring Replacement

⚠ CAUTION: DO NOT ***UNDER ANY CIRCUMSTANCES*** INSTALL CHROME-PLATED PISTON RINGS IN AN ENGINE HAVING CHROME-PLATED CYLINDER BARRELS. IF YOU ARE UNSURE OF THE CORRECT COMBINATION OF PISTON RINGS TO BE USED, REFER TO THE LATEST REVISION OF SERVICE INSTRUCTION NO. SI-1037.

DURING REMOVAL OF THE THREE PISTON RINGS IN THE NEXT STEP, USE CARE NOT TO SCRATCH OR SCORE THE PISTON.

- A. Start from the top down, use the commercially available piston ring expander tool to remove the two top compression rings, the oil regulating piston expander ring, and the inner expander ring (Figure 23).

NOTICE: New cylinders made by Lycoming Engines will have the correct piston ring finish and do not need further honing. Otherwise, hone the cylinder per the latest revision of Service Instruction No. SI-1047 to ensure correct seating of the new piston rings. For new piston rings, refer to the applicable parts catalog to identify the correct new piston rings to be installed on the piston.

New piston rings are shipped from Lycoming Engines with the oil regulating piston expander ring and the inner expander ring assembled. The inner expander ring must be separated from the oil regulating piston expander ring before installing them on the piston.

- B. Apply a generous coating of a mixture of 15% pre-lubricant (STP or equivalent) and 85% SAE 50 mineral-base aviation-grade lubricating oil (unless otherwise directed per the latest revision of Service Instruction No. SI-1059) to the piston rings.
- C. With the piston top side up on a workbench, install the inner expander ring in the first groove above the piston hole (Figure 23).

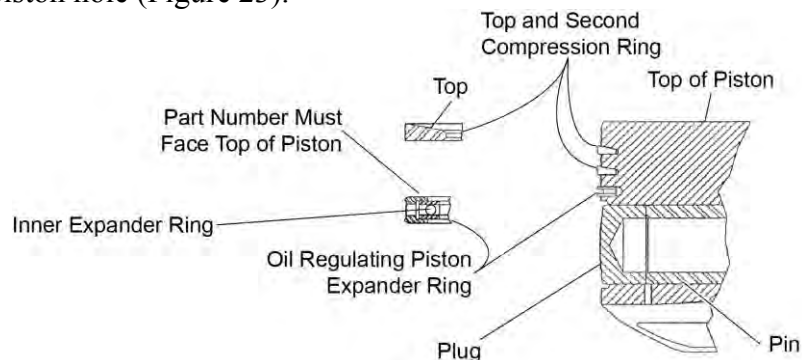


Figure 23
Piston Ring Positions

- D. Assemble the oil regulating expander ring over the expander with its gap 180° opposite the inner expander ring gap. Compress the assembly several times with the fingers to assure that the ring lies free and loose in the groove. Both the regulating rings and the expander are symmetrical, but the oil regulating expander ring is to be installed with the part number toward the top of the piston.
- E. Install the two top compression rings (Figure 23) with the word "Top" toward the top of the piston in the remaining top grooves.

- F. Compress each of the two top compression piston rings several times with your fingers to make sure the rings are situated freely and loosely in the groove.
- G. To ensure correct installation, measure the side clearance of the rings in the grooves with a feeler gage and a straight edge (Figure 22). If the actual measurement is greater than the maximum allowable side clearance, per the latest revision of the *Service Table of Limits - SSP-1776*, replace the piston.

NOTICE: A field run-in must be completed any time one or more cylinders are removed. Refer to the latest revision of Service Instruction No. SI-1427 and the “Field Run-In” chapter of the *IO-390-C Series Engine Installation and Operation Manual*.

12. Piston Installation

- A. Clean the pistons as per instructions in the “Piston Cleaning” procedure in Chapter 05-30.
- B. Apply lubricant specified in the latest revision of Service Instruction No. SI-1059 to the piston pin and the ID of the piston pin hole.

⚠ CAUTION: DO NOT ATTEMPT TO TURN THE CRANKSHAFT UNLESS THE CONNECTING RODS ARE SUPPORTED.

- C. Turn the crankshaft so that when the Number 1 piston is inserted, it will be at TDC of its firing stroke, with both tappets on the base circle of the camshaft lobes.
- D. Remove the Torque Hold-Down Plates (ST-222), rubber bands, or cylinder base oil seals from the crankcase.
- E. Install the piston on the connecting rod where the number stamped on the bottom of the piston head is upright and readable (not upside-down.)
- F. Insert the piston pin into the piston and through the connecting rod (Figure 18) to ensure the entire length of the piston pin is lubricated move the piston pin back and forth until it is centered.

NOTICE: If the original piston pin is tighter than a palm push fit, look for burrs or slight carbon in the pin bore of the piston. Remove any burrs with a stone. Remove carbon deposits as per instructions in Chapter 5-30. If a new piston or piston pin is installed, use a pin that will give a palm push fit at 60° to 70°F (15° to 20°C).

- G. Insert a piston pin plug at each end of the piston pin.
- H. Complete a check of the clearance between the piston and each piston pin plug. Refer to the latest revision of the *Service Table of Limits - SSP-1776* for acceptable clearance limits.
- I. Install the piston rings on the piston per the “Piston Ring Replacement” procedure.
- J. Apply a generous coating of a mixture of 15% pre-lubricant (STP or equivalent) and 85% SAE 50 mineral-base aviation-grade lubricating oil (unless otherwise directed per the latest revision of Service Instruction No. SI-1059) to the piston rings, working the mixture into the ring grooves.
- K. Apply lubricant specified in the latest revision of Service Instruction No. SI-1059 to the piston pin plug faces.

13. Intake Valve Replacement

A. Intake Valve Removal

- (1) Remove the cylinder from the engine per the “Cylinder Removal” procedure in this chapter.

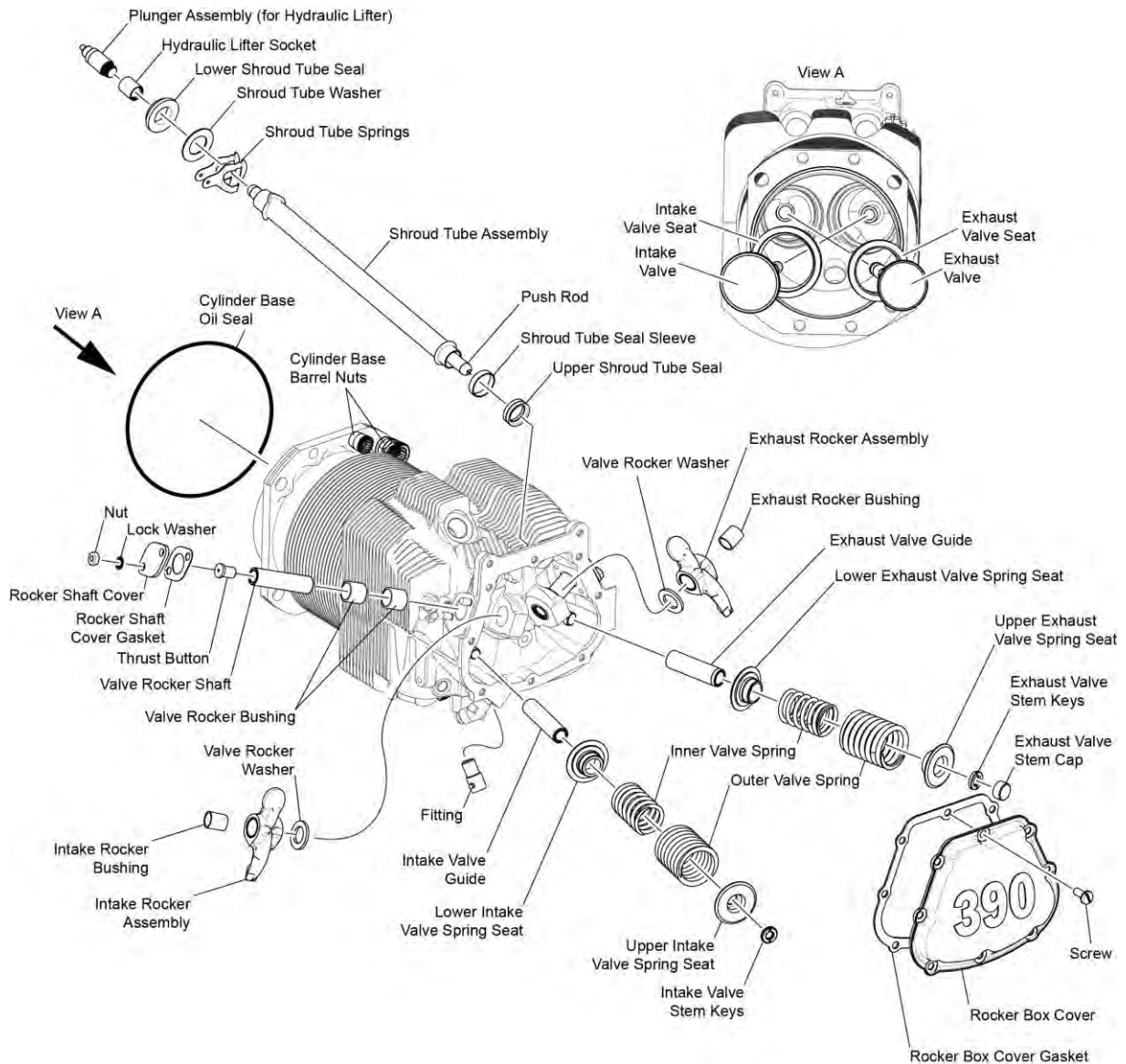


Figure 24
Intake and Exhaust Valves

- (2) Compress the intake valve springs with a Valve Spring Compressor Tool (ST-25) and remove the valve stem keys (Figure 24).

- (3) Remove the valve spring seats and valve springs from the intake valve.

NOTICE: Use care not to scratch the inside of the cylinder barrel when removing the intake valve.

- (4) Remove the intake valve from the valve guide, through the cylinder barrel.

B. Intake Valve Installation

NOTICE: Use care not to scratch the inside of the cylinder barrel when installing the intake valve (Figure 24).

- (1) Apply a coating of Castrol® Contractor Special NLGI#1 to the intake valve stem (or other lubricant identified in the latest revision of Service Instruction No. SI-1059.)
- (2) Install a serviceable intake valve in the valve guide (Figure 24), through the cylinder barrel.
- (3) Install the valve spring seats and valve springs.
- (4) Compress the intake valve springs with a Valve Spring Compressor Tool (ST-25) and install the valve stem keys.
- (5) Install the cylinder on the engine per the “Cylinder Installation” procedure in this chapter.

14. Exhaust Valve Replacement

A. Exhaust Valve Removal

- (1) Remove the cylinder from the engine per the “Cylinder Removal” procedure in this chapter.
- (2) Remove the exhaust valve stem cap (Figure 25).
- (3) Compress the exhaust valve springs with a Valve Spring Compressor Tool (ST-25) and remove the valve stem keys (Figure 24).
- (4) Remove the valve spring seats, and valve springs from the exhaust valve.



Figure 25
Exhaust Valve Stem Cap

NOTICE: Use care not to scratch the inside of the cylinder barrel when removing the exhaust valve.

- (5) Remove the exhaust valve from the valve guide, through the cylinder barrel.

B. Exhaust Valve Installation

NOTICE: Use care not to scratch the inside of the cylinder barrel when installing the exhaust valve.

- (1) Apply a coating of Castrol® Contractor Special NLGI#1 to the exhaust valve stem (or other lubricant identified in the latest revision of Service Instruction No. SI-1059.)
- (2) Install a serviceable exhaust valve in the valve guide, through the cylinder barrel.
- (3) Install the valve spring seats and valve springs,
- (4) Use a Valve Spring Compressor Tool (ST-25) to compress the exhaust valve springs and install the valve stem key.
- (5) Install the valve stem cap (Figure 25) on the exhaust valve.
- (6) Install the cylinder on the engine per the “Cylinder Installation” procedure in this chapter.

15. Cylinder Installation

NOTICE: Use a cylinder kit when installing a new cylinder.

If all cylinders are to be installed, install them by their firing order 1 - 3 - 2 - 4.

⚠ CAUTION: INSTALL THE CYLINDER BASE OIL SEAL RING (FIGURE 24) AROUND THE CYLINDER BASE. DO NOT USE ANY ADDITIONAL SEALANT OR GASKET MATERIAL WHICH COULD DETERIORATE WHICH COULD CAUSE A REDUCED TORQUE ON THE CYLINDER BASE STUDS.

NOTICE: Do not re-install the cylinder base oil seal ring which had been removed during cylinder removal (and re-used as a support for connecting rods). Use a new cylinder base oil seal ring.

- A. Install a new cylinder base oil ring around the cylinder base for each engine cylinder.
- B. Apply a light coat of engine oil mixture to the cylinder base oil seal ring.
- C. Lubricate the inside diameter of the cylinder barrel with engine oil mixture (15% pre-lubricant (STP or equivalent) and 85% SAE No. 50 mineral base aviation grade lubricating oil) to the depth of the piston rings, approximately 2 in. (5 cm).
- D. Apply one or a combination of any of the following lubricants to the outer three threads (Figure 26A) on all of the crankcase thru-studs and cylinder hold-down studs (Figure 26B):
 - Parker Thread Lube
 - Mixture of 60% SAE 30W engine oil and 40% Parker Thread Lube
 - SAE 30W engine oil
 - Mixture of 90% SAE 50W engine oil and 10% STP

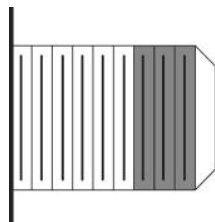


Figure 26A

Stud Thread Location for Lubricant

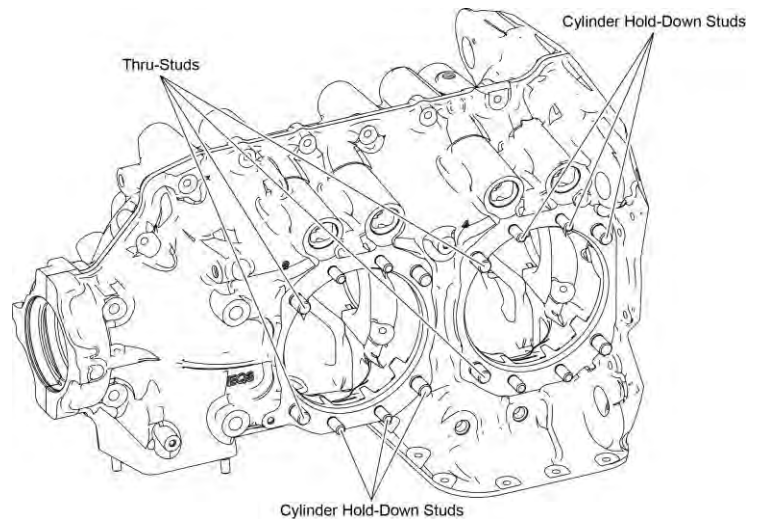


Figure 26B

**Crankcase Thru Studs and
Cylinder Hold-Down Studs**

- E. If not already done, install both rocker shafts in the cylinder head (Figure 24).
- F. Use the Piston Ring Compressor (ST-485) to install the cylinders (Figure 27) as follows:
 - (1) Assemble the piston ring compressor (ST-485) over the top piston rings and install the correct cylinder over the piston on the corresponding connecting rod, pushing the piston ring compressor ahead with the cylinder barrel (Figure 28).

- (2) As the cylinder barrel approaches the crankcase, catch the piston ring compressor as it drops off the piston skirt.
- (3) As the cylinder assembly pilot is entering the crankcase, align the cylinder hold-down studs with the holes in the cylinder flange.
- (4) Push the cylinder until the cylinder flange makes contact with the crankcase.
- (5) Install a vented plug in each spark plug hole to prevent the entrance of foreign materials.

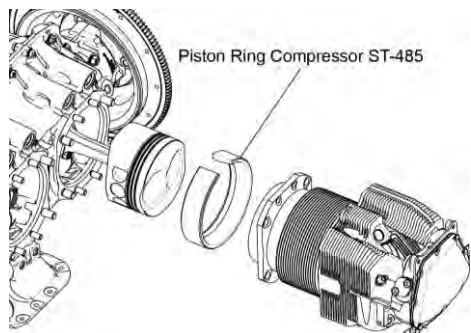


Figure 27
Piston Ring Compressor (ST-485)



Figure 28
Install the Cylinder

G. Install the cylinder base hold-down barrel nuts (Figure 17) on the thru-studs and cylinder hold-down studs.

⚠ CAUTION: TO ENSURE CORRECT CYLINDER INSTALLATION, TORQUE THE CYLINDER NUTS IN THE SPECIFIC SEQUENCE IN FIGURE 29.

H. Torque the cylinder base hold-down barrel nuts as follows:

- (1) Torque the 1/2 in. nuts to 300 in.-lb (25 ft.-lb) (33.9 Nm) in the sequence shown in Figure 29.
- (2) Torque the 1/2 in. nuts to 600 in.-lb (50 ft.-lb) (67.8 Nm) in the sequence shown in Figure 29.
- (3) Install the 3/8 in. nuts on the remaining cylinder base studs. Torque these nuts to 25 ft.-lb. (34 Nm). The torque sequence for these nuts is optional.

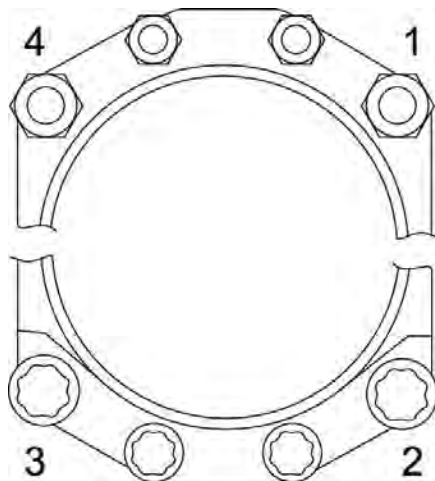


Figure 29
Sequence of Tightening Cylinder Base Hold-Down Barrel Nuts

- I. Use the same sequence shown in Figure 29, complete a torque check to 50 ft.-lb. (68 Nm) for all 1/2-in. nuts on the cylinder base studs.
- J. Tighten both ends of the free thru-studs at the same time at all locations. Make sure all thru-studs have at least 1-1/2 threads above attaching nuts at both ends.
- K. Make sure all cylinder base hold-down nuts are torqued. Complete a torque check of all nuts on the cylinder base using the torque wrench to apply the appropriate torque on each nut for 5 seconds. If the nut does not turn, it is correctly torqued.
- L. Apply torque seal to all cylinder hold-down nuts.

⚠ CAUTION: MAKE SURE ALL CYLINDER FASTENERS ON THE CRANKCASE ARE TORQUED CORRECTLY AND NONE ARE LOOSE.

M. Shroud Tube Installation

⚠ CAUTION: BE SURE THERE IS NO OIL INSIDE THE TAPPET BODIES AND THAT THE PLUNGER ASSEMBLY AND CYLINDER ASSEMBLY ARE THOROUGHLY CLEAN AND DRY. WASH ANY LUBRICATING OR PRESERVATIVE OIL (MINERAL SPIRITS, STODDARD SOLUTION, OR EQUIVALENT) FROM THESE PARTS, SINCE PLUNGER ASSEMBLIES MUST BE ABSOLUTELY DRY FOR THE TAPPET CLEARANCE CHECK.

NOTICE: Install the upper and lower shroud tube seals (Figure 24) in the crankcase first.

One shroud tube installs on the exhaust port of the cylinder and another shroud tube installs on the intake port.

The tappet plunger must be the one for the applicable tappet socket on the corresponding cylinder.

- (1) For each of the two shroud tubes, install the plunger assembly and hydraulic socket in the tappet body in the crankcase (Figure 30).
- (2) Apply engine oil mixture (15% pre-lubricant (STP or equivalent) and 85% SAE No. 50 mineral base aviation grade lubricating oil) to all four of the shroud tube seals, two for each shroud tube.
- (3) Install new upper and lower shroud tube seals into the cups in the tappet bores of the crankcase (Figure 31) and cylinder head.
- (4) On each shroud tube, assemble the other shroud tube seal and sleeve over the outer end of the shroud tube (Figure 15).

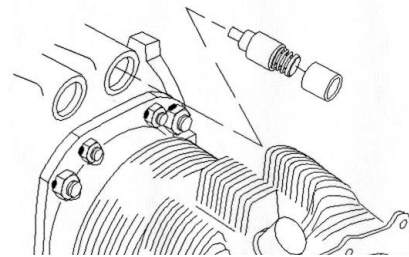


Figure 30
Tappet Plunger and Socket



Figure 31
Shroud Tube Oil Seals in Crankcase

- (5) Install the shroud tube spring and washer over the inner ends of each shroud tube where the detent notches in the spring are 90° removed from the tangs on the shroud tubes as shown in Figure 32.



Figure 32
Shroud Tube with Springs and Washer

- (6) Install each shroud tube through the shroud tube seal in the crankcase.
- (7) Hold both shroud tubes with the detent at the inner end at the unlocked position and insert the outer end of the tubes in the rocker box of the cylinder head.



Figure 33
Shroud Tube Wrench ST-142

- (8) Make sure that all shroud tube seals are installed squarely.
- (9) Turn each shroud tube 90° and use either a shroud tube wrench, ST-142 (Figure 33) or an internal pipe wrench to engage the tangs with the detents in the springs to lock each shroud tube in position.



Figure 34
Correctly Aligned Shroud Tube Springs

- (10) As necessary, gently tap the shroud tube springs with a rubber mallet to correctly and securely seat these springs (Figure 34).

N. Push Rod Installation

- (1) Make sure that the valves on the applicable cylinder are closed on the top dead center of the compression stroke.
- (2) Install the valve stem cap over the exhaust valve stem (Figure 24).
- (3) Install the push rods into the full length of the shroud tube.
- (4) Press the push rods tightly from the outer end of the shroud tube to test the spring tension and free travel of the unloaded or dry hydraulic tappet plungers. Make sure the springs compress and return.

⚠ CAUTION: EXHAUST AND INTAKE ROCKER ASSEMBLIES ARE DIFFERENT. MAKE SURE THAT THE ROCKERS ARE CORRECTLY ASSEMBLED AND INSTALLED ON THE CORRECT SIDE (INTAKE OR EXHAUST) OF THE CYLINDER.

- O. Install the rockers with the cupped end on the push rod.
- P. Align each valve rocker assembly (including the washer and bushing) with the rocker shaft.
- Q. Slide the rocker shafts through each valve rocker assembly (Figure 24) to seat the valve rocker in place for both the intake and exhaust valves.

- R. Make sure the valve rocker assemblies are in the correct position on the intake and exhaust valves.
- S. Install the valve rocker shaft cover with a new valve rocker shaft cover gasket, new lock washers and nuts. Torque the nuts to 96 in.-lb. (11 Nm).

⚠ CAUTION: BE SURE THERE IS NO OIL INSIDE THE TAPPET BODIES AND THAT THE TAPPET PLUNGER AND CYLINDER ASSEMBLY ARE THOROUGHLY CLEAN AND DRY. WASH ANY LUBRICATING OR PRESERVATIVE OIL (MINERAL SPIRITS, STODDARD SOLUTION, OR EQUIVALENT) FROM THESE PARTS, SINCE TAPPET ASSEMBLIES MUST BE ABSOLUTELY DRY FOR THE TAPPET CLEARANCE CHECK.

NOTICE: If the clearance between the valve rocker and the cylinder head cannot be brought within the *Service Table of Limits - SSP-1776* install the standard valve rocker thrust washer per the latest revision of Service Bulletin No. SB-225 for replacement valve rocker thrust washers.

- T. Measure the clearance between the valve rocker and cylinder head. Refer to the latest revision of the *Service Table of Limits - SSP-1776*.

NOTICE: The procedure to measure dry tappet clearance is the same for intake or exhaust valves.

- U. To measure the dry tappet clearance:

- (1) Push in on the push rod end of the valve rocker.
- (2) Use a Valve Clearance Gage (ST-23) (Figure 35) to measure the distance between the end of the valve rocker assembly and the valve stem cap (Figures 36 and 37).
 - (a) Insert the 0.028 end of the Valve Clearance Gage (ST-23) between the valve rocker assembly and the valve stem cap. If it cannot be inserted, use a shorter pushrod.
 - (b) Try to insert the 0.080 end of the Valve Clearance Gage (ST-23) between the valve rocker assembly and the valve stem cap. If it can be inserted, use a longer pushrod.
- (3) The distance must be between 0.028 and 0.080 in. (0.711 to 2.032 mm) (Figure 36).

NOTICE: If the clearance is not within the prescribed limit, insert a longer or shorter push rod to obtain the correct clearance. Refer to the latest revision of Service Instruction No. SI-1060 or the applicable parts catalog for available push rods.



Figure 35
Valve Clearance Gage
(ST-23)

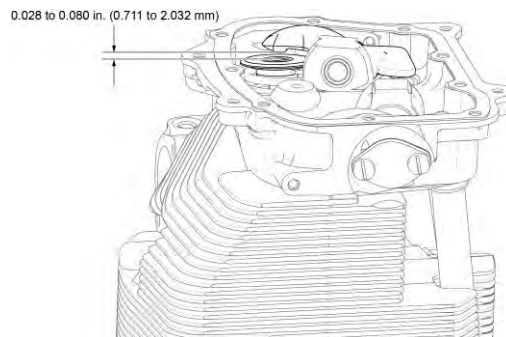


Figure 36
Dry Tappet Clearance

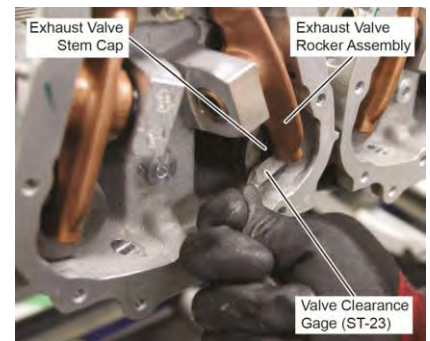


Figure 37
Measuring Dry Tappet
Clearance

- V. Recheck the valve rocker clearance on all cylinders and make any adjustments as required.
- W. Lubricate rocker contact surfaces with Modoc® Oil 175.
- X. Install the screws, rocker box cover with a new gasket on the cylinder head (Figure 24). Torque the screws per the Special Torque Requirements Table in the latest revision of the ***Service Table of Limits - SSP-1776***.
- Y. Remove the vented plug from each spark plug hole.
- Z. Install the top and bottom spark plugs as per the section “Spark Plug Installation” in Chapter 74-20.
- AA. Remove the caps from the fuel line and fuel injection nozzle and reconnect the fuel line to the injection nozzle. Refer to the latest revision of the ***Service Table of Limits - SSP-1776*** for torque values.
- AB. Install the clamps that attach the fuel line to the shroud tube per instructions in the latest revision of Service Bulletin No. SB-342.
- AC. Install the applicable intake pipe on the cylinder per the “Intake Pipe Installation” procedure in Chapter 72-80. Install the applicable exhaust pipe on the cylinder per the airframe manufacturer’s instructions.
- AD. Intercylinder Baffle Installation
 - (1) Engage the "S-Type" retaining hook (Figure 3) through the hole in the baffle.
 - (2) Put the baffle in position beneath and between the cylinders and turn the hook up between the cylinder barrels.
 - (3) Put a baffle retainer in place between the cylinders and bring the retainer hook through the slot in the retainer. The retainer is forced down until the hook is above the surface of the retainer far enough to be engaged over the bridge between the slots in the retainer.
- AE. Oil Drain Tube Installation
 - (1) Connect a new hose to the nipple (Figure 38) in the crankcase.
 - (2) Install and tighten a hose clamp on the hose closest to the crankcase.
 - (3) Connect the oil drain tube to the elbow at the cylinder with a flange nut. Torque the nut per the latest revision of the ***Service Table of Limits - SSP-1776***.
 - (4) Connect the new hose to the drain tube assembly.
 - (5) Install and tighten a hose clamp on the hose and oil drain tube connection.
 - (6) Torque both hose clamps per the Special Torque Requirements Tables in Part 1, Section V in the latest revision of the ***Service Table of Limits - SSP-1776***.
- AF. Connect the correct ignition lead to each spark plug per the section “Ignition Harness Installation” in Chapter 74-20.
- AG. Complete the “Oil Change Procedure” in Chapter 12-10.

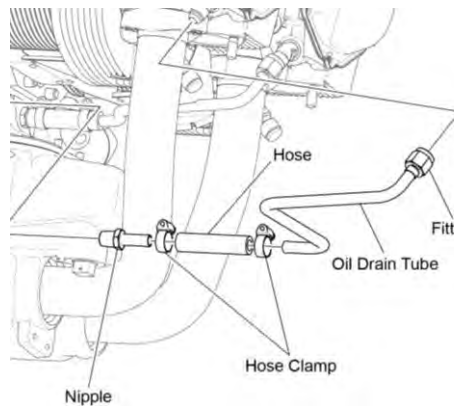


Figure 38
Oil Drain Tube

16. Corrective Action for Valve Sticking

NOTICE: If valve sticking is a problem, complete the 1000-hour inspection (regardless of the number of engine operating hours). After correcting the cause of valve sticking, complete the 1000-hour inspection after the next 1000 hours of engine operation, unless valve sticking occurs again.

Sticking between the valve stem and guide (on intake and exhaust valves) can substantially change valve opening and closing. If the valve cannot open or close correctly, incomplete combustion will occur, which can cause formation of more deposits and increased valve sticking. Because a correctly-timed sequence of valve opening and closing is essential to efficient and reliable engine operation, the cause of valve sticking must be identified and corrected.

⚠ WARNING: A STUCK VALVE CAN CAUSE ENGINE FAILURE.

NOTICE: If one valve is sticking, examine all other valves on all of the engine cylinders as a precaution.

- A. Per Chapter 12-10, complete an oil and filter change (or oil pressure screen cleaning) and have an analysis done on the oil and material in the oil filter or oil pressure screen to identify the contamination and find the source to correct the problem.
- B. If the source of the oil contamination cannot be found or corrected:
 - (1) Replace the oil filter (more often) every 25 hours of operation or clean the oil pressure screen every 25 hours of operation.
 - (2) Complete an oil change every 25 hours of operation.
- C. Complete an air filter change and apply a cover over the induction system to keep dirt out of the oil supply.
- D. Examine the cooling air baffles and baffle strips for contamination. Remove any contamination.
- E. Identify with a tag and remove the top spark plugs from the engine cylinders per the “Spark Plug Removal” procedure in Chapter 74-20.
- F. Identify the location of each cylinder and valve train component for reference on assembly and remove the cylinder and valve train components per the “Cylinder Removal” section in this chapter.
- G. Remove the intake and exhaust valves per the “Intake Valve Removal” and “Exhaust Valve Removal” sections in this chapter.
- H. Examine the valve stem keys/caps (Figure 24) for wear. Look for any distinct, uniform patterns. Replace worn valve stem keys or caps.

NOTICE: Refer to the latest revision of the *Service Table of Limits - SSP-1776* for valve guide dimensions to use the correct reamer.

Use reamer tools to remove hardened carbon from the valve guides.

- I. Apply ordinary cup grease on the flutes of the reamer to remove the deposits on the reamer.

J. Ream the valve guide as follows:

- (1) Apply force on the reamer to ensure the reamer has gone through the full length of the valve guide. The 1 in. (2.54 cm) pilot must be visible through the exhaust port or through spark plug hole using an angled mirror.
- (2) Clean the valve guide per the “Hard Carbon Removal” procedure in Chapter 05-30 for additional cleaning details.
- (3) Measure the inner diameter of the valve guide using the correct plug gage.
- (4) Examine the reamed hole to see if the reamer has cut all the way to the exhaust port end of the guide. If it has not, and the exhaust port end of the hole looks dark, the valve guide is bell-mouthed and must be replaced.
- (5) If the valve guide is acceptable, apply lubricant to the valve guide.

⚠ CAUTION: NEVER USE THE PISTON TO PUSH THE VALVE THROUGH THE GUIDE.

K. Install the valves that are satisfactory, in the same position where they were. Refer to the “Intake Valve Installation” and “Exhaust Valve Installation” procedures in this chapter.

L. Install the valve springs and valve spring seats.

M. Remove and clean the hydraulic lifter and remove all oil. Refer to the “Tappet Cleaning” procedure in Chapter 05-30.

N. Examine the lifter for any malfunction.

O. Clean the inner diameter of the cam follower.

P. Install the hydraulic lifter.

Q. Install the cylinder and valve train components in the same position as removed. Refer to the “Cylinder Installation” procedure in this chapter.

R. Install the spark plugs. Refer to Chapter 74-20 for spark plug inspection and installation instructions.

17. Intake and Exhaust Valve Guide Replacement

Any time a valve guide is to be replaced, send the engine cylinder to an authorized vendor who can complete this replacement.

18. Intake and Exhaust Valve Seat

If an intake or exhaust valve (Figure 39) is damaged or must be replaced, send the engine cylinder to an authorized vendor who can complete this replacement.

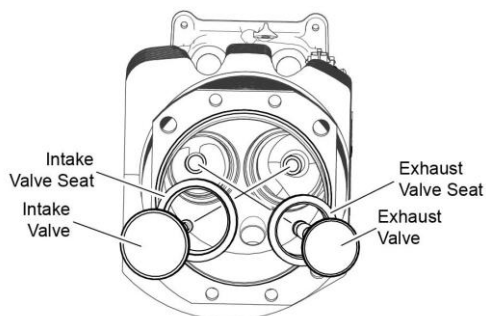


Figure 39
Intake and Exhaust Valve Seats

19. Barrel Glaze and Varnish Removal from Interior Cylinder Barrel

- A. Use a self-centering, self-bottoming hone that follows a choke located in the top of the cylinder barrel.
- B. Use kerosene or light engine oil for lubrication while honing.
- C. Put the deglazing hone in a low-speed drill.
- D. Surface hone each cylinder barrel with a minimum of six to eight passes over the glazed surface, using a smooth up and down motion of the hone to achieve a good cross-hatch pattern on the cylinder barrel wall.
- E. Thoroughly clean the hone.
- F. Wipe as much of the abrasive build-up from the cylinder walls and recesses as possible, especially the recesses formed by the top of the cylinder barrel and the bottom of the cylinder head.
- G. Make a hooked tool from soft wire and rub the tool back and forth in the recess to loosen any built-up abrasive. Complete this task each time the cylinder is flushed. There must not be any abrasive material in this area.
- H. Complete the “Cylinder Cleaning” procedure in Chapter 05-30.
- I. Lubricate the internal cylinder barrel thoroughly with SAE 50 engine oil or a rust preventative oil that conforms with MIL-C-6529.

NOTICE: If step wear is found inside the cylinder barrel, measure it using the dial bore gage usually used to measure cylinder diameter. If the depth of the step wear is less than 0.0025 in. (0.0635 mm), remove the step as per the previous steps to remove cylinder barrel glaze. If the barrel contains a wear step exceeding 0.0025 in. (0.0635 mm), replace the cylinder.

In some cylinders, a small rough area can be found at either end of the barrel extending less than 0.250 in. (6.35 mm) from the end. This condition is a result of the manufacturing process and has no effect on the quality or condition of the barrel.

20. Heli-Coil® Replacement

NOTICE: The IO-390-C Series engines have long reach spark plugs.

- A. Replace the spark plug Heli-Coil® insert (Figure 40) in the cylinder head if the threads in the spark plug hole in the cylinder are damaged (usually occurs when hard carbon on the end of the spark plug causes the insert to unwind during spark plug removal).

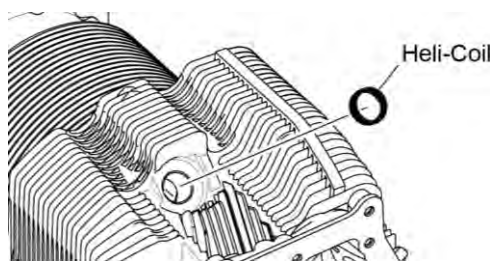


Figure 40
Heli-Coil®

NOTICE: Always install a larger oversized 0.010 in. (0.254 mm) Heli-Coil® insert in the spark plug hole on the cylinder head to replace a standard sized Heli-Coil® insert. Never replace a standard sized Heli-Coil® insert with another standard sized Heli-Coil® insert. The oversize Heli-Coil® inserts are identified by three marks on the tang of the Heli-Coil® insert as shown Figure 41.

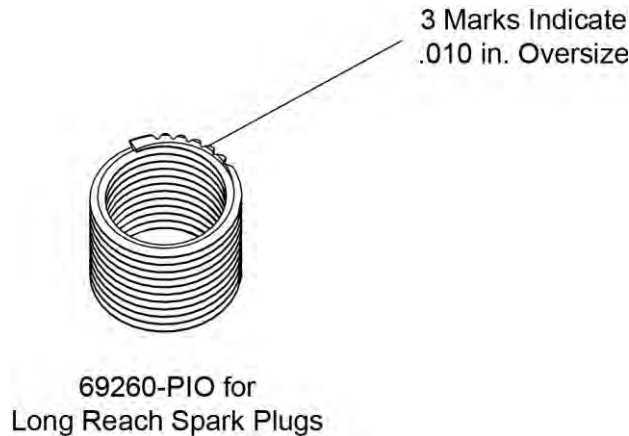


Figure 41
Heli-Coil® Inserts for Long Reach Spark Plugs

- (1) Disable all power to the engine to prevent propeller rotation and engine start. Disconnect ignition leads from all spark plugs.
- (2) If not already done, remove and discard the Heli-Coil® insert from the spark plug hole.
- (3) Apply a coat of grease liberally to the oversize tap.
- (4) If the Heli-Coil® insert is replaced while the cylinder is installed on the engine, take precautions to prevent metal shavings from falling into the combustion chamber.

⚠ CAUTION: IF METAL SHAVINGS FALL INTO THE COMBUSTION CHAMBER OF THE CYLINDER, STOP AND REMOVE ALL SHAVINGS AND DEBRIS. THE COMBUSTION CHAMBER MUST BE CLEAN.

- (5) Turn the crankshaft to the start of the compression stroke.
- (6) Put 8 ft. (2.4 m) of 3/8 in. (9.5 mm) nylon rope through the opposite spark plug hole.
- (7) Turn the crankshaft to force the rope against the bottom of the spark plug hole that is to be tapped.
- (8) Use the 0.010 in. oversize tap, to drill a larger oversize hole for the oversize insert.
- (9) Install the new oversize 0.010 in. Heli-Coil® insert in the spark plug hole. Refer to Figure 41.
- (10) Remove all chips and shavings to prevent contamination from foreign object debris.
- (11) Remove the rope from the spark plug hole.
- (12) Record replacement, in the engine logbook, of the standard sized Heli-Coil® insert with a new oversized Heli-Coil® insert for the applicable cylinder number.

72-50 - LUBRICATION SYSTEM MAINTENANCE

1. Oil Pressure Adjustment

NOTICE: On the majority of these engines, there is an adjustment screw (Figure 1) on the oil pressure relief valve housing. Rotation of this screw either increases or decreases the oil pressure to keep it within the specified operational limits in Appendix A of the *IO-390-C Series Engine Installation and Operation Manual*.

- (1) The engine must be installed in the aircraft or on a test stand to complete this procedure.
- (2) Start and operate the engine per instructions in the *IO-390-C Series Engine Installation and Operation Manual*.
- (3) Run-up the engine to 2000 rpm.
- (4) Record the oil pressure reading.
- (5) If the oil pressure is out of tolerance, turn off the engine and adjust the oil pressure as follows:
 - To *increase* oil pressure, turn the pressure adjustment screw on the oil pressure relief valve *clockwise* (Figure 1).
 - To *decrease* oil pressure, turn the adjustment screw on the oil pressure relief valve *counterclockwise*.
- (6) Start the engine and repeat the previous steps until the oil pressure is within specified limits.

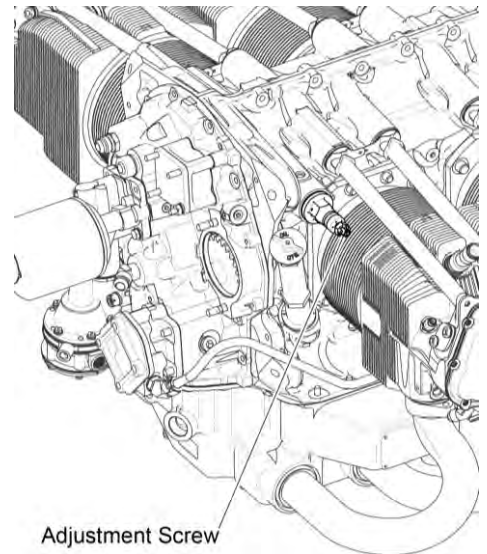


Figure 1
Adjustment Screw on the Oil Pressure Relief Valve

2. Oil System Inspection

- A. Look for leaks around the oil sump and crankcase flanges.
- B. If there are indications of leaking around the oil seals and gaskets, identify the source of the leak and take corrective action as necessary.
- C. Replace leaky oil seals and gaskets.

3. Oil Line Inspection

⚠ CAUTION: MAKE SURE THERE ARE NO SHARP BENDS OR KINKS IN THE OIL LINE ROUTING TO PREVENT INTERRUPTIONS TO OIL FLOW. MAKE SURE OIL LINES ARE NOT TOUCHING HEAT SOURCES THAT COULD DAMAGE THE OIL LINE AND CAUSE OIL LOSS.

- A. Examine oil lines for cracks, kinks, brittleness, wear, damage or loose connections. Replace any worn, cracked, kinked, damaged, or brittle oil line with a new oil line. Do not try to repair the oil line.
- B. Tighten any loose connection at an oil line per the torque values in the Standard Torque Tables in the latest revision of the *Service Table of Limits - SSP-1776*.

4. Oil Line Replacement

- A. Disconnect, drain, and discard the oil line.

⚠ CAUTION: REPLACE A BRITTLE, CRACKED, KINKED, OR DAMAGED OIL LINE.

- B. Install a new oil line; do not let the oil line touch a heat source.

⚠ CAUTION: MAKE SURE THERE ARE NO SHARP BENDS OR KINKS IN THE OIL LINE ROUTING TO PREVENT INTERRUPTIONS TO OIL FLOW. MAKE SURE OIL LINES ARE NOT TOUCHING HEAT SOURCES THAT COULD DAMAGE THE LINE AND CAUSE OIL LOSS.

- C. Torque the fitting connections on the oil line ends in accordance with the torque values in the Standard Torque Tables in the latest revision of the *Service Table of Limits - SSP-1776* and aircraft manufacturer’s instructions.

5. Oil Level Gage Tube and Assembly Removal

- A. Remove and discard the safety wire/cable (Figure 2) from the oil level gage tube.
- B. Carefully turn the oil level gage tube (Figure 3) to remove the oil level gage assembly and tube as a unit (with the dipstick and O-ring) from the engine. Discard the oil level gage gasket and oil level gage plug ring.
- C. Put the oil level gage assembly on a clean surface in a safe place to prevent damage to the components.



Figure 2
Safety Wire on the Oil Level Gage

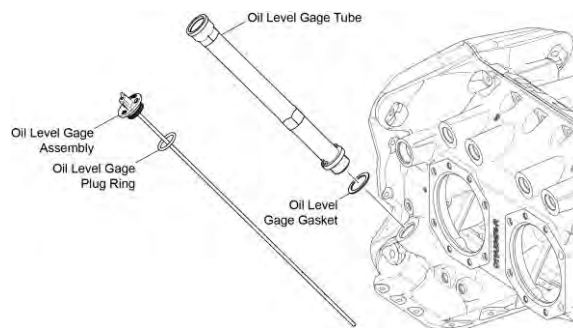


Figure 3
Oil Level Gage

6. Oil Level Gage Tube and Assembly Installation

NOTICE: Refer to the applicable parts catalog for the correct oil level gage assembly and oil level gage tube for your IO-390-C engine model.

- A. Install a new oil level gage gasket on the threads of the top of the oil level gage tube (Figure 3).
- B. Apply Food-Grade Anti-Seize to the threads of the oil level gage tube and oil level gage plug ring.
- C. Install the oil level gage tube on the engine.
- D. Safety wire/cable the oil level gage tube as shown in Figure 2. Refer to the latest revision of Service Instruction No. SI-1566.
- E. Install a new oil level gauge plug ring on the threads of the oil level gage assembly (Figure 3).
- F. Apply Food-Grade Anti-Seize to the threads at the top and bottom of the oil level gage tube.
- G. Install the oil level gage assembly (with the dipstick and new plug ring) in the oil level gage tube securely.

7. Oil Pressure Relief Valve Removal

- A. Remove and discard the safety wire from the oil pressure relief valve (Figure 4).
- B. Remove the oil pressure relief valve, spring, ball, and gasket (Figure 5) from the crankcase. Discard the gasket.



Figure 4
Safety Wire on the Oil Pressure Relief Valve

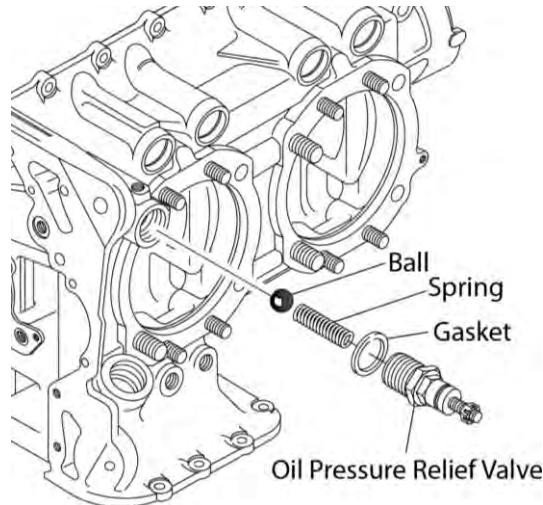


Figure 5
Oil Pressure Relief Valve

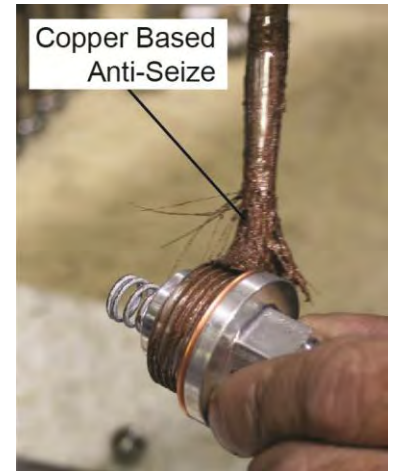


Figure 6
Apply Copper Based Anti-Seize to Threads

8. Oil Pressure Relief Valve Inspection

- A. Examine the oil pressure relief valve spring to be sure it meets specifications in accordance with the Special Torque Requirements Tables in Part 1, Section V in the latest revision of the **Service Table of Limits - SSP-1776**. The spring must allow a minimum of three threads exposed on the adjusting screw to allow field adjustment.
- B. Examine the threads on the oil pressure relief valve. If the threads are stripped or galled, replace the valve.

9. Oil Pressure Relief Valve Installation

- A. Install a new gasket on the oil pressure relief valve (Figure 5).

NOTICE: If the oil pressure cannot be adjusted to within specified limits by turning the adjustment screw, replace the spring with a spring that has a different compression load rating. Refer to the Special Torque Requirements Tables in Section V in the latest revision of **Service Table of Limits - SSP-1776** to select the correct spring.

- B. Install the correct spring in the oil pressure relief valve (Figure 5).
- C. Apply Copper-Based Anti-Seize to the threads of the oil pressure relief valve as shown in Figure 6.
- D. Install the ball in the crankcase.
- E. Install the oil pressure relief valve (with the correct spring) in the crankcase and torque to 300 in.-lb. (34 Nm).
- F. Safety wire/cable the oil pressure relief valve as shown in Figure 4. Refer to the latest revision of Service Instruction No. SI-1566.

10. Thermostatic Oil Cooler Bypass Valve Removal

- A. Remove and discard the safety wire/cable from the thermostatic oil cooler bypass valve (Figure 7).



Figure 7

Safety Wire on the Thermostatic Oil Cooler Bypass Valve:

On engines with an oil pressure screen (Figure 8). Remove the thermostatic oil cooler bypass valve and gasket from the oil pressure screen housing. Discard the gasket.

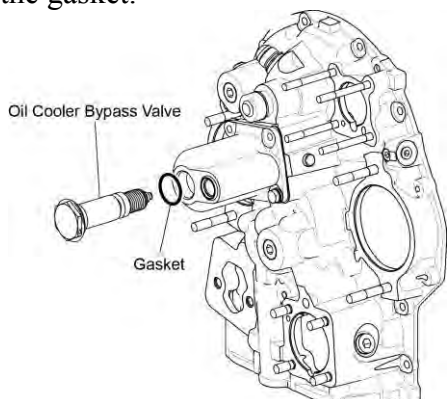


Figure 8

Thermostatic Oil Cooler Bypass Valve (Engine with Oil Pressure Screen)

On engines with an oil filter (Figure 9). Remove the thermostatic oil cooler bypass valve from the oil filter base. Discard the gasket.

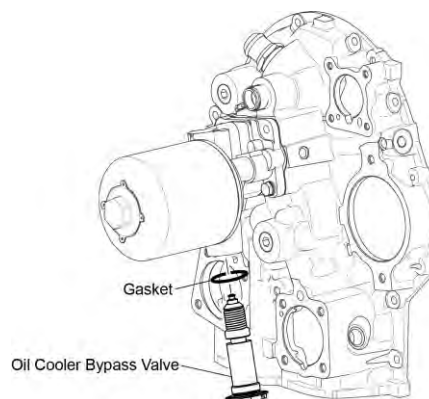


Figure 9

Thermostatic Oil Cooler Bypass Valve (Engine with Oil Filter)

11. Thermostatic Oil Cooler Bypass Valve Cleaning

Clean the thermostatic oil cooler bypass valve per instructions in the table in Chapter 05-30.

12. Thermostatic Oil Cooler Bypass Valve Installation

On engines with an oil pressure screen (Figure 8):

- A. Apply Food Grade Anti-Seize on the threads of the thermostatic oil cooler bypass valve.
- B. Install the thermostatic oil cooler bypass valve with a new gasket on the oil pressure screen housing (Figure 8).
- C. Torque the thermostatic oil cooler bypass valve to 300 in.-lbs. (34 Nm).
- D. Safety wire/cable the thermostatic oil cooler bypass valve.

On engines with an oil filter (Figure 9):

- A. Apply Food Grade Anti-Seize on the threads of the thermostatic oil cooler bypass valve
- B. Install the thermostatic oil cooler bypass valve with a new gasket on the oil filter base as shown in Figure 9.
- C. Torque the thermostatic oil cooler bypass valve to 300 in.-lbs. (34 Nm).
- D. Safety wire/cable the thermostatic oil cooler bypass valve.

13. Oil Pressure Screen Housing Removal

- A. Remove the four bolts, lock washers, and washers from the oil pressure screen housing (Figure 10). Discard the lock washers.
- B. Remove the oil pressure screen housing and gasket. Discard the gasket.
- C. Remove the oil pressure screen from its housing.

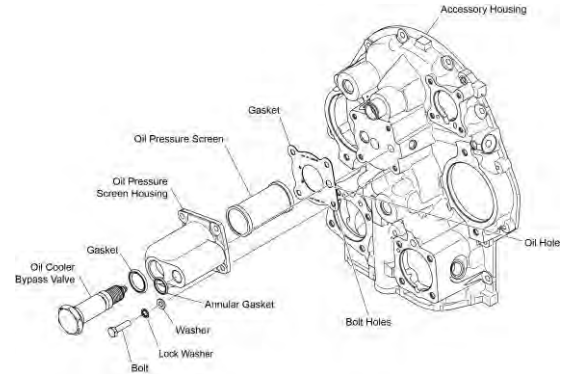


Figure 10
Oil Pressure Screen Housing

14. Oil Pressure Screen Housing Installation

- A. Install the oil pressure screen (Figure 10) in the oil pressure screen housing flush with the base of the oil pressure screen housing.
- B. Examine the new gasket for rips, damage, deformities, cracks or brittleness. Replace any cracked, brittle, deformed, torn or damaged gasket with a new gasket.

NOTICE: Make sure the new gasket for the oil pressure screen housing (Figure 10) aligns with the pad on the accessory housing and the oil pressure screen housing.

- C. Align the gasket with the bolt holes and oil holes on the oil pressure screen housing.
- D. Mount the oil pressure screen housing assembly with the new gasket on the pad of the accessory housing aligned with the bolt holes and oil hole on the pad of the accessory housing using the four bolts, each with a washer and a new lock washer as shown in Figure 10.
- E. Torque the four bolts 96 in.-lb (11 Nm).

15. Oil Filter Base Removal

- A. Refer to the “Oil Filter Replacement” procedure in Chapter 12-10 for oil filter removal instructions.
- B. Remove the hardware fasteners (nut, bolts, washers, and lock washers) from the oil filter base (Figure 11). Discard the lock washers.
- C. Remove the oil filter base (Figure 11).
- D. Remove and discard the gasket.

16. Oil Filter Base Installation

⚠ CAUTION: THE LETTERS ON THE GASKET MUST FACE THE OIL FILTER BASE TO PREVENT OIL LEAKAGE AND OIL STARVATION.

- A. Mount the oil filter base with a new gasket on the mounting pad where shown in Figure 11 with three bolts, flat washers, and new lock washers.

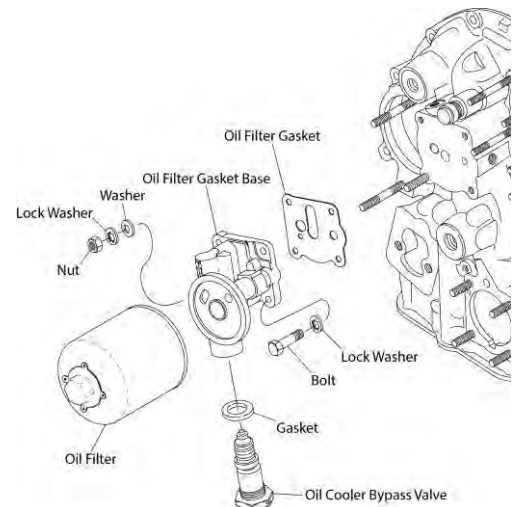


Figure 11
Oil Filter Base

- B. Install the nut, new lock washer, and washer on the stud.
- C. Initially torque the nuts in the sequence shown in Figure 12 to 25 in.-lb. (2.8 Nm).
- D. Complete the final torque of the nuts to 96 in.-lb. (10.9 Nm), in the sequence shown in Figure 12.

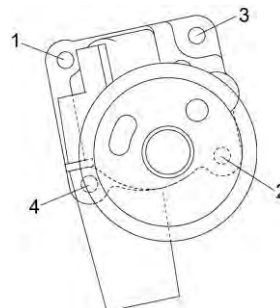


Figure 12
Torque Sequence for Oil Filter Base Fasteners

17. Oil Sump Removal

- A. Drain oil from the oil sump per the “Oil Change Procedure” in Chapter 12-10.
- B. If not already done, remove the intake pipes per Chapter 72-80.

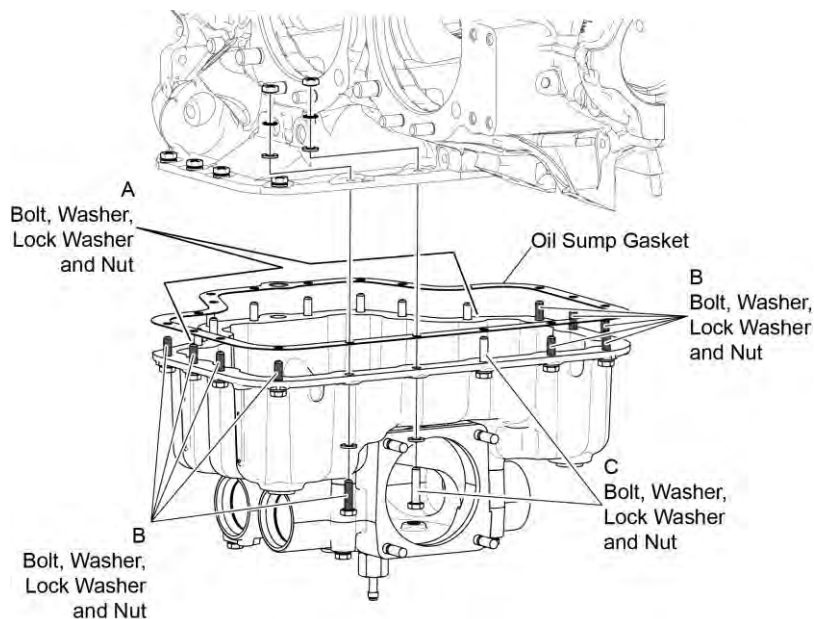


Figure 13
Oil Sump

NOTICE: In the next step, keep the A Bolts, B Bolts, and C Bolts separated.

- C. Remove and keep the eight “A” bolts, lock washers, and washers (Figure 13) that attach the oil sump to the accessory housing and crankcase. Discard the lock washers.
- D. Remove and keep the 10 “B” bolts, lock washers, flat washers, and nuts from the oil sump. Discard the lock washers.
- E. While one person holds the oil sump, remove and keep the two “C” bolts, lock washers, flat washers, and nuts from the locations shown in Figure 13 on the oil sump. Discard the lock washers.
- F. Remove the oil sump from the engine.
- G. Remove and discard the oil sump gasket.
- H. Turn over or cover the oil sump to prevent dirt and debris from getting in the oil sump.

18. Oil Sump Installation

- A. Clean the mating flange and interior of the oil sump with mineral spirits.
- B. Remove all gasket material on the flange. Make sure the oil sump has no cracks or damage, is clean and has no dirt, debris, or other foreign object matter that could contaminate the oil supply for the engine.
- C. Remove (cut away) any excess accessory housing gasket material that extends to the oil sump mounting surface. Excess gasket material must not extend between the accessory housing and crankcase. The gasket must be flush with the oil sump flange (Figure 14).

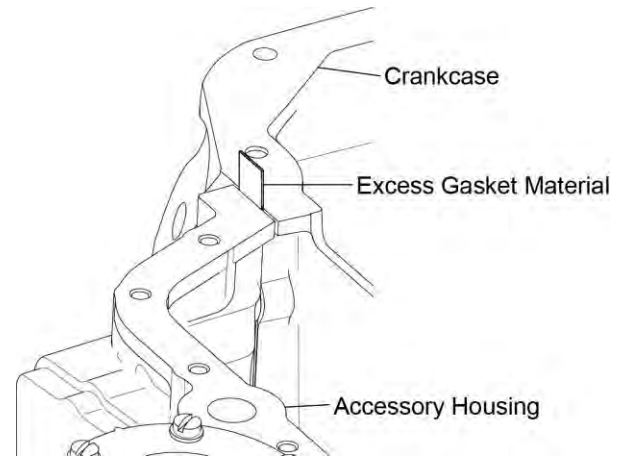


Figure 14
Remove Excess Accessory Housing Gasket to Make It Flush with the Oil Sump Flange

⚠ CAUTION: MAKE SURE THE OIL SUMP IS NOT CRACKED OR DAMAGED. THE OIL SUMP MUST BE CLEAN, WITHOUT DIRT, DEBRIS, OR OTHER FOREIGN OBJECT MATTER THAT COULD CONTAMINATE THE OIL SUPPLY. CONTAMINATED OIL CAN ADVERSELY AFFECT ENGINE OPERATION.

- D. Apply a dab of Gasket Sealant #4 (or equivalent) to four places in the split line between the accessory housing and crankcase where they mate with the oil sump (Figure 15).
- E. Install a new oil sump gasket in either the oil sump groove (Figures 13 and 16) or on the mating flange of the crankcase.

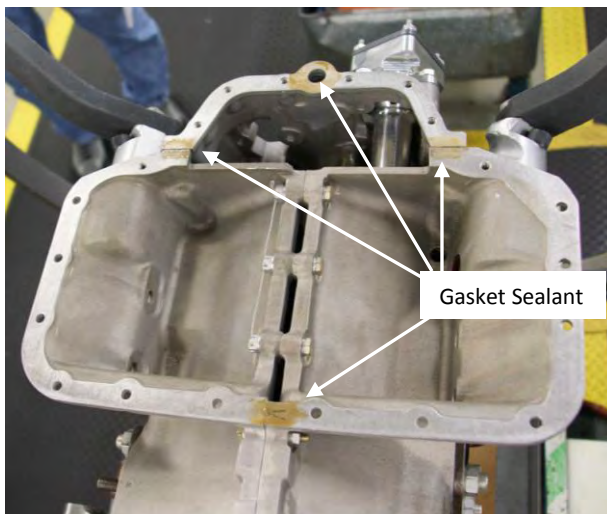


Figure 15
Gasket Sealant# 4 (or Equivalent) to Three Places on Oil Sump

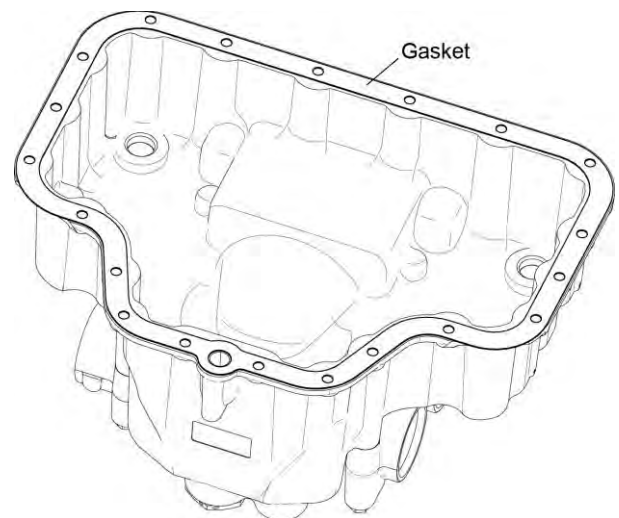


Figure 16
Oil Sump Gasket

- F. Align the oil sump flange with the bottom of the mated crankcase halves as shown in Figure 17.

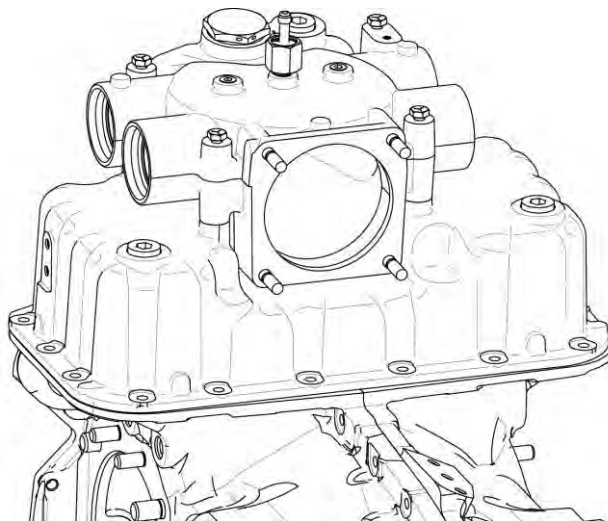


Figure 17
Oil Sump Aligned with Crankcase

⚠ CAUTION: ALL OF THE OIL SUMP FASTENERS (STUDS, BOLTS, AND NUTS) MUST BE INTACT TO ENSURE CORRECT AND SECURE TIGHTENING TO PREVENT OIL LEAKAGE AT THE OIL SUMP MATING FLANGE WITH THE CRANKCASE. NO OIL IS TO LEAK OUT OF THE OIL SUMP.

- G. Examine all of the oil sump fasteners identified as A, B, and C in Figure 13, that were to be kept separate when the oil sump was removed. Make sure the bolts, studs, and nuts are not damaged are intact and have no stripped threads. Replace any damaged or stripped fastener.
- H. Install the two “C” bolts each with a nut, two washers, and a new lock washer, at the location shown in Figure 13, finger-tight.
- I. Install the 10 “B” bolts, each with a nut, two washers and new lock washer finger-tight.
- J. Install the eight “A” bolts each with a washer and new lock washer finger-tight.
- K. Torque all of the bolts on the oil sump to 96 in.-lb. (11 Nm).

⚠ CAUTION: TO PREVENT OIL LEAKAGE, MAKE SURE THAT THE OIL DRAIN PLUG IS INSTALLED TIGHTLY IN THE OIL SUMP. SAFETY THE OIL DRAIN PLUG.

- L. Install the oil drain plug in the threaded hole of the oil sump. Torque the oil drain plug per the torque value in the latest revision of the *Service Table of Limits - SSP-1776*.
- M. Safety wire/cable the oil drain plug in accordance with the best standard practices per the latest revision of AC43.13-B or the latest revision of Service Instruction No. SI-1566.
- N. Install the intake pipes per Chapter 72-80
- O. After maintenance is completed, add the correct oil to the engine per instructions in Chapter 12-10.

19. Propeller Governor Oil Line Removal (Engines with Rear-Mounted Propeller Governor Drives)

- A. Remove the bolt, lock washer, and washer from the clip on the propeller governor oil line (Figure 18). Discard the lock washer.
- B. Remove the clip.
- C. Remove the bolt, washer, lock washer, and nut that attach the clamp the sump and crankcase. Discard the lock washers.
- D. Discard the clamp.
- E. Disconnect the propeller governor oil line from the elbows at both ends.
- F. Remove the elbow fittings and O-ring from the 45° fitting. Discard the O-ring.
- G. Apply Food-Grade Anti-Seize to the threads of two plugs.
- H. Install one plug in the engine and the other plug in the propeller governor drive housing where the elbows were removed.
- I. Discard the propeller governor oil line.

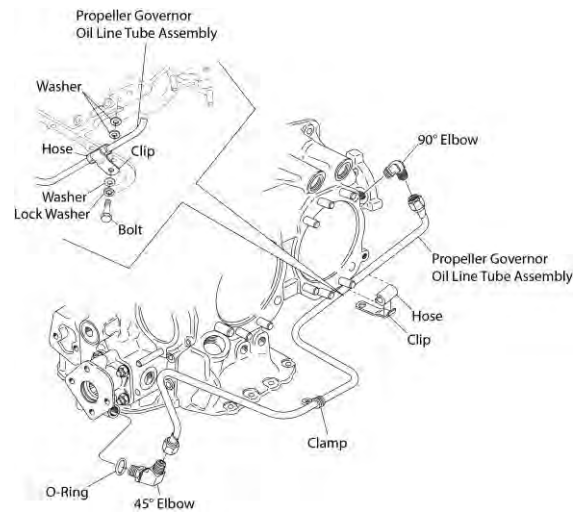


Figure 18
Propeller Governor Oil Line

20. Propeller Governor Oil Line Installation (Engines with Rear-Mounted Propeller Governor Drives)

- A. Install the 90° elbow fitting (if removed) in the propeller governor line boss at the front of the engine (Figure 19) as follows:
 - (1) Remove the plug in the engine and the plug in the propeller governor drive housing.
 - (2) Apply Loctite® #564 or equivalent to the threads of the fitting that installs in the engine.
 - (3) Torque the fitting to 10% less than torque requirements shown in Table 1.
 - (4) Torque to position the fitting as shown in Figure 19.



Figure 19
Propeller Governor Oil Line Fitting at the Front of the Engine

Table 1		
Fitting Torque Values		
Fitting size	Torque	
1/4 -18 NPT	85 in.-lb.	9.6 Nm
3/8-18 NPT	110 in.-lb.	12.4 Nm
1/2-14 NPT	160 in.-lb.	18.0 Nm

- B. Install the 45° elbow fitting with a new O-ring (if removed) in the propeller governor drive housing at the rear of the engine as follows:
 - (1) Apply engine oil to the threads of the fitting that install in the engine.
 - (2) Torque the coupling to position the fitting as shown in Figure 20 and to the torque value in Table 1.



Figure 20
Propeller Governor Oil Line Fitting on the Propeller Governor Drive Housing

- C. Install a new propeller governor oil line around the crankcase and sump and connect the oil line to the fittings in the front of the engine and the propeller governor drive housing. Do not torque yet.
- D. Install the hose and clip on the propeller governor oil line assembly (Figure 18).
- E. Attach the clip to the crankcase with the bolt, washers and a new lock washer. Torque the bolt to 17 ft.-lb. (23 Nm).
- F. Install a new clamp (Figure 18) on the propeller governor oil line assembly to the oil sump with the bolt, washer, new lock washer and nut. Torque the bolt to 96 in.-lb. (11 Nm).
- G. Torque the propeller governor oil line to the elbow fittings per the torque values in the latest revision of the *Service Table of Limits - SSP-1776*.

72-60 - ACCESSORY DRIVES

1. Accessory Drive Inspection
 - A. Look for defects in engine-mounted accessories such as pumps.
 - B. Make sure the vacuum pump driven gear and any attached accessories are attached securely at the correct torque. Refer to the latest revision of the *Service Table of Limits - SSP-1776* for torque values and tighten any loose hardware as necessary.

2. Vacuum Pump Replacement

A. Vacuum Pump Removal

Remove the vacuum pump (Figure 1) from the accessory drive housing in accordance with the aircraft manufacturer's instructions.



Figure 1
Vacuum Pump

B. Vacuum Pump Installation

Install the vacuum pump (Figure 1) on the accessory drive housing in accordance with the aircraft manufacturer's instructions.

3. Vacuum Pump Driven Gear Replacement

A. Vacuum Pump Driven Gear Removal

- (1) Remove the four nuts, lock washers, and washers from the vacuum pump adapter or vacuum pump cover (Figure 2). Discard the lock washers.

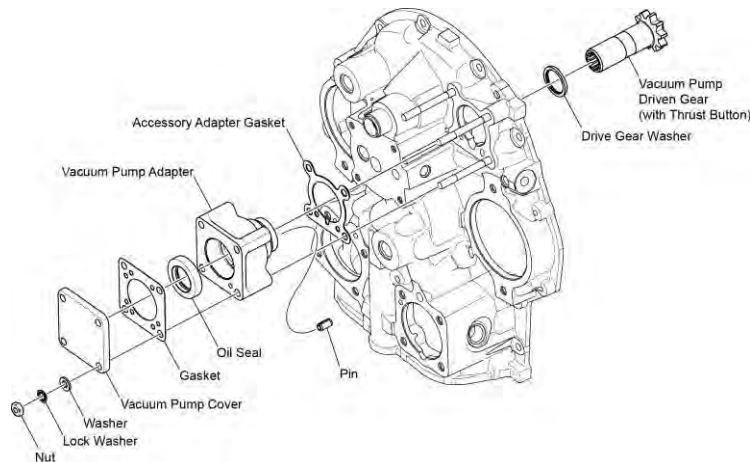


Figure 2
Vacuum Pump Drive and Cover

- (2) Remove the vacuum pump adapter or vacuum pump cover, gasket, and oil seal from the vacuum pump adapter. Discard the gasket and oil seal.
- (3) Remove the pin from the vacuum pump adapter. Discard the pin.
- (4) Remove the vacuum pump adapter, the accessory drive gasket, the drive gear washer from the vacuum pump driven gear. Discard the accessory drive gasket.
- (5) Remove the vacuum pump driven gear (and thrust button within the gear) from the accessory housing.
- (6) Remove any remaining gasket material from the vacuum pump adapter or vacuum pump cover, and accessory housing mounting surface.

B. Vacuum Pump Driven Gear Installation

- (1) Apply engine oil mixture to the vacuum pump driven gear.
- (2) Install the vacuum pump driven gear (with the thrust button already installed inside the geared end) on the accessory housing (Figure 2).
- (3) Install the drive gear washer on the vacuum pump driven gear.
- (4) Install a new pin in the vacuum pump adapter.
- (5) Install a new accessory adapter gasket on the vacuum pump adapter in the correct orientation as shown in Figure 2.
- (6) Apply a light coat of Loctite[®] 222 or equivalent to the vacuum pump adapter seal bore and install a new oil seal in the vacuum pump adapter seal bore.
- (7) Install the vacuum pump adapter with a new gasket on the vacuum pump driven gear as shown in Figure 2.
- (8) Install the vacuum pump or vacuum pump cover with a new gasket on the vacuum pump adapter with four nuts, four new lock washers and four washers. Torque the nuts to 96 to 108 in.-lb (11 to 12 Nm).

4. Propeller Governor Drive Replacement (Engines with Rear-Mounted Propeller Governor Drives)

A. Propeller Governor Drive Removal

- (1) If not already done, disconnect the propeller governor oil line from the fitting on the propeller governor drive adapter assembly per instructions in Chapter 72-50.

NOTICE: The propeller governor or propeller governor cover can be attached to the propeller governor drive adapter assembly (Figure 3) with either four bolts or four nuts on studs.

- (2) Remove the four nuts or bolts, four lock washers, and four washers from the propeller governor or propeller governor cover (Figure 3). Discard the lock washers.

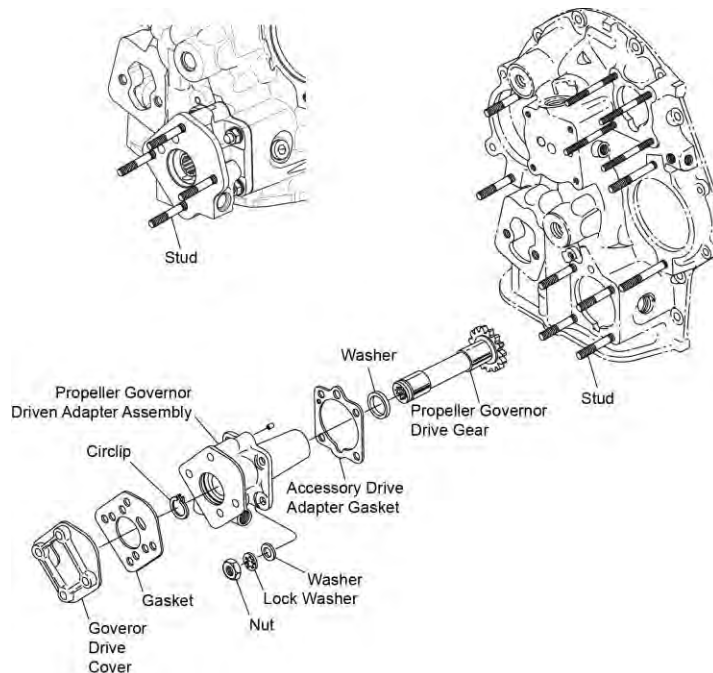


Figure 3
Propeller Governor Drive Adapter Assembly

- (3) Remove the propeller governor or propeller governor cover and governor gasket from the propeller governor drive adapter assembly. Discard the gasket.
- (4) Remove the four nuts, lock washers, and washers from the studs in the accessory housing (Figure 3). Discard the lock washers.
- (5) Remove the propeller governor driven adapter assembly and accessory drive adapter gasket from the accessory housing. Discard the gasket.
- (6) Remove the propeller governor drive gear from the propeller governor drive assembly.
- (7) Remove any remaining gasket material from the propeller governor or propeller governor cover, propeller governor driven adapter, and accessory housing mounting surface.

B. Propeller Governor Drive Installation

- (1) Lubricate the propeller governor drive gear with engine oil mixture.
- (2) Install the gear into propeller governor drive assembly. Refer to Figure 4.



Figure 4
Propeller Governor Driven Adapter Assembly

- (3) Install the pin (Figure 3) in the propeller governor drive assembly (if removed).
- (4) Install the propeller governor drive adapter assembly in the accessory housing with a new accessory drive adapter gasket (Figure 3).
- (5) Install the four nuts on the studs with washers and new lock washers. Torque the nuts to 17 to 19 ft.-lb. (23 to 26 Nm).
- (6) If studs are installed in the propeller governor driven adapter assembly (Figure 3):
 - (a) Install the propeller governor or propeller cover with a new governor gasket on the propeller governor drive assembly.
 - (b) Install the four nuts on the studs with washers and new lock washers. Torque the nuts to 17 to 19 ft.-lb. (23 to 26 Nm).
- (7) If studs are not installed in the propeller governor drive adapter assembly (Figure 3):
 - (a) Examine the Heli-Coil® inserts in the propeller governor drive adapter assembly. Replace damaged Heli-Coil® inserts.
 - (b) Install the propeller governor or propeller governor cover with a new governor gasket on the propeller governor drive assembly.
 - (c) Install the four bolts with washers and new lock washers. Torque the nuts to 17 to 19 ft.-lb. (23 to 26 Nm).

This page intentionally left blank.

72-70 - ELECTRICAL SYSTEM MAINTENANCE

1. Wiring Inspection

- A. Examine the aircraft electrical wiring for correct routing, security, clamping, deterioration, and chafing in accordance with the aircraft manufacturer's instructions. If wires are worn, chafed, or frayed take corrective action in accordance with the aircraft manufacturer's instruction.
- B. Make sure the wiring connections are tight. Tighten any loose wiring connections.

2. Alternator Belt Inspection

NOTICE: There either can be a single alternator or dual (twin) alternators.

- A. Examine the alternator belt(s) (Figure 1) for any cracks, damage, or wear.
- B. Complete the "Alternator Belt Tension Check/Adjustment" procedure in this chapter.
- C. Replace a worn, cracked or damaged alternator belt.

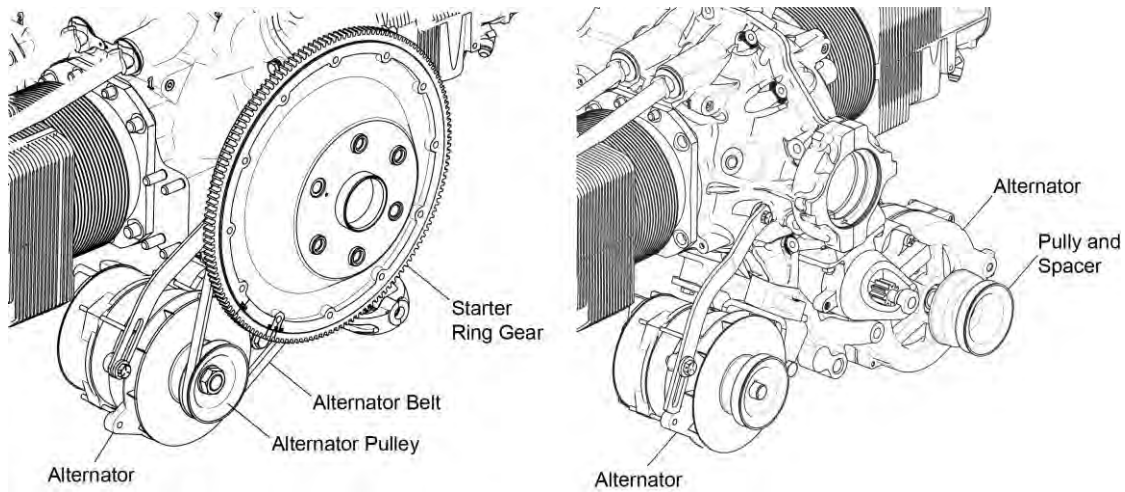


Figure 1
Alternator and Alternator Belt

3. Alternator Belt Tension Check/Adjustment

⚠ CAUTION: IF THE ALTERNATOR BELT TENSION IS NOT SET CORRECTLY, THE ALTERNATOR BELT CAN SLIP, WEAR PREMATURELY, AND FAIL.

- A. When to complete an alternator belt tension check.
 - (1) Immediately after the alternator belt is replaced and then after 25 hours of operation after alternator belt installation.
 - (2) During each 100-hour service inspection thereafter.
- B. Use any of the following three methods to complete an alternator belt tension check:
 - Torque Method
 - Deflection Method
 - Belt Tension Dial Gage Method

NOTICE: Refer to the latest revision of Service instruction SI-1129 for any new details on alternator belt tension check.

- (1) Torque Method (measure the torque required to slip the belt at the small pulley as follows):
 - (a) Hold and secure the propeller to prevent rotation of the crankshaft.
 - (b) Apply a torque indicating wrench to the nut that attaches the pulley to the alternator and turn it clockwise.
 - (c) Record the torque value on the torque indicating wrench to slip the belt(s) at the small pulley.
 - (d) Adjust the belt tension as per the required torque values that correspond to a new or used belt identified in Table 1.

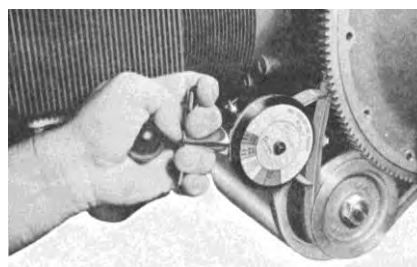
**Table 1
Required Torque (Belt Tension)**

Width of Belt	Condition of Belt	Torque at Pulley		Condition of Belt	Torque at Pulley	
		ft.-lb	Nm		ft.-lb	Nm
3/8 inch	New	11 to 13	15 to 18	Used*	7 to 9	10 to 12
Twin 3/8 inch	New	22 to 26	30 to 35	Used*	14 to 18	19 to 24
½ inch	New	13 to 15	18 to 20	Used*	9 to 11	12 to 15
11 millimeter	New	22 to 24	30 to 33	Used*	15 to 17	20 to 23

* A belt is considered used if it has been installed on the engine and the engine has been operated.

- (2) Deflection Method
 - (a) Attach the hook of a small spring-scale to the alternator belt at the approximate mid-point between the ring gear support and the alternator.
 - (b) Pull on the scale until a reading of 14 lb (6.4 kg), is shown for a new belt, 10 lb. (4.5 kg) for a used belt.
 - (c) Measure the distance the alternator belt has moved with the 10 or 14 lb. (4.5 to 6.4 kg) load applied.
 - (d) The distance (deflection) is to be 5/16 in. (7.94 mm). If less than 5/16 in. (7.94 mm), the alternator belt tension is too tight.
 - (e) Adjust the belt tension as required for 5/16 in. (7.94 mm) distance (deflection) per the “Alternator Belt Tension Adjustment” procedure in this chapter.
- (3) Belt Tension Dial Gage Method (using Lycoming tool number ST-131 (Figure 2):

- (a) Extend the hook on the Belt Tension Dial Gage ST-131 (Figure 2) to its extreme position by depressing the handle.
- (b) Put the hook over the alternator belt with the nose piece centered on the alternator belt.



**Figure 2
Belt Tension Dial Gage - ST-131**

NOTICE: In the next step, release the handle of the Belt Tension Dial Gage (ST-131) quickly. If the handle is released slowly, internal friction will cause an inaccurate reading.

- (c) Quickly release the handle of the Belt Tension Dial Gage (ST-131) and read the indicated belt tension on the dial (Figure 3).
- (d) Repeat the previous steps several times to ensure an accurate reading.
- (e) If the tension reading on the alternator belt is out of tolerance, adjust the belt tension per the “Alternator Belt Tension Adjustment” procedure for the respective alternator in this chapter to get the appropriate reading on the Belt Tension Dial Gage (ST-131).



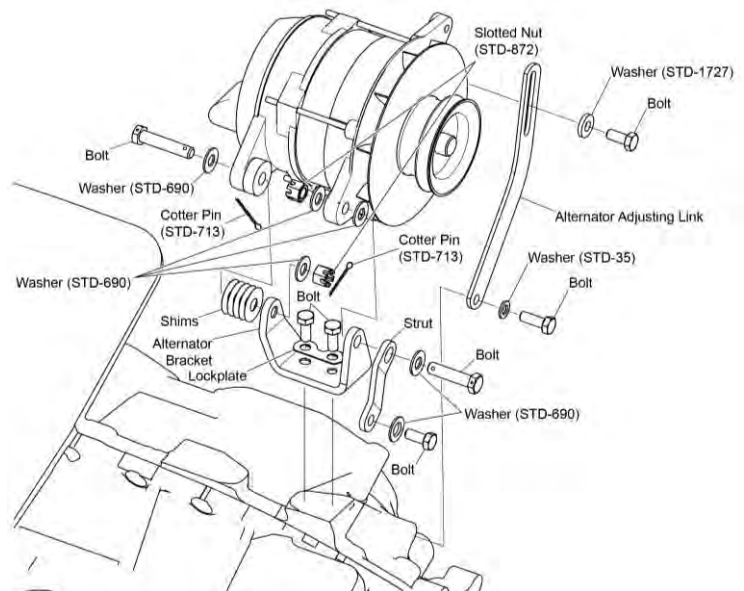
**Figure 3
Indicator on the
Belt Tension Dial Gage (ST-131)**

C. Alternator Belt Tension Adjustment

- (1) Cut and remove the safety wire from the alternator adjusting link where shown in Figure 4.
- (2) Loosen the bolt that attaches the alternator adjusting link to the alternator (Figure 5).
- (3) Loosen the bolt that attaches the alternator adjusting link to the crankcase.
- (4) Rotate the alternator on the bracket to adjust the alternator belt tension.
- (5) Torque the two bolts on the alternator adjusting link to 17 ft.-lb. (23 Nm).
- (6) Torque the idler pulley nut to 75 ft.-lb. (101 Nm).
- (7) Complete the “Alternator Belt Tension Check/Adjustment” procedure per the applicable method in this chapter.
- (8) Install new safety wire on the cotter pins and two bolts on the alternator adjusting link as shown in Figure 4.



**Figure 4
Safety Wire on Bolts of
Alternator Adjusting Link**



**Figure 5
Alternator and Alternator Bracket**

4. Alternator and Bracket Removal

⚠ CAUTION: DISCONNECT THE BATTERY AND ENSURE MAGNETOS ARE PROPERLY GROUNDED TO PREVENT ELECTRICAL SHOCK AND ACCIDENTAL ENGINE START.

A. To remove the alternator:

- (1) Cut and remove the safety wire/cable from the two bolts on the alternator adjusting link where shown in Figure 4.
- (2) Remove the two bolts and two different washers (STD-1727 and STD-35) from the alternator adjusting link (Figure 5).
- (3) Remove the alternator adjusting link.
- (4) Remove the two cotter pins (STD-713), two bolts, two slotted nuts, shims and three washers from the alternator bracket, strut, and alternator (Figure 5). Discard the cotter pins and slotted nuts.
- (5) Remove the alternator and alternator belt.

B. To remove the alternator bracket:

- (1) Remove the two bolts and lockplate from the alternator bracket (Figure 5).
- (2) Remove the two bolts and washer (STD-690) from the strut and alternator bracket.
- (3) Remove the strut and alternator bracket.

5. Alternator and Bracket Installation

A. To install the alternator bracket:

- (1) Mount the alternator bracket on the engine.
- (2) Install the lockplate with two bolts and washers on the alternator bracket (Figure 5). Torque the bolts to 17 ft.-lb. (23 Nm).
- (3) Bend the tabs of the lockplate against the bolts.
- (4) Attach the strut to the alternator bracket with the two bolts and washers. Torque the bolts in accordance with the latest revision of the *Service Table of Limits SSP - 1776*.

B. To install the alternator:

NOTICE: Refer to the latest revision of Service Instruction No. SI-1154 to ensure the correct approved alternator for your engine is to be installed.

- (1) Mount the alternator on the alternator bracket (Figure 5).
- (2) Install the bolt, two new slotted nuts, shims (as many as necessary) and three washers on the alternator bracket and alternator as shown in Figure 5. Install a new cotter pin (STD-713) in each new slotted nut.
- (3) Install the alternator adjusting link with the two bolts and different washers (STD-1727 and STD-35) where shown in Figure 5.
- (4) Examine the alternator belt per “Alternator Belt Inspection” in this chapter.
- (5) Install the alternator belt on the alternator per the “Alternator Belt Installation” procedure in this chapter.
- (6) Install safety wire/cable on the cotter pin and the alternator adjusting link as shown in Figure 4.

6. Alternator Belt Replacement

A. Alternator Belt Removal

- (1) Remove the safety wire from both bolts on the alternator adjusting link (Figure 4).
- (2) Loosen the bolt that attaches the alternator adjusting link to the alternator (Figure 5).
- (3) Loosen the bolt that attaches the alternator adjusting link to the crankcase (Figure 5).
- (4) Rotate the alternator on the bracket towards the starter ring gear.
- (5) Remove the alternator belt from the alternator pulley and the starter ring gear (Figure 6).

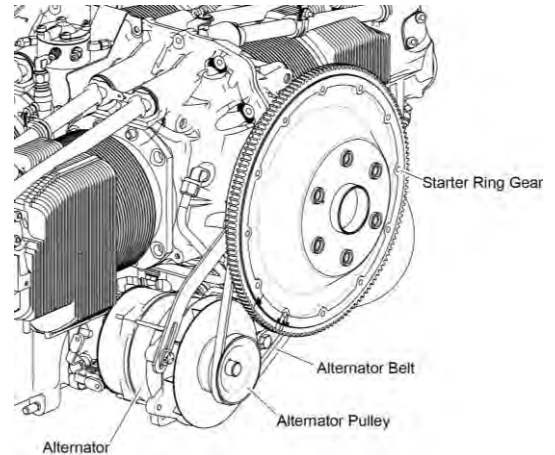


Figure 6
Alternator and Alternator Belt

B. Alternator Belt Installation

- (1) Install the alternator belt in the alternator belt groove on the starter ring gear support.
- (2) Install the alternator belt in the groove on the alternator pulley (Figure 6).
- (3) Adjust the alternator belt tension. Refer to the “Alternator Belt Tension Check/Adjustment” procedure in this chapter.
- (4) Torque the bolts that attach the alternator adjusting link to the alternator and to the crankcase to (Figure 5) to 17 ft.-lb. (23 Nm).
- (5) Install new safety wire/cable on the two bolts on the alternator adjusting link as shown in Figure 4.

7. Starter Replacement

A. Starter Removal

- (1) Disconnect all power to the engine.
- (2) Remove electrical leads from the starter. Refer to the airframe manufacturer's manual.
- (3) Remove the bolt and lock washer, from the starter (Figure 7). Discard the lock washer.
- (4) Hold the starter and remove the three nuts and lock washers from the studs on the mounting face for the starter. Discard the lock washers.
- (5) Remove the starter from the studs on the engine.

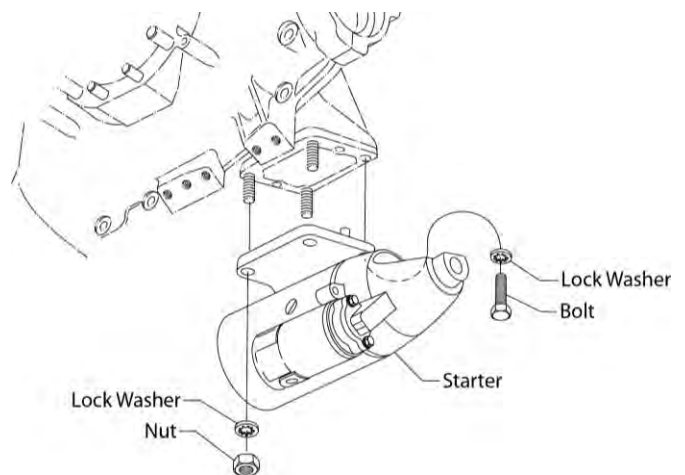


Figure 7
Starter

B. Starter Installation

NOTICE: Refer to the latest revision of Service Instruction No. SI-1154 to ensure the correct approved starter for your engine is to be installed.

- (1) Install the starter onto studs and seat on mounting face of the engine (Figure 7).
- (2) Install the starter with a new lock washer and a nut on each of the three studs.
- (3) Install the bolt, a new lock washer, and a flat washer in the vacated hole on the engine mounting face of the starter.
- (4) Tighten and torque the bolt and all of the nuts per the Standard Torque Tables in the latest revision of the *Service Table of Limits - SSP-1776*.
- (5) Install electrical leads to the starter as per the airframe manufacturer's manual.
- (6) Restore power to the engine.
- (7) Complete the operational test in Chapter 72-00, to make sure the starter operates correctly.

8. Starter Ring Gear Support Replacement

A. Starter Ring Gear Support Removal

- (1) If not already done, release the tension on the alternator belt(s).

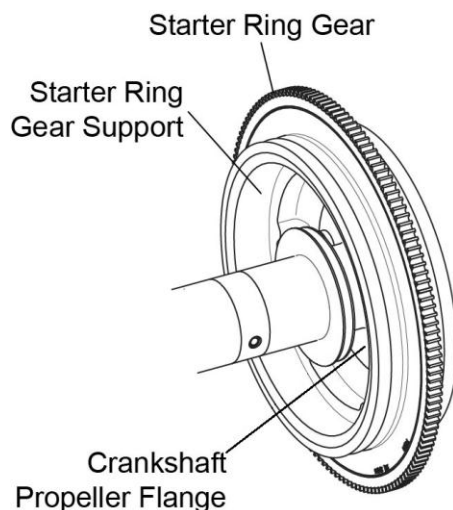


Figure 8
Starter Ring Gear Support

- (2) Remove the alternator belts from the starter ring gear support (Figure 8).
- (3) Remove the starter ring gear support from the crankshaft propeller flange.

B. Starter Ring Gear Support Installation

- (1) Install the alternator belts in the pulley of the starter ring gear support.
- (2) Assemble the ring gear support over the propeller flange bushings.
- (3) Locate the starter ring gear so that the "0" on the ring gear support aligns with the "0" on the crankshaft flange.

- (4) Align the mark on the crankshaft flange (Figure 9) with the mark on the starter ring gear assembly (Figure 10). Install the starter ring gear on the crankshaft flange.

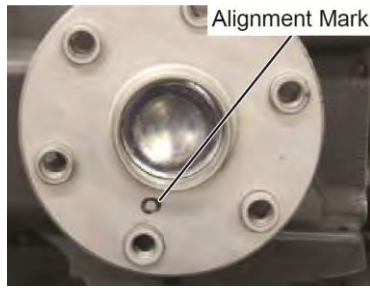


Figure 9
Alignment Mark
on the Crankshaft Flange

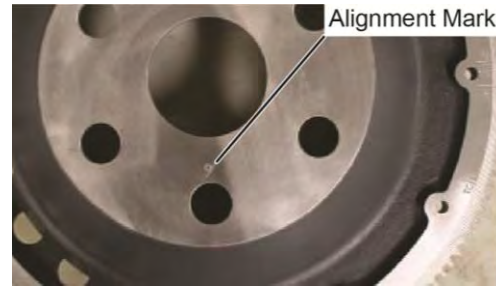


Figure 10
Alignment Mark on the Starter Ring Gear

9. Starter Ring Gear Replacement

NOTICE: The following procedure is for replacing a worn or damaged starter ring gear without replacing the starter ring gear support. Refer to the latest revision of Service Instruction No. SI-1141.

A. Starter Ring Gear Removal

- (1) Make sure that none of the propeller bolt holes in the starter ring gear support are worn or out-of-round.
- (2) If you find defective holes, replace the entire starter ring gear assembly.

⚠ CAUTION: DO NOT GRIND INTO THE STARTER RING GEAR SUPPORT. IF YOU GRIND INTO THE STARTER RING GEAR SUPPORT, IT MUST BE REPLACED.

- (3) If the propeller bolt holes are satisfactory, grind through the ring gear until there is only a thin ring of gear metal. Do not grind into the starter ring gear support.
- (4) Put the starter ring gear on a flat metal surface and break the thin metal ring from the grinding operation. The starter ring gear will spring open for easy removal.

B. Starter Ring Gear Inspection

Examine the starter ring gear face for damage and missing or damaged teeth. If the ring gear is damaged, replace it per instructions in this chapter. Do not use it again.

C. Starter Ring Gear Installation

- (1) Put the starter ring gear support on a flat surface (Figure 11) with the alternator/generator belt groove upward.

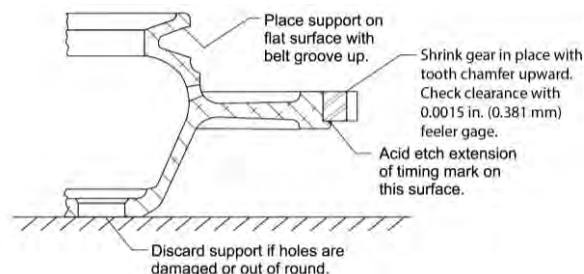


Figure 11
Starter Ring Gear Support

- (2) Heat the new starter ring gear to approx. 450°F (232°C) in an oven or with a torch.
- (3) Assemble the heated gear on the ring gear support (with the tooth chamfer up).

NOTICE: As the starter ring gear cools, it will shrink to the support.

- (4) Use a 0.0015 in. (0.0381 mm) feeler gage to measure the clearance between the ring gear and support at both locations where the ring gear and support surfaces make contact. Measure around the entire circumference. The clearance measurements must be same to ensure correct seating of the ring gear against the support face. Different clearance measurements are an indication of incomplete assembly or warpage and must be corrected.
- (5) Install the starter ring gear support with the new starter ring gear on the crankshaft flange per the “Starter Ring Gear Support Installation” section in this chapter.

72-80 - INDUCTION SYSTEM MAINTENANCE

1. Induction System Inspection

- A. Examine the air intake pipes (Figure 1) for leaks, security.

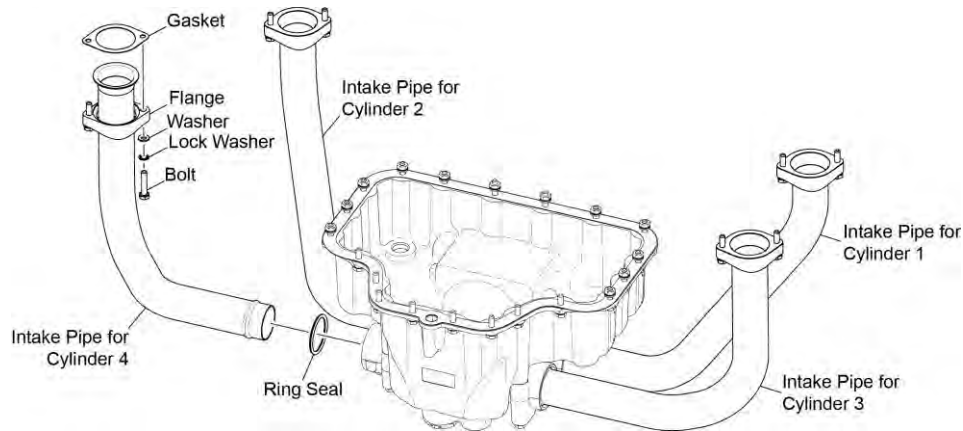


Figure 1
Intake Pipes and Attaching Parts

- B. Examine the air filter for damage.
- C. Service in accordance with the manufacturer's service procedure. Evidence of dust or other solid material in the ducts is indicative of inadequate air filter care or a damaged air filter.

⚠ CAUTION: TAKE PRECAUTIONS IN THE NEXT STEP, IF VOLCANIC ASH IS SUSPECTED ON THE ENGINE, DO NOT TOUCH IT WITH BARE HANDS OR GET IT IN YOUR EYES. THE VOLCANIC ASH CAN CONTAIN ACIDIC COMPOUNDS WHICH MUST NOT BE INHALED OR TOUCHED SINCE IT CAN CAUSE INJURY. DO NOT USE WATER TO RINSE IT OFF. WEAR PERSONAL PROTECTIVE EQUIPMENT. REFER TO THE SECTION "VOLCANIC ASH/PARTICULATE CONTAMINATION" IN CHAPTER 05-50.

- D. If there is dust (other than volcanic ash) or other solid material in the air ducts, remove the dust and contaminant, examine the air filter and replace the air filter if necessary. Identify the cause of the problem per the aircraft Original Equipment Manufacturer (OEM) procedure.
- E. Identify and correct the cause of the problem per the aircraft manufacturer's instructions.

2. Intake Pipe Replacement

NOTICE: Each engine cylinder has a corresponding intake pipe of a different part number. Be sure to replace the intake pipe with the replacement intake pipe of the correct part number that corresponds to the engine cylinder number (Figure 1).

A. Intake Pipe Removal

- (1) Remove the two bolts, lock washers, and washers from the intake pipe flange at the engine cylinder (Figure 1). Discard the lock washers.
- (2) Remove the gasket from the intake pipe, discard the gasket.
- (3) If the intake pipe is not to be replaced, attach a label to the intake pipe that identifies the corresponding engine cylinder number for reference on assembly.
- (4) Pull the intake pipe and ring seal from the oil sump. Discard the ring seal.

B. Intake Pipe Installation

NOTICE: Since there is a corresponding intake pipe for each engine cylinder, make sure the intake pipe of the correct part number is installed for the respective engine cylinder.

- (1) Apply a coating of clean engine oil to a new ring seal.
- (2) Install a new ring seal in the groove in the oil sump (Figure 1).
- (3) Push the intake pipe into the oil sump until it seats.
- (4) Attach the corresponding intake pipe centered on the correct engine cylinder flange with a new gasket, two bolts, two new lock washers, and two washers. Torque the two bolts to 96 to 108 in.-lb. (11 to 12 Nm).

3. Fuel Drain Valve Adapter Assembly Inspection

The fuel drain valve adapter assembly (Figure 2) is a valve in the induction system that closes during engine operation and opens when the engine is shut down to allow excess fuel to drain from the induction system. If the valve is not operating correctly it can either allow outside air into the induction system during engine operation or fail to drain excess fuel from the induction system when the engine is shut down.

If your engine has a fuel drain valve adapter assembly installed, examine the assembly as follows:

- A. Remove the fuel drain valve adapter assembly from the induction system.
- B. Examine the fuel drain valve adapter assembly for damage.
- C. Make sure the fuel drain valve adapter assembly is operating correctly:
 - (1) The valve is operating correctly if it is open with no air pressure applied.
 - (2) The valve is operating correctly if it closes when 0.75 to 1.0 psi (5.2 to 6.9 kPa) of air pressure is applied to the outboard side of the fuel drain valve adapter assembly.
- D. If the valve is not operating correctly or if the fuel drain valve adapter assembly is damaged, replace the fuel drain valve adapter assembly.
- E. Apply a coating of Loctite[®] 564 thread sealant or equivalent to the threads of a serviceable fuel drain valve adapter assembly.
- F. Install the fuel drain valve adapter assembly in the oil sump. Torque the assembly to 40 in.-lb. (4.5 Nm).

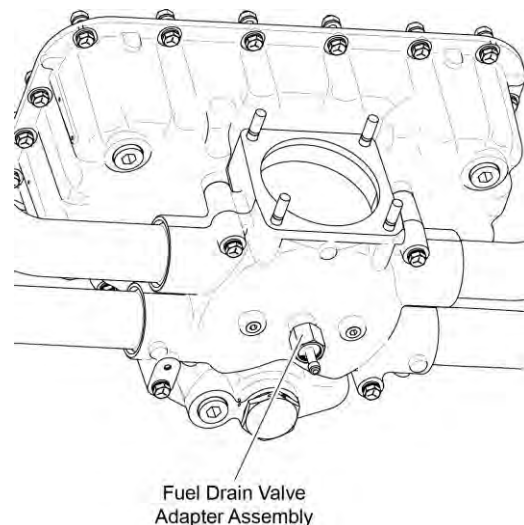


Figure 2
Fuel Drain Valve Adapter Assembly

73-10 - ENGINE FUEL AND CONTROL – DISTRIBUTION MAINTENANCE

1. Fuel System Inspection

⚠ WARNING: DO NOT SMOKE OR HAVE AN OPEN FIRE/FLAME OR USE ANY DEVICES THAT CAN MAKE SPARKS DURING THIS INSPECTION. FLAMES OR SPARKS CAN CAUSE FUEL IGNITION WHICH CAN CAUSE SERIOUS BURNS, INJURY, OR DEATH.

⚠ CAUTION: TO ENSURE CORRECT ENGINE OPERATION AND FLIGHT SAFETY, THERE MUST NOT BE ANY FUEL LEAK AND ALL FUEL LINES MUST BE SECURED WITH CLAMPS (PER THE “FUEL LINE INSPECTION” PROCEDURE IN THIS CHAPTER). IDENTIFY AND CORRECT THE CAUSE OF ANY FUEL LEAK.

NOTICE: This inspection is to be done every 100 hours.

- A. Make a copy of the Fuel System Inspection Checklist at the end of this chapter and complete this checklist for this inspection.

NOTICE: Figure 1 is a general conceptual reference figure of fuel system components. Some of the IO-390-C engine models contain fuel system components made up of different configurations and part numbers. Refer to the applicable latest edition of the *IO-390-C Series Engines Illustrated Parts Catalog* for part number details.

- B. Examine the fuel pump for secure attachment and damage. Replace a damaged or malfunctioning fuel pump. Tighten any loose fasteners per the “Fuel Pump Replacement” procedure in this chapter.
- C. Examine the fuel manifold (Figure 1) for damage, leaks, and loose fittings or connections. Tighten any loose fittings or connection. Replace a damaged fuel manifold per the “Fuel Manifold Replacement” procedure in this chapter.
- D. Examine the fuel injector for damage, leaks, and loose fittings or connections. Tighten any loose fittings or connection per the “Fuel Injector Installation” procedure in this chapter. Replace a damaged fuel injector per the “Fuel Injector Replacement” section in this chapter.
- E. Examine each injection nozzle (Figure 1) for damage or wear; replace a damaged or worn injection nozzle per the “Injection Nozzle Replacement” procedure in this chapter.
- F. Examine fuel line fittings for damage or leaks. Make sure all fuel line fittings and connections are secure and correctly installed/torqued per the “Fuel Line Installation” procedure in this chapter. If tightening does not correct a fuel leak, replace the fitting.
- G. Complete the “Fuel Line Inspection” procedure in this chapter.
- H. Make sure the mixture control and throttle linkage have full travel, freedom of movement.
- I. Lubricate the linkage per the aircraft manufacturer's instruction.
- J. Operate the engine and look for leaks. Identify and correct the cause of any leak or malfunction. If leaks or malfunctions were found and corrected, operate the engine again to make sure it is operating correctly and there is no leak anywhere.
- K. Do not return the engine to service unless the engine is operating correctly and does not have any leaks.

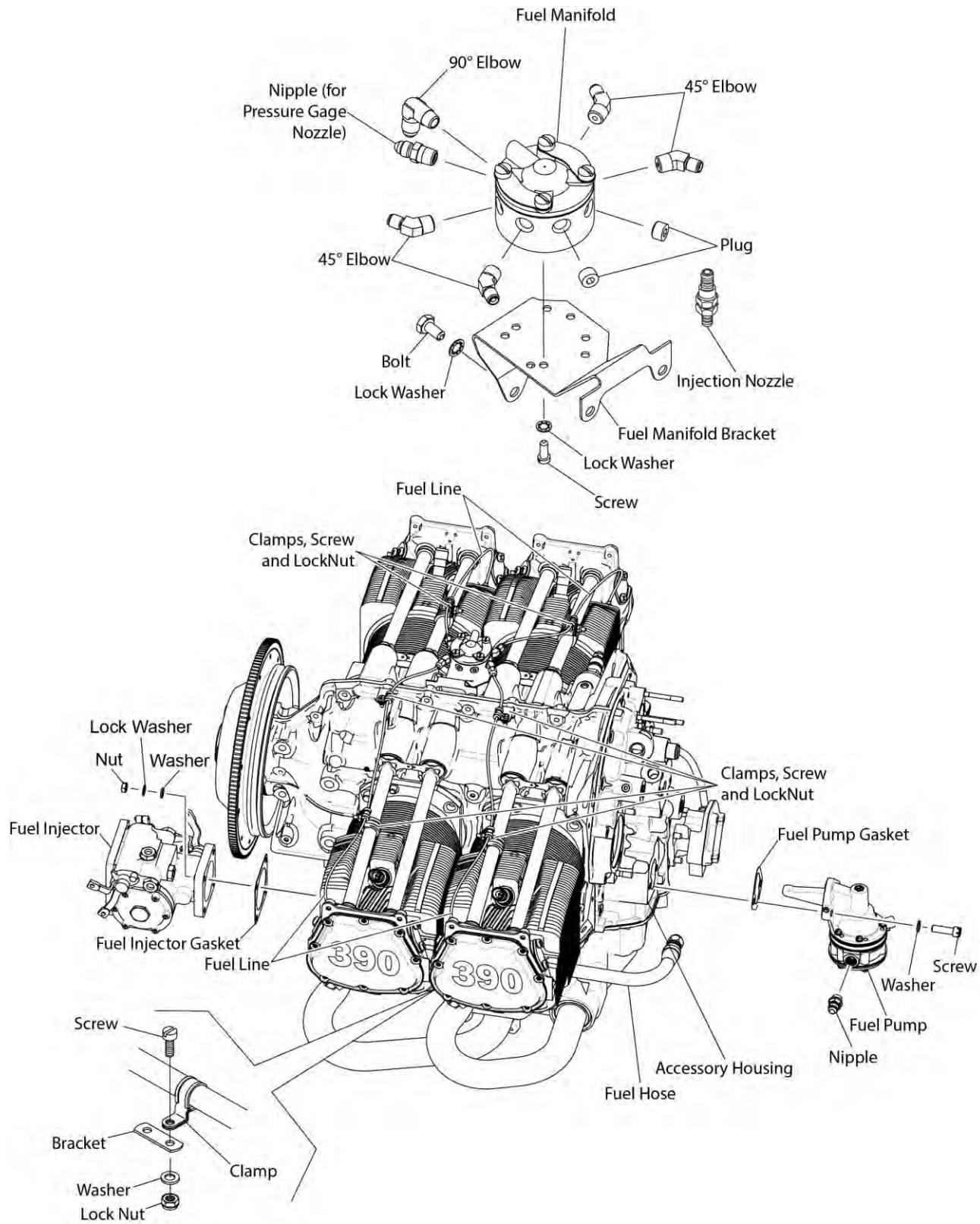


Figure 1
Fuel System Components

2. Fuel Line Inspection

⚠ WARNING: DO NOT SMOKE OR HAVE AN OPEN FIRE/FLAME OR USE ANY DEVICE THAT CAN MAKE SPARKS DURING THIS INSPECTION. FLAMES OR SPARKS CAN CAUSE FUEL IGNITION WHICH CAN CAUSE SERIOUS BURNS, INJURY, OR DEATH.

⚠ CAUTION: TO ENSURE CORRECT ENGINE OPERATION AND FLIGHT SAFETY, THERE MUST NOT BE ANY FUEL LEAK AND ALL FUEL LINES MUST BE SECURED WITH CLAMPS (PER THIS INSPECTION). IDENTIFY AND CORRECT THE CAUSE OF ANY FUEL LEAK.

NOTICE: This fuel line inspection is to be done during every visual inspection and any time fuel lines or clamps are serviced, removed, or replaced. Copy and record findings in the Fuel System Inspection Checklist in this chapter.

A. There are four fuel lines on this engine (Figure 2). For reference, identify each fuel line by number to the corresponding cylinder.

NOTICE: Figures 2A, 2B, and 2C are general conceptual reference figures of fuel line and hose configurations, clamps, brackets, and fasteners for the various fuel injected 390-C series engine models. Your fuel line/hose routing could be different. Part numbers can vary between the different engine models. Refer to the applicable latest edition of the *IO-390-C Series Engines Illustrated Parts Catalog* for part number details.

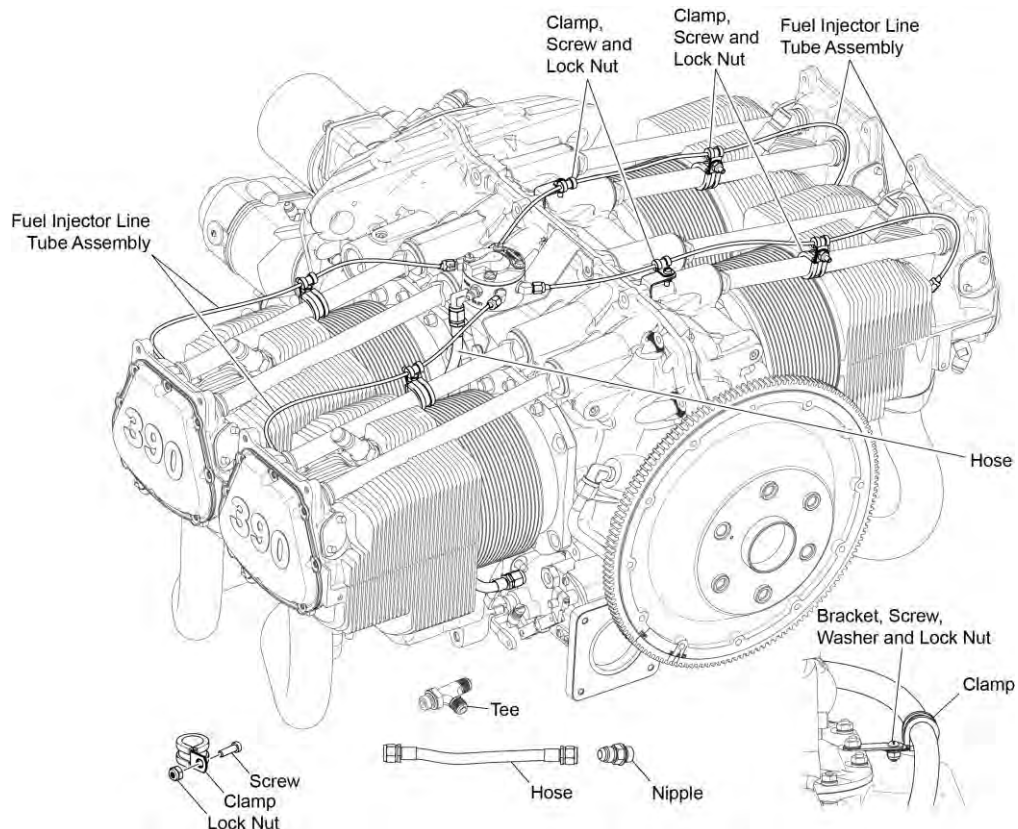


Figure 2A
Example of Fuel Line Configuration

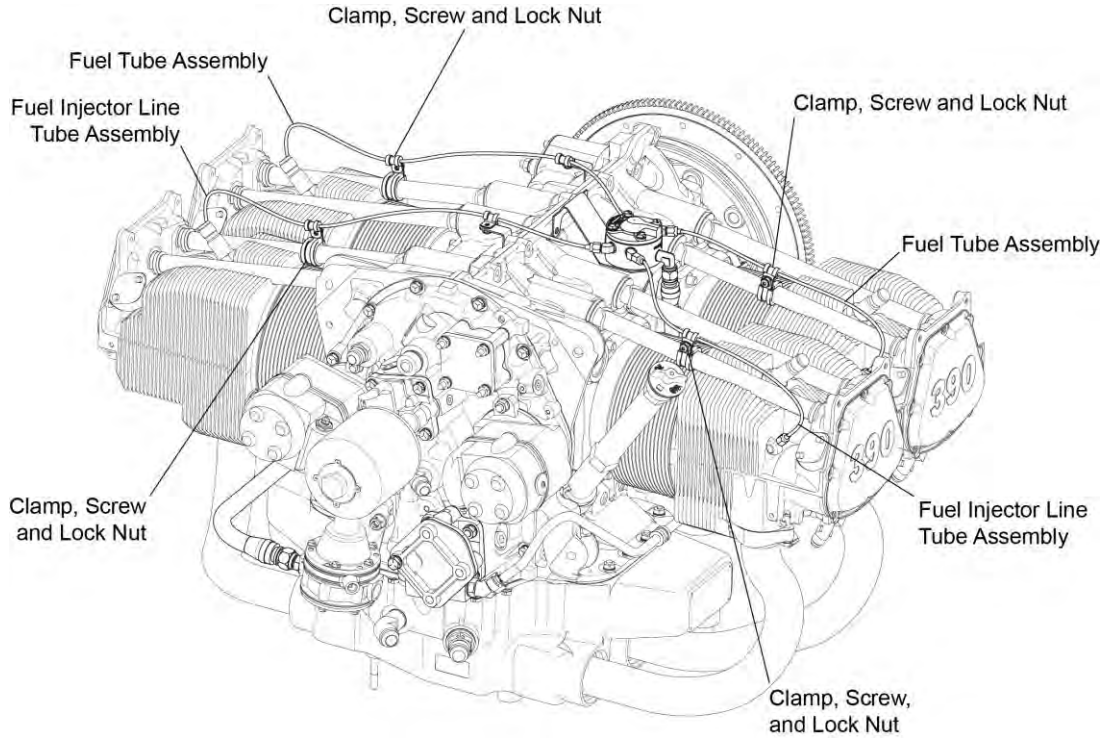


Figure 2B
Example of Fuel Line Configuration

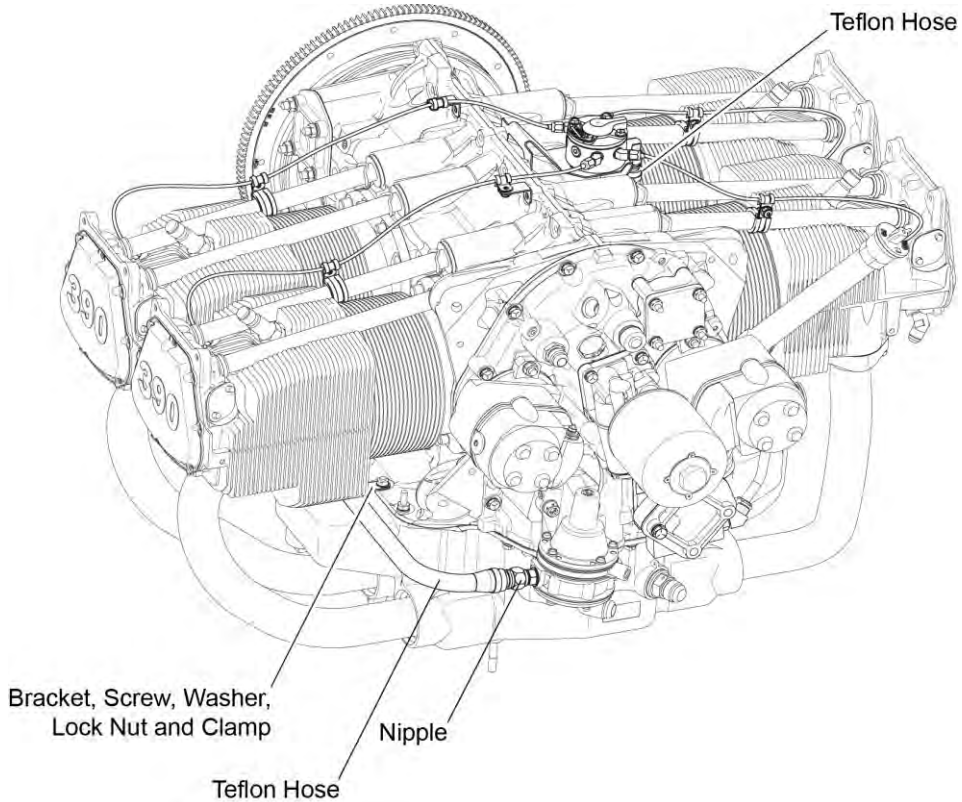


Figure 2C
Example of Fuel Line Configuration

- B. Examine each fuel line for damage, leaks, dents, pits, nicks, kinks, stains (from fuel leaks), cracks, brittleness, nearby heat sources, chafing, looseness, crimped, kinked, or sharp bends. Refer to Figure 3 which shows the minimum acceptable dimensions for a bend in the fuel line. Replace (do not try to repair) a worn, damaged, chafed, brittle, crimped, sharply bent, kinked, or loose fuel line. (A loose fuel line could have been subjected to vibrational forces and be weakened. Cracks can develop at kinks in fuel lines.)

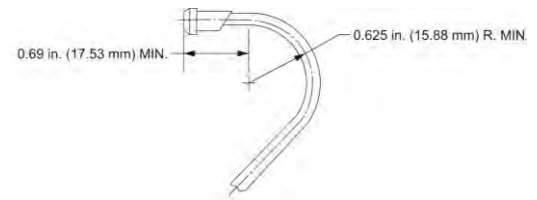


Figure 3
Minimum Acceptable Dimension
for a Bend in a Fuel Line

- ⚠ CAUTION:** TO SUPPORT FUEL SYSTEM PERFORMANCE, ALL WORN, DAMAGED, CHAFED, BRITTLE, KINKED, OR LOOSE FUEL LINES MUST BE REPLACED - NOT REPAIRED.

MAKE SURE EACH FUEL LINE IS INSTALLED WITH SERVICEABLE CUSHIONED CLAMPS TO KEEP THE FUEL LINES SECURELY IN PLACE TO PREVENT FUEL LINE DAMAGE DUE TO VIBRATION AND FRICTION AGAINST OTHER PARTS OF THE ENGINE. VIBRATION, RUBBING, AND/OR KINKS IN THE FUEL LINES CAN CAUSE CRACKS IN THE FUEL LINES. AS A RESULT, THE FUEL LINES CAN EVENTUALLY BREAK, LEAK FUEL ON THE ENGINE, AND CAUSE A FIRE OR ENGINE STOPPAGE.

- C. Make sure all fuel lines are held in place securely using serviceable cushioned clamps to prevent fuel line movement due to vibration.
- (1) Make sure each clamp securely supports the fuel line to prevent fuel line movement due to vibration, friction, or motion frequencies. **Do NOT use plastic tie straps as clamps.**
 - (2) Examine the cushion on clamps for deterioration. If cushions are deteriorated or missing, replace the clamp with a new clamp with the cushion intact.
 - (3) On engines that use metal clamps with no cushion, install a fuel line sleeve at each clamp location.
 - (4) **If a fuel line had been in service and clamps were not installed, replace the fuel line with a new fuel line (as a precaution since vibration can cause cracks in the fuel lines.)**
 - (5) Make sure the clamps are securely attached. If the clamps are loose, replace the fuel line.

- ⚠ CAUTION:** REPLACE ANY FUEL LINE THAT IS CRACKED, DENTED, OR KINKED; CRACKS CAN DEVELOP AT THE SITE OF SHARP BENDS OR KINKS.

- D. Examine solder joints at the end of fuel lines for cracks. Replace the fuel line if a crack is found at a solder joint.

- ⚠ WARNING:** DO NOT ROUTE FUEL LINES CLOSE TO HEAT SOURCES. HEAT CAN CAUSE FUEL VAPORIZATION IN THE FUEL LINES OR CAN DAMAGE THE FUEL LINE AND CAUSE A FUEL LEAK WHICH COULD LEAD TO ENGINE STOPPAGE.

⚠ CAUTION: DO NOT RETURN THE ENGINE TO SERVICE UNLESS THE ENGINE IS OPERATING CORRECTLY AND DOES NOT HAVE ANY LEAKS. THERE MUST NOT BE ANY FUEL LEAKS. A FUEL LEAK CAN CAUSE A FIRE.

- E. Make sure no fuel lines touch the engine or aircraft baffle hardware. There must be a minimum clearance of 3/16 in. (4.76 mm) between a fuel line and any engine or aircraft surface.
- F. After the inspection, refer to Table 1 for any corrective action if necessary.

**Table 1
Corrective Action for Fuel Lines**

Condition	Corrective Action
Leaky, cracked, brittle, worn, chafed, fuel line Bent (non-kinked) stainless steel fuel lines that have an inside radius less than 5/8 in. (15.88 mm)	Do NOT repair any fuel line that leaks or is cracked, brittle, worn, or chafed. Replace the fuel line with a new fuel line.*
Damaged, pitted, nicked, dented, loose, crimped or kinked fuel line or fuel line with sharp bends greater than that shown in Figure 3	Do NOT re-use any fuel line that is damaged, dented, pitted, crimped, or kinked. Dents can cause cracks to form. Replace the fuel line with a new fuel line.*
No clamps installed on fuel line that had been in service	Replace the fuel line with a new fuel line and install serviceable cushioned clamps on the fuel line to securely hold the fuel line in place and prevent fuel line movement from vibration.*
Loose clamps	Replace the fuel line with a new fuel line and install serviceable cushioned clamps on the fuel line to securely hold the fuel line in place and prevent fuel line movement from vibration.*
Deteriorated cushion on clamp, missing cushion, or cushion does not completely cover the fuel line diameter. (On engines that used metal clamps with no cushion, use the P/N LW-12598 fuel line sleeve at each of those clamping locations. The fuel line sleeve is not used with the cushioned clamps.)	Examine fuel lines in areas adjacent to the clamp. Replace any fuel line that has any conditions identified above.* Replace the clamp with a new serviceable cushioned clamp.
Problem with fuel injector clamp installation caused by obstructive baffling	Install the fuel injector clamps to enable clearance.
* Refer to the “Fuel Line Replacement” procedure in this chapter.	

3. Fuel Injector Leak Check

NOTICE: Complete this procedure in the cockpit to examine an installed leaky fuel injector.

- A. Disconnect the induction system at the fuel injector inlet to monitor the impact tubes.
- B. Put the throttle in the FULL FORWARD position.
- C. Put the mixture control in the FULL RICH position.
- D. Put a cap on the fuel line to the fuel manifold.
- E. Turn ON the fuel boost pump.
- F. If fuel flows out of the impact tubes, the fuel injector has an internal leak and must be replaced with a serviceable unit.

Fuel System Inspection Checklist

Engine Model:	Engine Serial Number:	Date of Inspection:	Inspector:
Inspection Item	Fuel Line or Injection Nozzle	Findings	Corrective Action Taken
Examine the fuel pump for secure attachment and damage. Replace a damaged or malfunctioning fuel pump per the "Fuel Pump Replacement" procedure in this chapter. Tighten any loose fasteners.	N/A		
Examine the fuel injectors for damage, leaks, and loose fittings or connections. Tighten any loose fitting or connection.* Replace a damaged fuel injector per the "Fuel Injector Replacement" procedure in this chapter.	1		
	2		
	3		
	4		
Examine fuel line fittings for damage or leaks. Unless otherwise stated, make sure all fuel line fittings and connections are secure and correctly torqued.* If tightening does not correct a fuel leak, replace the fitting.	1		
	2		
	3		
	4		
* Per the Standard Torque Tables in the latest revision of the <i>Service Table of Limits - SSP-1776</i> .			

Fuel System Inspection Checklist (Cont.)

Inspection Item	Fuel Line or Injection Nozzle	Findings	Corrective Action Taken
<p>Examine each fuel line for damage, leaks, nicks, crimps, kinks, sharp bends, stains (from fuel leaks), cracks, brittleness, chafing, and looseness. Replace (do not try to repair) a worn, damaged, leaky, chafed, brittle, crimped, kinked, bent, or loose fuel line.</p> <p>Make sure no fuel lines touch the engine or aircraft baffle hardware. There must be a minimum clearance of 3/16 in. (4.76 mm) between a fuel line and any engine or aircraft surface. In general, make sure fuel lines do not touch heat sources.</p>	1		
	2		
	3		
	4		
<p>Make sure the mixture control and throttle linkage have full travel, freedom of movement.</p> <p>Correct the mixture control and throttle linkage limited travel or restricted movement per the aircraft manufacturer's instructions.</p>	N/A		
<p>Lubricate the linkage per the aircraft manufacturer's instruction.</p>	N/A		
<p>Make sure each fuel line is held in place securely using clamps with cushions to prevent fuel line movement due to vibration. <u>If a fuel line had been in service and clamps were not installed, replace the fuel line with a new fuel line.</u></p> <p>Make sure clamps are securely attached. If the clamps are loose, replace the fuel line. Install new clamps that attach the line securely.</p> <p>On engines that use metal clamps with no cushion, install a fuel line sleeve at each of those clamping locations.</p>	1		
	2		
	3		
	4		

Fuel System Inspection Checklist (Cont.)

Inspection Item	Fuel Line or Injection Nozzle	Findings	Corrective Action Taken
Examine the cushion on clamps for deterioration. If cushions are deteriorated or missing, replace the fuel line and the clamp with a new clamp with the cushion intact.	1		
	2		
	3		
	4		
Examine solder joints at the end of each fuel line for cracks. Replace the fuel line if a crack is found at a solder joint.	1		
	2		
	3		
	4		
Operate the engine and look for fuel leaks. Identify and correct the cause of any fuel leak or malfunction. Operate the engine again to make sure it is operating correctly and there is no leak anywhere.	N/A		
Tighten any loose fasteners, fittings, or connections.*	N/A		
* Per the Standard Torque Tables in the latest revision of the <i>Service Table of Limits - SSP-1776</i> .			

NOTICE: Review any applicable warranty information relative to replacement of a fuel component as per the latest revision of Service Letters L221 and L253.

4. Fuel Line Replacement

⚠ WARNING: DO NOT SMOKE OR HAVE AN OPEN FIRE/FLAME OR USE ANY DEVICES THAT CAN MAKE SPARKS DURING THIS REPLACEMENT PROCEDURE. FLAMES OR SPARKS CAN CAUSE FUEL IGNITION WHICH CAN CAUSE BURNS, SERIOUS INJURY, OR DEATH.

NOTICE: If this fuel line replacement procedure is completed with the engine installed in the airframe, refer to the airframe manufacturer's instructions for shutting off the fuel and grounding the aircraft.

A. Fuel Line Removal

- (1) Put a fuel collection container under the fuel line at each fitting connection.
- (2) Make a sketch to identify clamps that attach to brackets for reference on assembly.
- (3) Remove and discard the P and L clamps (Figures 4 and 5) from the fuel line.

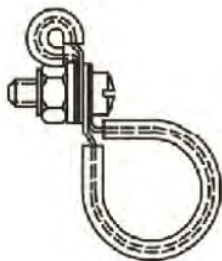


Figure 4
P-Clamp

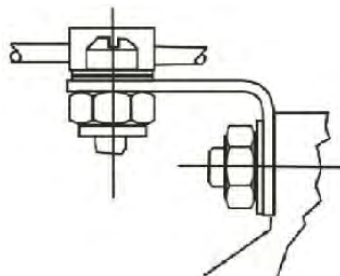


Figure 5
L-Shape Clamp

- (4) Disconnect the fuel line from the fitting on each end.
- (5) Discard the fuel line. (Keep the fuel fittings if they are not part of the fuel line.)
- (6) Remove the fuel collection container and dispose of the fuel in accordance with environmental regulations.

NOTICE: If no clamps were attached to the fuel line, replace the fuel line.

B. Fuel Line Installation

⚠ WARNING: DO NOT ROUTE FUEL LINES CLOSE TO HEAT SOURCES. HEAT CAN DAMAGE THE FUEL LINE AND CAUSE A FUEL LEAK WHICH COULD LEAD TO CATASTROPHIC ENGINE FAILURE.

NOTICE: Refer to the latest revision of Service Instruction No. 1301 for superseded fuel line part numbers.

- (1) Do not let the fuel line touch the engine or aircraft baffle hardware.
- (2) Make sure there is a minimum clearance of 3/16 in. (4.76 mm) between a fuel line and any engine or aircraft surface.
- (3) Make sure the fuel line is not crimped or kinked, there are no cracks at solder joints, and the fuel line is in compliance with Figure 3 for the minimum acceptable dimension for a bend in the fuel line.

NOTICE: If installing a new fuel line where fittings were not attached as part of the fuel line assembly, the fitting can be re-installed if the threads are not damaged.

Some fuel line configurations can either use short or long fuel injector lines. Figure 6 shows short fuel injector lines and long fuel injector lines for an IO-390-C1A6 engine model.

- (4) Connect the fuel line to the fuel fitting on each end.

- (5) Torque each fuel line fitting in accordance with the Standard Torque Tables in the latest revision of the *Service Table of Limits - SSP-1776*.

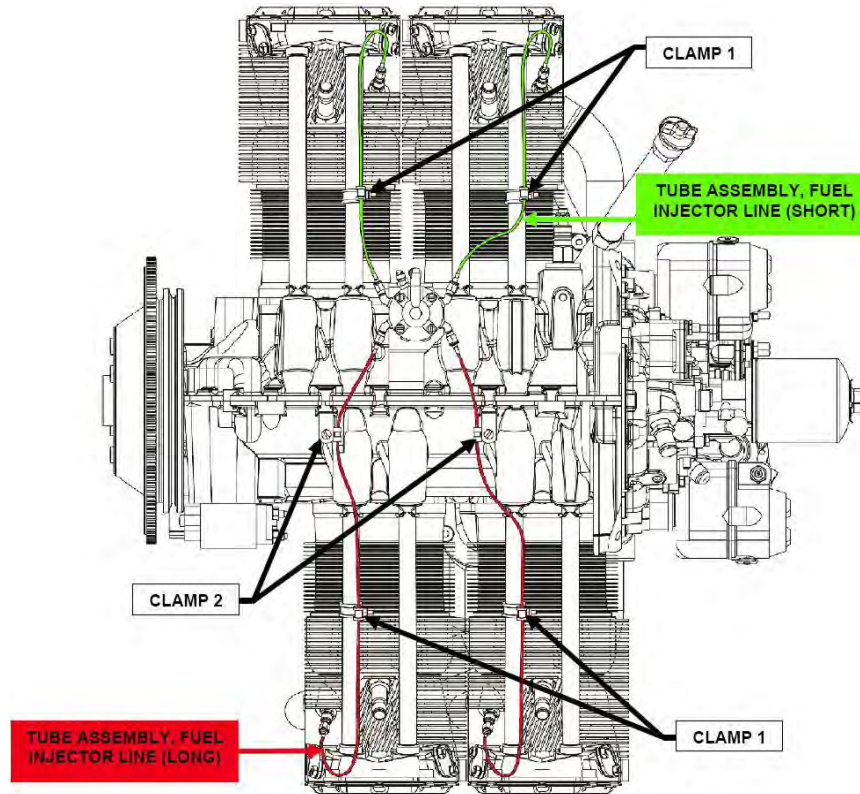


Figure 6
Fuel Injector Lines

- (6) Make sure that the fuel lines are securely held in place, attached to the engine (to dampen vibration during flight) with the necessary serviceable cushioned clamps and hardware. Install clamps on the fuel line as per the following guidelines:
- Make sure each serviceable clamp securely supports the fuel line to prevent fuel line movement due to vibration, friction, or motion frequencies during flight. **Do NOT use plastic tie straps as clamps.**
 - Install serviceable clamps (preferably with cushions) on the fuel line. Make sure the cushion is not missing and is intact, and completely covers the fuel line diameter. If cushions are deteriorated or missing, replace the clamp with a new clamp with the cushion intact.
 - Refer to Figures 4 and 5 which show how the fasteners are to be installed on P-clamps and L-shaped clamps.
 - Make sure the clamps are securely attached to support the fuel line and to prevent movement from vibration or motion frequencies.
 - On engines that used metal clamps with no cushion, use the P/N LW-12598 fuel line sleeve at each of those clamping locations. (Do not use the fuel line sleeve with the serviceable cushioned clamps.)
 - Torque the fuel line union nut (Figure 7) between 35 to 50 in.-lb. (4 to 6 Nm).

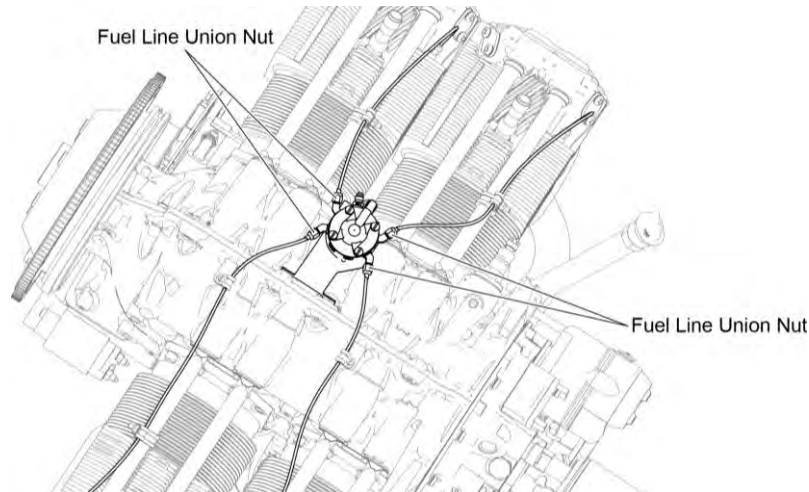


Figure 7
Fuel Line Union Nuts

⚠ CAUTION: TO ENSURE CORRECT ENGINE OPERATION AND FLIGHT SAFETY, THERE MUST NOT BE ANY FUEL LEAK AND ALL FUEL LINES MUST BE SECURED WITH CLAMPS. IDENTIFY AND CORRECT THE CAUSE OF ANY FUEL LEAK.

- (7) During the “Operational Ground Check” in Chapter 72-00 (which is to be done after all maintenance is complete), look for fuel leaks at the fuel lines and connections during engine operation. Identify and correct the cause of any fuel leak. There must not be any fuel leak when the engine is returned to service.

5. Fuel Injector Replacement

⚠ WARNING: DO NOT SMOKE OR HAVE AN OPEN FIRE FLAME OR USE ANY DEVICE THAT CAN MAKE SPARKS. FLAMES OR SPARKS CAN CAUSE FUEL IGNITION WHICH CAN CAUSE SERIOUS BURNS, INJURY OR DEATH.

NOTICE: If this fuel injector replacement procedure is completed with the engine installed in the airframe, refer to the airframe manufacturer’s instructions for shutting off the fuel and grounding the aircraft.

NOTICE: The fuel injector is not repairable. If damaged, the fuel injector must be replaced.

A. Fuel Injector Removal

- (1) Put a fuel collection container under the fuel injector (Figure 8).
- (2) Apply an identification label to each fuel line and disconnect the fuel lines attached to the fuel injector.
- (3) Let fuel drain out of the fuel injector and fuel lines into the fuel collection container.
- (4) Hold the fuel injector and remove the four nuts, lock washers, and washers from the fuel injector. Discard the lock washers.
- (5) Remove the fuel injector and its gasket. Discard the gasket.
- (6) Remove the fuel collection container.

B. Fuel Injector Installation

- (1) Align the fuel injector on the engine with a new gasket (Figure 8).

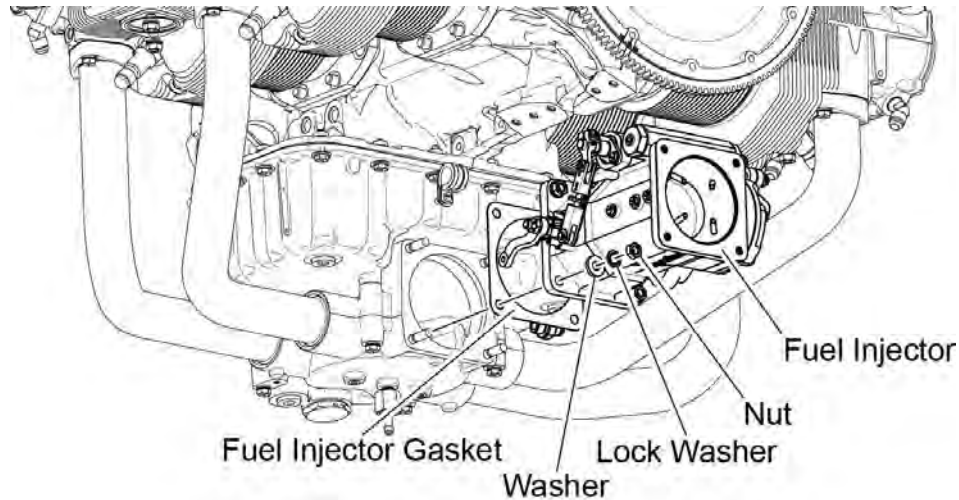


Figure 8
Fuel Injector

- (2) Install four nuts, each with a washer and a new lock washer hand tight. Refer to Figure 9 for the torque sequence for the two different size nuts that can be used:

For 1/4-20 size nuts:

- (a) Torque the nuts in crisscross pattern (Figure 9) to an initial torque of 48 in.-lb. (5 Nm).
- (b) Torque the four nuts again in the same crisscross pattern to a final maximum torque of 96 in.-lb. (11 Nm).

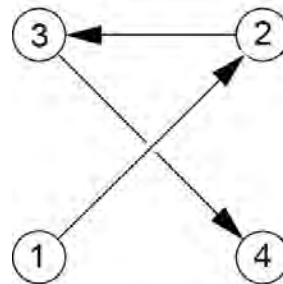


Figure 9
Crisscross Pattern of
Nut Torquing

For 5/16-18 size nuts:

- (a) Torque the nuts in crisscross pattern (Figure 9) to an initial torque of 90 in.-lb. (10 Nm).
- (b) Torque the four nuts again in the same crisscross pattern to a final maximum torque of 204 in.-lb. (23 Nm).

- (3) During the “Operational Ground Check” in Chapter 72-00 (which is to be done after all maintenance is complete), look for fuel leaks at the fuel lines and connections during engine operation. Identify and correct the cause of any fuel leak. There must not be any fuel leaks when the engine is returned to service.

6. Injection Nozzle Replacement

⚠ WARNING: DO NOT SMOKE OR HAVE AN OPEN FIRE FLAME OR USE ANY DEVICE THAT CAN MAKE SPARKS. FLAMES OR SPARKS CAN CAUSE FUEL IGNITION WHICH CAN CAUSE SERIOUS BURNS, INJURY OR DEATH.

NOTICE: If this injection nozzle replacement procedure is completed with the engine installed in the airframe, refer to the airframe manufacturer’s instructions for shutting off the fuel and grounding the aircraft.

A. Injection Nozzle Removal

- (1) Disconnect the fuel line from the injection nozzle (Figure 10).
- (2) Remove the injection nozzle from the engine cylinder.

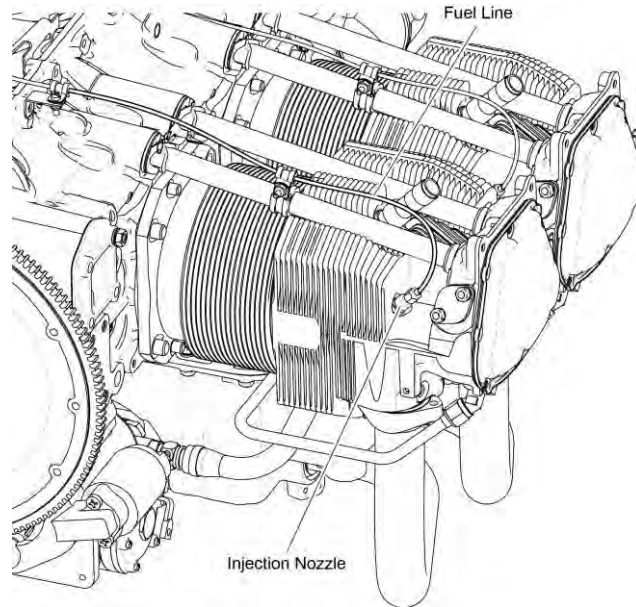


Figure 10
Injection Nozzle

B. Injection Nozzle Cleaning

⚠ CAUTION: NEVER USE A SHARP TOOL SUCH AS A WIRE OR PIN TO CLEAN OUT AN INJECTION NOZZLE. DAMAGE TO THE INLET AND OUTLET FUEL RESTRICTORS COULD OCCUR WHICH WOULD CHANGE THE FUEL FLOW.

Complete the “Injection Nozzle Cleaning” procedure in Chapter 5-30.

NOTICE: Injection nozzles are not repairable.

C. Injection Nozzle Installation

- (1) (Optional) Complete the “Injection Nozzle Fuel Flow Check” in this chapter.
- (2) Lightly lubricate the injection nozzle threads with engine oil mixture.
- (3) Install the injection nozzle (Figure 10) on the engine cylinder.
- (4) Torque the injection nozzle to 60 in.-lb. (7 Nm). Continue to torque the injection nozzle until the letter or number stamped on the nozzle points downward.
- (5) Connect the fuel line to the injection nozzle.
- (6) During the “Operational Ground Check” in Chapter 72-00 (which is to be done after all maintenance is complete), look for fuel leaks at the fuel lines and connections during engine operation. Identify and correct the cause of any fuel leak. There must not be any fuel leaks when the engine is returned to service.

7. Injection Nozzle Fuel Flow Check

- A. Label each fuel injector and fuel line according to cylinder number.
- B. Disconnect the fuel line from the injection nozzle (Figure 10).
- C. Remove the injection nozzle from the engine cylinder.
- D. Connect the fuel lines to the injection nozzles according to the cylinder number.
- E. Put the injection nozzles into four clear containers of equal size on a flat surface.
- F. Turn the boost pump on and move the throttle and mixture control full forward.
- G. Examine the fuel flow from each injection nozzle to make sure the fuel stream is not scattered (which is an indication of blockage in the injection nozzle) identified as “Incorrect” in Figure 11.

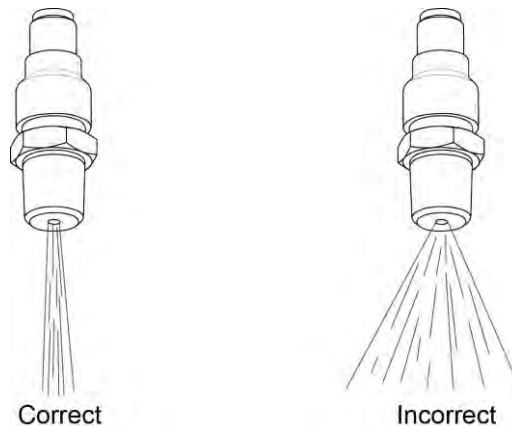


Figure 11
Injection Nozzle Stream

- H. Let approximately 4 to 6 oz. (120 to 180 ml) of fuel to flow into each container. Close the throttle and mixture control and turn off the boost pump.
- I. Measure the level of the fuel. All containers must have the same amount of fuel. A container with less fuel is an indication of a fuel flow restriction.

NOTICE: If the fuel flow is incorrect, disconnect the injection nozzle and clean the nozzle according to the “Injection Nozzle Cleaning” procedure in Chapter 05-30. Repeat the fuel flow check. If cleaning does not correct the scattered stream, replace the injection nozzle. Fuel injection nozzles are not repairable.

- J. Disconnect the fuel lines from the injection nozzles.
 - K. Install acceptable injection nozzles in the cylinders and connect the fuel lines. Refer to the latest revision of the *Service Table of Limits - SSP-1776* for torque values.
8. Fuel Manifold Replacement

⚠ WARNING: DO NOT SMOKE OR HAVE AN OPEN FIRE FLAME OR USE ANY DEVICE THAT CAN MAKE SPARKS. FLAMES OR SPARKS CAN CAUSE FUEL IGNITION WHICH CAN CAUSE SERIOUS BURNS, INJURY OR DEATH.

NOTICE: If this fuel manifold replacement procedure is completed with the engine installed in the airframe, refer to the airframe manufacturer’s instructions for shutting off the fuel and grounding the aircraft.

A. Fuel Manifold Removal

- (1) Put a fuel collection container under the fuel manifold.
- (2) Identify the fuel line ports on the fuel manifold (Figure 1).
- (3) Apply a label and disconnect all fuel lines attached to the fuel manifold.
- (4) Let fuel drain out of the fuel manifold and fuel lines into the collection container.
- (5) Remove the safety wire/cable from hardware fasteners on the brackets on the fuel manifold (Figures 12A thru 12D).
- (6) Remove the bolts, screws, lock washers, bracket, and the fuel manifold from the fuel injector (Figure 1). Discard the lock washers.
- (7) Remove the fuel collection container.

B. Fuel Manifold Installation

NOTICE: There are different fuel manifold configurations. Figures 12A thru 12D are examples of the fuel manifold configurations. Your configuration can be different. Be sure to safety wire the hardware fasteners on the fuel manifold and bracket.

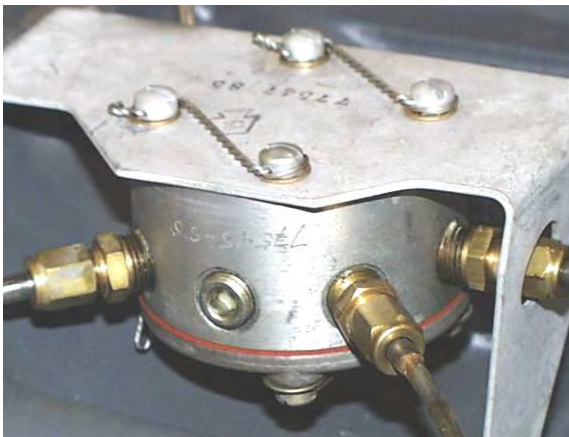


Figure 12A
Safety Wire the Screws



Figure 12B
Safety Wire the Screws



Figure 12C
Safety Wire the Screws



Figure 12D
Safety Wire the Screws

- (1) Install the fuel manifold and the bracket (Figure 1) on the fuel injector with the hardware fasteners. Torque the bolts and screws on the bracket to 25 to 30 in.-lbs (2 to 3 Nm).
- (2) Safety wire/cable the bolts and screws on the bracket as shown in Figures 12A to 12D.
- (3) Attach all fuel fittings with fuel line to the corresponding identified ports on the fuel manifold.
- (4) Torque the fuel line fittings in accordance with the latest revision of the ***Service Table of Limits - SSP-1776***.
- (5) During the “Operational Ground Check” in Chapter 72-00 (which is to be done after all maintenance is complete), look for fuel leaks at the fuel lines and connections during engine operation. Identify and correct the cause of any fuel leak. There must not be any fuel leak when the engine is returned to service.

9. Fuel Pump Replacement

⚠ WARNING: DO NOT SMOKE OR HAVE AN OPEN FIRE FLAME OR USE ANY DEVICE THAT CAN MAKE SPARKS. FLAMES OR SPARKS CAN CAUSE FUEL IGNITION WHICH CAN CAUSE SERIOUS BURNS, INJURY OR DEATH.

NOTICE: If this fuel pump replacement procedure is completed with the engine installed in the airframe, refer to the airframe manufacturer’s instructions for shutting off the fuel and grounding the aircraft.

The fuel pump is not repairable. If the fuel pump is damaged or non-operational, replace the fuel pump with a serviceable unit.

A. Fuel Pump Removal

- (1) Put a fuel collection container under the fuel line connections at the AC-type fuel pump (Figure 13).
- (2) Apply a label and disconnect the fuel lines to the fuel pump.
- (3) Remove the two screws and washers from the fuel pump.
- (4) Remove the fuel pump and gasket from the accessory housing. Discard the gasket.
- (5) Remove the fuel collection container.

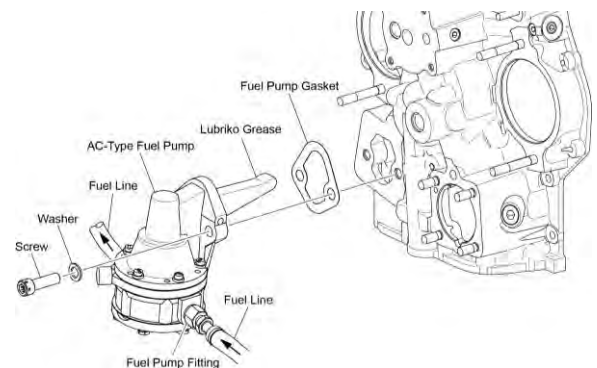


Figure 13
AC-Type Fuel Pump

B. Fuel Pump Installation

- (1) Turn the crankshaft to move the fuel pump plunger to the highest position.
 - (2) Apply Lubriko M-6 grease to the shaft of the AC-type fuel pump.
 - (3) Apply Loctite[®] 564 or equivalent to the fuel pump screws.
- NOTICE:** If fitting P/N 74070 is necessary for the fuel line, install this fitting on the fuel pump prior to installing the fuel pump on the engine.
- (4) Install the fuel pump with a new gasket on the accessory housing as shown in Figure 13 with the two washers and two screws.

- (5) Torque the screws to 225 to 250 in.-lbs. (25 to 28 Nm).
- (6) Connect the fuel lines to the fuel pump. Torque the fuel fitting to 23 to 24 ft.-lb. (31 to 35 Nm). Make sure that the fuel lines are securely connected.
- (7) During the “Operational Ground Check” in Chapter 72-00 (which is to be done after all maintenance is complete), look for fuel leaks at the fuel lines and connections during engine operation. Identify and correct the cause of any fuel leak. There must not be any fuel leak when the engine is returned to service.

74-20 - IGNITION SYSTEM - MAINTENANCE

⚠ WARNING: FAILURE TO MAINTAIN THE SPARK PLUGS AND IGNITION LEADS CAN CAUSE ENGINE DAMAGE OR FAILURE.

NOTICE: The ignition leads are an all-weather, shielded wire constructed with over braid.

1. Spark Plugs

Two long reach spark plugs (Figure 1) are installed on each cylinder head (Figure 2) of the engine for a total of eight spark plugs per engine.

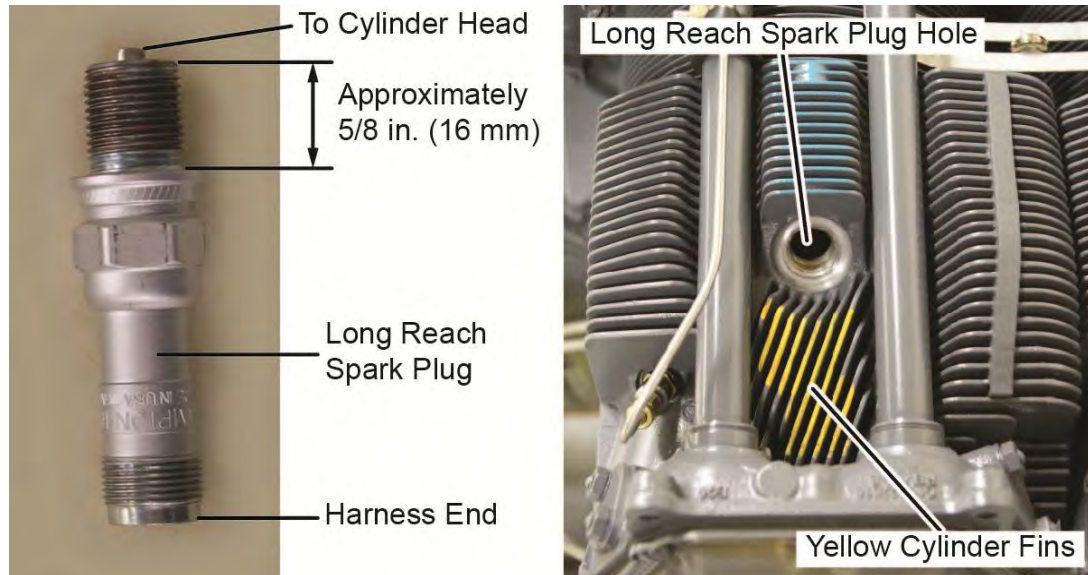


Figure 1
Long Reach Spark Plug & Location

NOTICE: Typically engines with long reach spark plugs are identified by yellow paint on the cylinder fins between the spark plug hole and the rocker covers where shown in Figure 1.

Refer to the latest revision of Service Instruction No. SI-1042 to identify the correct spark plug approved for use in these engines.

2. Spark Plug Removal

- A. Make sure that the power is disconnected from the engine.
- B. Hold the ferrule and loosen the spark plug nut and disconnect it from the ignition lead.

⚠ CAUTION: HOLD FERRULES WHILE LOOSENING THE SPARK PLUG COUPLING NUT TO PREVENT TWISTING THE CONDUIT OR CABLE.

- E. Use the applicable sized socket on top of the spark plug and turn the socket to remove the spark plug from the engine cylinder head (Figure 2).
- F. Identify by tag or label each spark plug as it is removed, according to cylinder number and top or bottom position.
- G. Remove and discard the gasket from the spark plug (Figure 2).

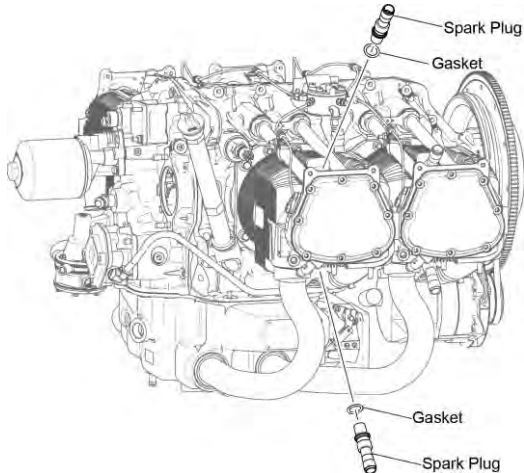


Figure 2
Spark Plugs



Figure 3
Ignition Lead

3. Ignition Harness Inspection

NOTICE: The ignition leads are an all-weather, shielded wire constructed with over braid.

- A. Examine spark plug ignition leads (Figure 3) and spark plug ceramics for corrosion and deposits.
- B. Examine each ignition lead for chafing, insulation breakdown, frayed wiring, deterioration, heat damage, wear, and cracking. Replace the harness if any lead shows evidence of chafing, cracks, or wear, frayed wiring, or damage.
- C. Examine the ignition lead connections. Make sure the ignition lead connections are secure.
- D. Make sure the ignition lead mounting clamps are tight.

4. Spark Plug Inspection

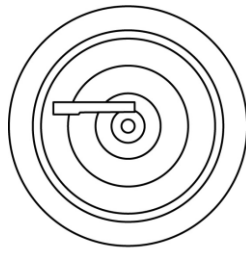
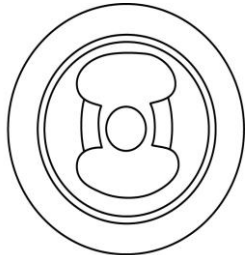
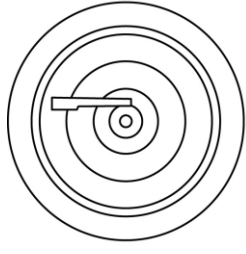
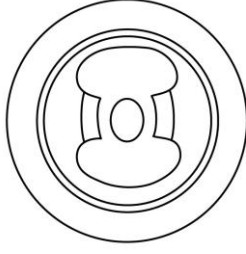
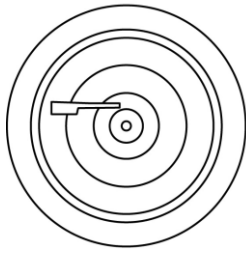
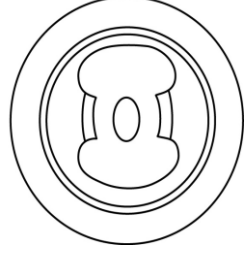
NOTICE: Corrosion and deposits are evidence of leaking spark plugs or incorrect cleaning of the spark plugs or connector ends.

- A. Remove the spark plug connector nuts.
- B. Examine each spark plug for chafing, corrosion, wear, and cracking during every inspection. Replace any worn, cracked or corroded spark plug with a new spark plug.

NOTICE: The general guidelines in Table 1 identify acceptable and unacceptable spark plugs. The figures in Table 1 show the condition of the fine wire ground and center electrodes as well as the level of wear indication and condition of the spark plug. Refer to your spark plug manufacturer's manual for specific instructions.

- C. To be acceptable, the spark plug must not have any of the following defects:
 - (1) Fine wire plugs with loose center or ground electrodes
 - (2) Electrodes that show signs of metal or impact damage
 - (3) Massive electrode plugs with copper run-out of the center electrode
 - (4) Ceramic core nose with a cracked or crazed rough surface
- D. Measure the spark plug gap to make sure it is at the correct tolerance per the latest revision of Service Instruction No. SI-1042. Reset the spark plug gap if it is not correct. Refer to the "Spark Plug Gap Setting" procedure in this chapter.

**Table 1
General Spark Plug Wear/Replacement Guidelines**

Spark Plug	Findings	Condition of Fine Wire Ground Electrode on Spark Plug	Condition of Center Electrode on Spark plug	What to do
Acceptable Spark Plugs	Insulator tip gray, tan or light brown No ash deposits Electrodes intact, not burnt or eroded			Clean, set the spark plug gap and install the spark plug per applicable sections in this chapter and in Chapter 05-30.
Partially Worn Spark Plugs	Ash deposits Electrode burnt and/or eroded to less than half of the original thickness More voltage has been necessary to fire the spark plugs			Discard the spark plug and replace with a serviceable spark plug.
Worn Spark Plugs	Erosion of center and ground electrode Extensive necking of the fine wire ground electrode			Look for excessive heat sources. Discard the spark plug and replace with a serviceable spark plug.

5. Spark Plug Fouling

- A. Lead deposits can collect on the spark plug electrodes when the engine operates at lower-than-specified temperatures with fuel-rich mixtures (fuel-rich mixtures do not enable vaporization of lead in aviation gas). These deposits can cause misfiring.
- B. Recommendations to prevent spark plug fouling:
 - If the engine is approved for use with unleaded fuel per the latest revision of Service Instruction SI-1070, use unleaded fuel after purging the fuel system.
 - Rotate top and bottom spark plugs every 100 operating hours or annually – refer to the “Spark Plug Rotation” procedure in this chapter.
 - Operate the engine between 1000 and 1200 rpm after engine start and during warm-up. (At these speeds the spark plug core temperatures are sufficiently hot to activate the lead scavenging agents to prevent lead deposits on the spark plugs.)
 - Operate the engine at the specified operating temperature to prevent low temperature operation.

- Use oil cooler baffles to keep the oil temperature from decreasing during winter flight.
- Do not stop the engine immediately after landing to prevent rapid engine cooling.
- Before engine shutdown, operate the engine between 1000 and 1200 rpm until operating temperatures are stable. Then increase engine speed to 1800 rpm for 15 to 20 seconds. Then decrease engine speed between 1000 and 1200 rpm before engine shutdown.

6. Spark Plug Port Seal Inspection

NOTICE: This inspection is usually done to complete the check of the Heli-coil[®] spark plug insert in the cylinder head.

- A. Apply a soap solution to the seating area of the cylinder head.
- B. Look for bubbles. If bubbles are seen, replace the Heli-coils[®]. Replace all loose or damaged spark plug Heli-coil[®] inserts with oversize inserts per instructions in Chapter 72-30.
- C. Examine the spark plugs (if not already done). Refer to the section “Spark Plug Inspection” procedure in this chapter.
- D. Examine the surface of the cylinder (covered with soap) for cracks. Refer to the “Visual Cylinder Inspection Procedure” in Chapter 72-30.

7. Spark Plug Cleaning

Complete the “Spark Plug Cleaning” procedure in Chapter 05-30.

8. Spark Plug Gap Setting

- A. Refer to the latest revision of Service Instruction No. 1042 to identify the correct spark plug for this engine.
- B. Make sure the “Spark Plug Cleaning” procedure in Chapter 05-30 was completed and that the inside of the spark plug barrel is clean and dry and does not have any residue from cleaning.
- C. Before spark plug installation, set the spark plug gap in accordance with the latest revision of Service Instruction No. SI-1042.
- D. Reset and test the spark plugs in accordance with the spark plug manufacturer’s instructions.

9. Spark Plug Rotation

NOTICE: As part of routine service, rotate spark plugs in different locations per Table 2 every 100 hours of engine operation or annually (whichever occurs first) or when there is evidence of spark plug fouling.

- A. Remove all of the spark plugs. Refer to the “Spark Plug Removal” procedure in this chapter.
- B. Examine each spark plug and ignition lead. Refer to the “Spark Plug Inspection” and “Ignition Harness Inspection” procedures in this chapter.
- C. Complete the “Spark Plug Cleaning” procedure in Chapter 05-30.

⚠ CAUTION: USE CARE TO PREVENT THE COPPER-BASED ANTI-SEIZE FROM GETTING ON THE SPARK PLUG ELECTRODE OR IN THE COMBUSTION CHAMBER.

DO NOT APPLY A GRAPHITE-BASED COMPOUND TO THE SPARK PLUG THREADS.

- D. Apply C5-A Copper-Based Anti-Seize (Figure 4) or engine oil to the threads of each spark plug (starting two full threads from the electrode.)
- E. Rotate acceptable spark plugs per the rotation scheme in Table 2.
- F. Refer to the “Spark Plug Installation” procedure in this chapter.



Figure 4
Copper-Based Anti-Seize
Applied to Spark Plug Threads

Table 2
Spark Plug Rotation Scheme

#1 Top	with	#4 Bottom
#2 Top	with	#3 Bottom
#3 Top	with	#2 Bottom
#4 Top	with	#1 Bottom

10. Spark Plug Installation

- A. If not already done, apply C5-A Copper-Based Anti-Seize (Figure 4) or engine oil to the threads of each spark plug (starting two full threads from the electrode.)

⚠ CAUTION: FAILURE TO INSTALL A NEW SPARK PLUG GASKET ANY TIME A SPARK PLUG IS INSTALLED CAN RESULT IN INCOMPLETE SEALING OF THE COMBUSTION CHAMBER, LOSS OF SPARK PLUG HEAT TRANSFER, SPARK PLUG OVERHEATING, POSSIBLE REIGNITION/DETONATION, AND INTERNAL ENGINE DAMAGE.
 NEVER INSTALL A SPARK PLUG THAT HAS BEEN DROPPED.

- B. Install a new spark plug gasket (Figure 2) with the spark plug. A new gasket must be installed whether the spark plug is new or is acceptable and being reused.
- C. Install the spark plug in the cylinder top and bottom (Figure 2).
- D. Torque the spark plug per instructions in the latest revision of Service Instruction No. SI-1042.
- E. Connect the spark plug to the applicable ignition lead per the “Ignition Harness Installation” procedure in this chapter.
- F. Torque the spark plug lead nut per instructions in the latest revision of Service Instruction No. SI-1042.

11. Ignition Harness Removal

- A. Remove the ignition harness (Figure 5) from the engine harness.
 - (1) Disconnect the clamps that attach the ignition harness to the engine.
 - (2) Remove the screws which attach the harness cap to the magneto.
 - (3) Disconnect the ignition leads from the spark plugs.
 - (4) Remove the ignition harness.

NOTICE: The left ignition harness is marked "left." The right ignition harness is marked "right."

12. Ignition Harness Inspection

- A. Examine the ignition harness (Figure 5) for broken, frayed, chafed, abraded, degraded, overheated or damaged wiring and connections. Replace the ignition harness if a wire is broken, frayed, chafed, abraded, degraded, overheated, or damaged. Wiring degradation includes:
 - (1) Degraded wire repairs or slices
 - (2) Heat damaged or burnt wire
 - (3) Vibration damage or chafing
 - (4) Cracked insulation
 - (5) Arcing
 - (6) Insulation delamination
- B. Examine the ignition harness, cables, and clamps for wear or damage. Replace any worn or damaged cable or clamp per the aircraft manufacturer's instructions.
- C. Figure 6 shows an example of ignition harness routing. Your harness routing configuration could be different due to engine installation arrangement.

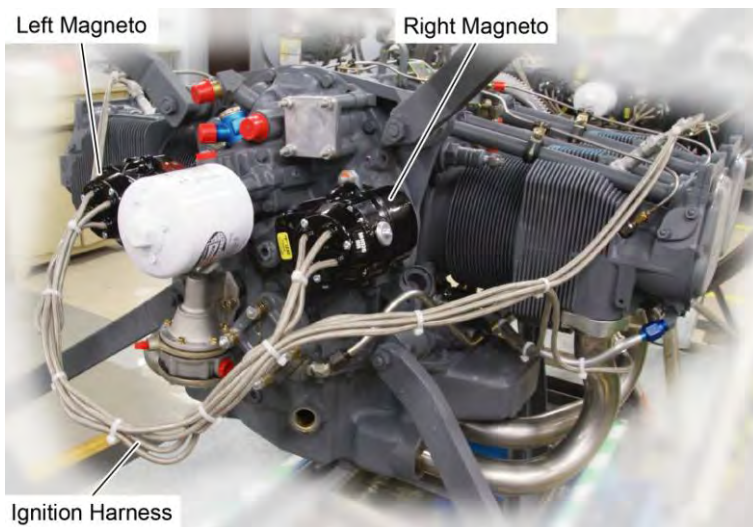


Figure 5
Ignition Harness

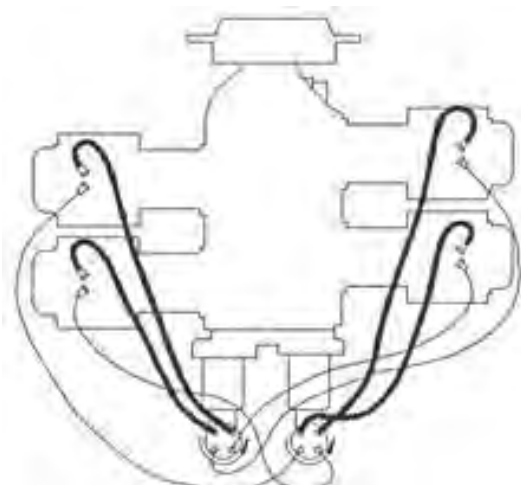


Figure 6
Example of Ignition Harness Routing

13. Ignition Harness Installation

- A. Attach the left ignition harness to the left magneto (Figure 5).
- B. Attach the right ignition harness to the right magneto.

NOTICE: Each spark plug ignition harness nut is marked with a letter and number identifying the spark plug position on each respective cylinder. A spark plug nut marked "T1" identifies the top spark plug on cylinder #1 to which that ignition lead is to be connected. A spark plug nut marked "B4" identifies the bottom spark plug on cylinder #4 to which that ignition lead is to be connected.

C. Route and connect the ignition leads to the spark plugs:

- (1) Route the ignition leads to the appropriate spark plug position as indicated by the alphanumeric markings on each spark plug nut.
- (2) When the spark plug nut thread makes contact with the spark plug threads, push the ferrule against the spark plug while turning the spark plug nut clockwise.
- (3) Continue turning the spark plug nut until it seats and is finger-tight.

NOTICE: In the next step, a hex ferrule will protrude above the spark plug mounting nut. Hold this hex ferrule with a 7/16 in. wrench while tightening the spark plug nuts to prevent twisting of the ignition lead.

- (4) Torque the spark plug lead nut per instructions in the latest revision of Service Instruction No. SI-1042.
- D. Position the ignition harness (Figures 5 and 6) to prevent chafing by baffles or engine parts. There must not be any kinks or sharp bends in the ignition lead wire routing.

This page intentionally left blank.

74-30 - IGNITION SYSTEM - MAGNETO MAINTENANCE

1. Magneto Inspection

Examine the magneto in accordance with the magneto manufacturer's instructions after every 500 hours of engine operation.

2. Magneto-to-Engine Timing Check

A. Disconnect the ignition leads from all spark plugs.

B. Remove the nut and lock washer from the condenser terminal on the magneto. Disconnect the P-Leads from the magneto. Discard the lock washer.

C. Remove one of the spark plugs from Cylinder No. 1 per the "Spark Plug Removal" procedure in Chapter 74-20.

NOTICE: If the engine is equipped with impulse-coupled magnetos, turn the crankshaft in the direction of normal rotation until Cylinder No. 1 is at Top Dead Center (TDC). Continue to turn the crankshaft, in the direction of normal rotation, until the impulse couplings in the magnetos have snapped and released. Then, turn the crankshaft in the direction **opposite** normal rotation until Cylinder No. 1 is on the compression stroke, approximately 35° before TDC.

D. Turn the crankshaft in the direction of normal rotation until Cylinder No. 1 is on the compression stroke, approximately 35° before TDC.

E. Put your thumb over the spark plug hole and turn the crankshaft in the direction of normal rotation until there is pushback pressure at the spark plug hole.

NOTICE: Some timing lights operate in the reverse manner than identified herein. The light comes on when the contact points open. Refer to your timing light instructions.

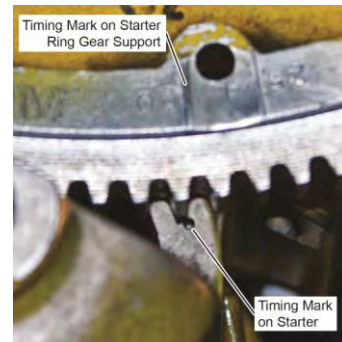
F. Connect the timing light leads to the appropriate magneto condenser terminals and the ground lead to any unpainted portion of the engine.

NOTICE: There are two reference points on the engine to be used when aligning the timing marks on the starter ring gear support:

- When viewing the starter ring gear support from the crankcase side, the reference point is the crankcase parting flange (Figure 1).
- When viewing the starter ring gear support from the propeller side, the reference point is the timing mark on the starter (Figure 2).

**Figure 1**

Timing Marks on the Crankcase Side of the Starter Ring Gear Support Aligned with the Crankcase Parting Flange

**Figure 2**

Timing Marks on the Propeller Side of the Starter Ring Gear Support Aligned with the Timing Mark on the Starter

NOTICE: The advance timing specification in degrees is stamped on the engine data plate.

- G. Turn the crankshaft in the direction of normal rotation until the correct advance timing mark on the starter ring gear support aligns with the reference point on the engine (Figure 1 or 2).
- H. The timing light is to indicate the magneto is firing when the timing mark on the starter ring gear support aligns with the reference point on the engine (Figures 1 or 2) to ensure that the magnetos are correctly timed with the engine.

NOTICE: If there is interference from another engine component or an airframe component that prevents correct adjustment of the magneto, remove the magneto and re-position the drive gear in the accessory housing. Use care not to drop the dampers (if installed) into the engine while repositioning the drive gear.

- I. The magneto position is typically 15° to 30° above horizontal centerline (Figure 3).



Figure 3
Typical Magneto Position

NOTICE: If the magneto-to-engine timing is out of tolerance by more than 5° refer to the magneto manufacturer's instructions for internal adjustment and then complete the "Magneto Adjustment Procedure" in this chapter.

If the magneto-to-engine timing is out of tolerance by less than 5°, complete the "Magneto Adjustment Procedure" in this chapter.

- J. If the magneto-to engine timing is within tolerance or after the "Magneto-to-Engine Timing Adjustment" procedure has been completed:
 - (1) Remove the timing light leads from the magnetos and grounding source.
 - (2) Attach the P-Leads to the condenser terminal of each magneto with the nut and a new lock washer. Torque the nut to 13 to 15 in.-lb (1.5 to 1.7 Nm).
- K. Install ignition harness assemblies on the magnetos. The left magneto harness is labeled "left" and the right magneto harness is labeled "right".
- L. Torque the cap-mounting screws per the magneto manufacturer's instructions.
- M. Install the spark plug in cylinder No. 1 per the "Spark Plug Installation" section in Chapter 74-20.
- N. Enable power to the engine.
- O. Complete the "Operational Ground Check" in Chapter 72-00 of the engine to make sure the magnetos are operating correctly.

3. Magneto Adjustment Procedure

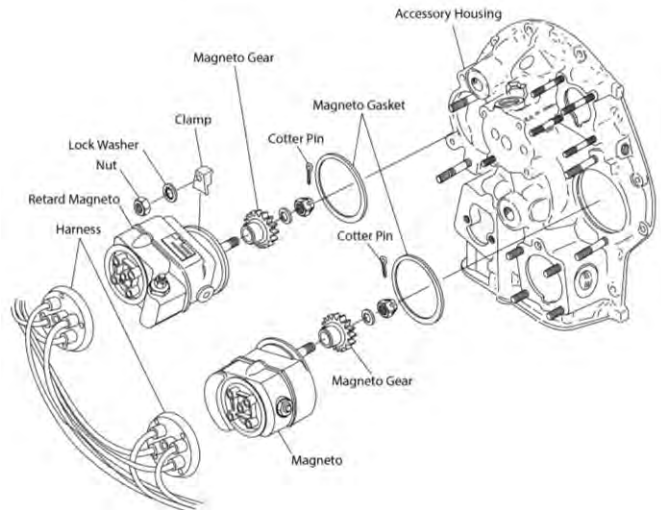
- A. Turn the crankshaft in the direction of normal rotation until the correct advance timing mark on the starter ring gear support aligns with the reference point on the engine (Figure 1 or 2)..
- B. Loosen the hold down nuts on the clamps of the magneto that is not timed with the engine.
- C. Manually and slowly turn the magneto in its mounting flange in the direction opposite its normal rotation until the timing light indicates the magneto is not firing.
- D. Turn the magneto in the direction of normal rotation until the timing light indicates the magneto is firing.
- E. Torque the hold-down nuts on the magneto clamps 48 in.-lb. (5 Nm) increments, alternating between the two nuts until both nuts are torqued to 15 to 18 ft.-lb. (20 to 24 Nm).
- F. Apply torque seal to the torqued hold-down nuts on the magneto clamps.
- G. Complete the previous steps on the other magneto to ensure that both timing lights indicate the magnetos are firing when the timing mark on the starter ring gear support aligns with the reference point on the engine (Figure 1 or 2).
- H. Turn the crankshaft a few degrees in the direction opposite normal rotation. The timing lights should indicate the magnetos are not firing.
- I. Slowly turn the crankshaft in the direction of normal rotation until the correct advance timing mark on the starter ring gear support (Figure 1) aligns with the reference point on the engine (Figure 1 or 2). Both lights on the timing light should indicate the magnetos are firing.
- J. Adjust the magneto-to-engine timing until repeat checks by the “Magneto-to-Engine Timing Check” are within tolerance.

4. Magneto Replacement Procedure

⚠ WARNING: BEFORE THIS PROCEDURE, MAKE SURE ALL POWER IS DISABLED TO THE ENGINE TO PREVENT ELECTRICAL SHOCK AND INJURY.

A. Magneto Removal

- (1) Disconnect the harness (Figure 4) from the magneto to be removed.
- (2) Hold the magneto and remove the two nuts, two lock washers and two clamps from the magneto. Discard the lock washers.
- (3) Remove the magneto.
- (4) Remove and discard the gasket.



**Figure 4
Magnetos**

B. Magneto Installation

NOTICE: This procedure applies to Slick magnetos only. Refer to the manufacturer's instructions for other types of magnetos.

Make sure the correct magneto is installed on the corresponding side of the engine.

A new or serviceable magneto, new magneto gasket, and two new lock washers are necessary to install the magneto. Refer to the applicable parts catalog.

- (1) Apply a light coat of C5-A Copper-Based Anti-Seize compound to the tapered section of the magneto driveshaft (Figure 5).
- (2) Install the magneto magneto gear or impulse coupling (whichever is applicable) on the magneto driveshaft.
- (3) Remove excess anti-seize compound from the magneto driveshaft.
- (4) Install the gear nut on the magneto drive shaft. Torque the gear nut per the magneto manufacturer's instructions.

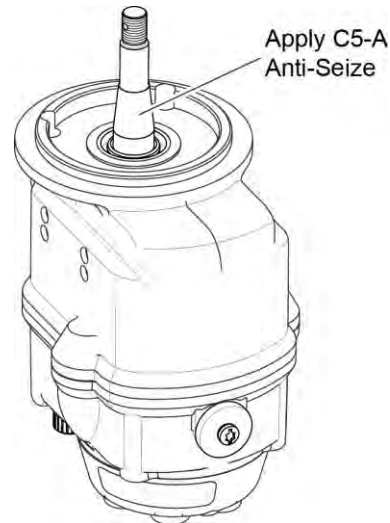


Figure 5
Anti-Seize Application

- (5) Install a new cotter pin through the nut and magneto driveshaft. Bend the top prong on the cotter pin over the stud and bend the bottom prong of the cotter pin down.
- (6) Install a new cotter pin through the stud and castle nut. Bend the top prong on the cotter pin over the stud and bend the bottom prong of the cotter pin down.
- (7) Verify the magneto direction of rotation as per the magneto data plate.
- (8) Install a timing pin (Figure 6) in the hole marked Left or Right on the face of the distributor block based on the magneto rotation requirements.



Figure 6
Timing Pin

- (9) Apply a slight inward pressure to the pin and slowly turn the magneto drive shaft in the direction of normal rotation until the shoulder of the pin seats against the distributor block. When correctly engaged, the timing pin will be inserted 7/8 in. (22 mm) into the distributor block.
- (10) If not already done, turn the crankshaft in the direction of normal rotation until the correct advance timing mark on the starter ring gear support aligns with the reference point on the engine (Figures 1 or 2).
- (11) Apply Lubriko M-6 grease to the mating flange and install a new gasket on the mating flange of the magneto.

- (12) Remove the timing pin and install the magneto on the engine with the clamp, nuts, and new lock washers (Figure 6).
- (13) Torque the two nuts on the magneto clamps to 48 in.-lb. (5 Nm) in increments, alternating between the two nuts until both nuts are torqued to 15 to 18 ft.-lb. (20 to 24 Nm).
- (14) Connect the harness to the magneto.
- (15) Complete the “Magneto-to-Engine Timing Check” in this chapter.

This page intentionally left blank.

78-00 - EXHAUST SYSTEM - INSPECTION

1. Exhaust System Inspection
 - A. Remove any components that interfere with this inspection.
 - B. Examine the exhaust flange to exhaust port connections for a powdery white to light brown or black residue indicating exhaust leakage.
 - C. Replace any leaking gaskets (Figure 1).
- ⚠ CAUTION:** EXHAUST LEAKS CAN CAUSE DAMAGE TO SPARK PLUGS, IGNITION CABLES, AND THE CYLINDER HEAD. EXHAUST GAS LEAKAGE BETWEEN THE EXHAUST FLANGE AND EXHAUST PORT PAD CAN QUICKLY ERODE THE CYLINDER HEAD. IDENTIFY AND CORRECT THE CAUSE OF ANY LEAKS. IF LEAKAGE IS FOUND, IT COULD BE NECESSARY TO OR REPLACE THE CYLINDER PER CHAPTER 72-30.
- D. Tighten any loose gasket flange assemblies in accordance with the torque values in the latest revision of the *Service Table of Limits - SSP-1776*.
 - E. Examine exhaust manifolds for visible damage such as bulging, cracks, dents, residue and overall general condition. Correct deficiencies in accordance with aircraft or exhaust manufacturer's procedures.

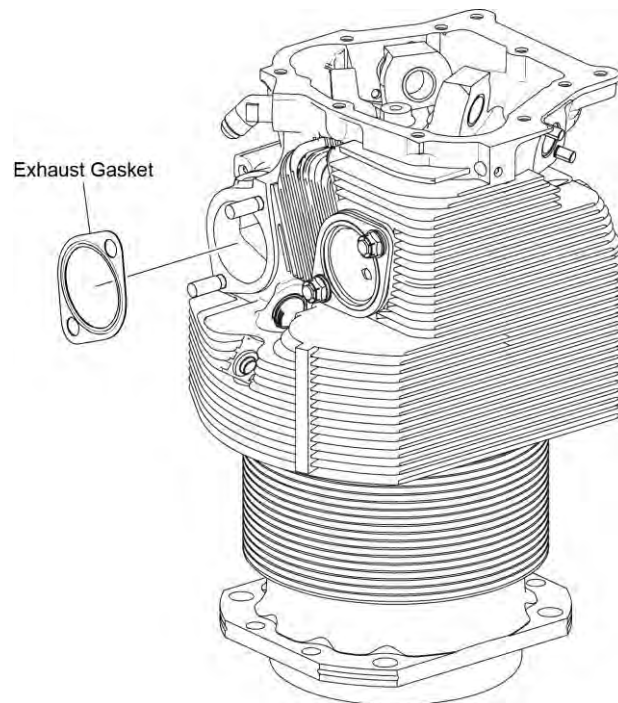


Figure 1
Exhaust Gasket

This page intentionally left blank.

APPENDIX A**Crankcase Stud Replacement**

NOTICE: This procedure does not apply to crankcase thru-studs. Refer to Chapter 72-20 for crankshaft thru-stud removal.

The procedure for replacement of crankcase studs depends on the type of stud and how it was damaged.

1. Replace all crankcase studs that are bent, broken, damaged, loose, rusted, corroded, or cannot be cleaned.
2. To remove and replace a crankcase stud (Figure A-1):

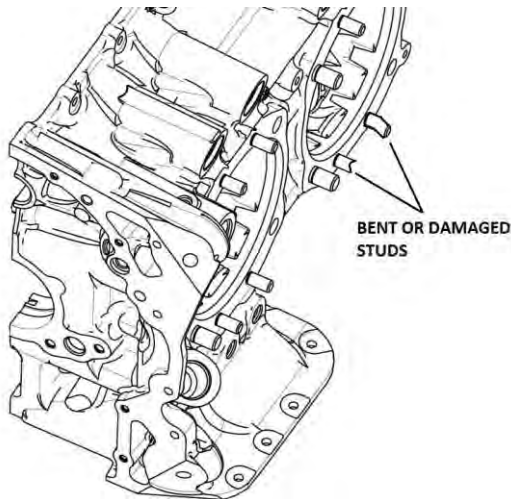


Figure A-1
Damaged Crankcase Stud



Figure A-2
Stud Removal Tool

- A. If the stud has sufficient thread area, use a stud removal tool (Figure A-2). Refer to the tool manufacturer's instructions.
- B. If you cannot use a stud removal tool or if the stud is broken beneath the surface of the crankcase:
 - (1) Drill a small hole in the stud.
 - (2) Use a pilot bushing to guide the drill into the center of the stud
 - (3) Drill again to adjust the size of the hole to the necessary extractor.
 - (4) Remove the stud with the extractor.
- C. After stud removal, examine the size and condition of the threads in the stud holes in the crankcase.
- D. If necessary, replace the regular size studs with oversize studs.
- E. Apply a layer Loctite[®] Food-Grade Anti-Seize or equivalent to the threads on the new stud.
- F. Drive the new stud to the correct depth in the crankcase with an applicable stud driver. Refer to the minimum drive torque in the Special Torque Requirements Tables in Part 1, Section V in the latest revision of the *Service Table of Limits - SSP-1776*.

Fin Stabilizer Installation

NOTICE: Two different widths of fin stabilizers, 0.63 in. (16.00 mm) and 0.31 in. (7.87 mm) are to be installed on each engine cylinder in the locations shown in Figure A-3.

1. Clean the fin stabilizers and cylinder fin areas with mineral spirits or equivalent to remove all grease, dirt, and other unwanted materials.
2. Use compressed air to dry the stabilizers and fins.
3. Apply Dow Corning® Silastic® 140 adhesive to the cylinder fins (Figure A-4).
4. Install the fin stabilizers in the locations shown in Figure A-5.

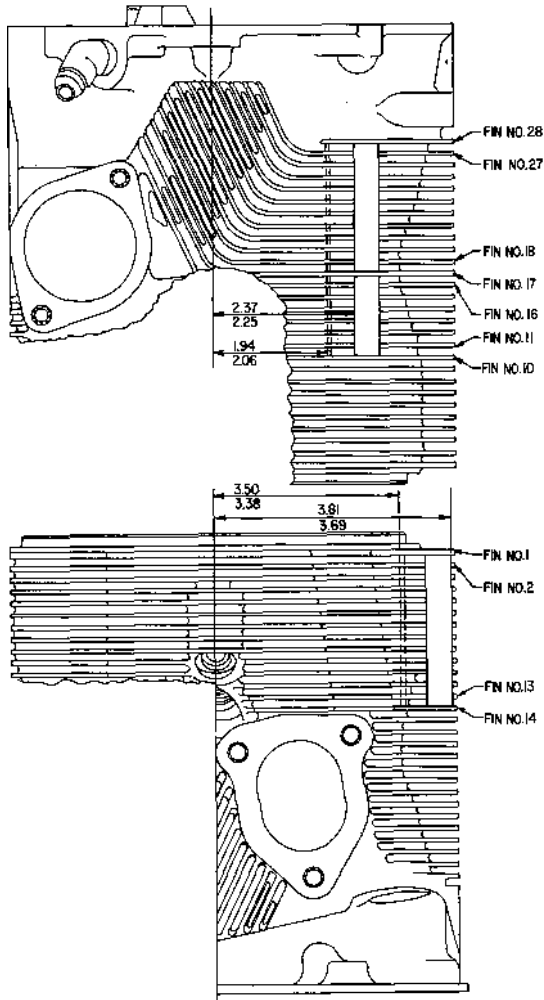


Figure A-3
Fin Stabilizer Locations



Figure A-4
Apply Adhesive



Figure A-5
Fin Stabilizer Installed on Cylinder

Install Stud at Oil Filter Pad (if Required)

1. Apply Food-Grade Anti-Seize to the stud for the oil filter pad.
2. Install the stud using stud driver height setter (Figure A-6).
3. Install the stud to a driven height of 0.60 to 0.64 in. (15.2 to 16.3 mm). Refer to Figure A-7.



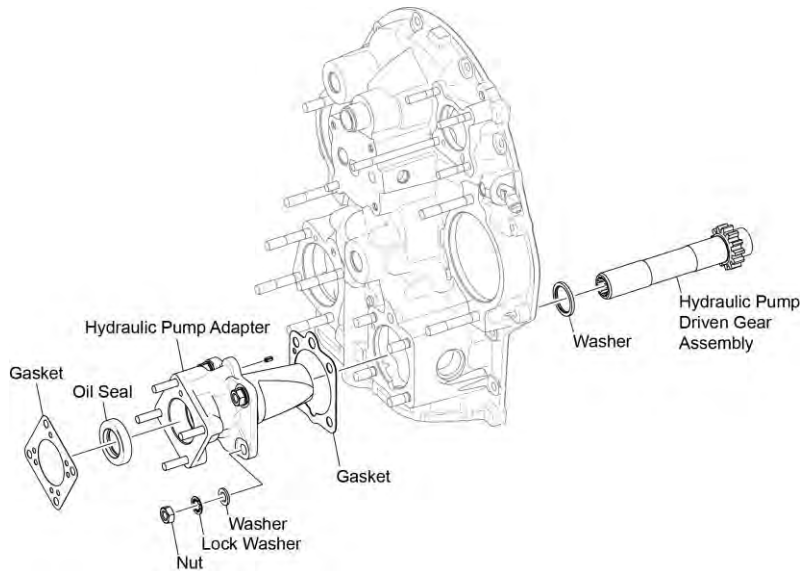
Figure A-6
Stud Driver and Trip Template



Figure A-7
Stud Driven Height 0.60 to 0.64 in.(15.2 to 16.3 mm).

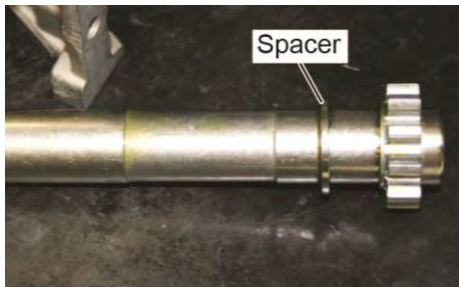
Hydraulic Pump Adapter Assembly Installation (if Required)

1. Lubricate the shaft of the hydraulic pump driven gear (Figure A-8) with engine oil mixture.

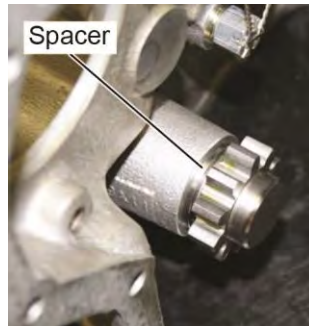


**Figure A-8
Hydraulic Pump Adapter Assembly**

2. Install the spacer on gear shaft. Refer to Figure A-9.
3. Install the gear shaft into the housing. Refer to Figures A-10 and A-11.



**Figure A-9
Gear Shaft**



**Figure A-10
Spacer on Gear Shaft**



**Figure A-11
Gear Shaft in Housing**

4. Apply a light coat of Loctite[®] 222 or equivalent to the hydraulic pump oil seal bore in the hydraulic pump adapter assembly (Figure A-8).
5. Install a new hydraulic pump oil seal in the hydraulic pump seal bore.

Hydraulic Pump Replacement (if Required)

1. Hydraulic Pump Removal

Remove the hydraulic pump from the accessory drive housing in accordance with the aircraft manufacturer's instructions.

2. Hydraulic Pump Installation

Install the hydraulic pump on the accessory drive housing in accordance with the aircraft manufacturer's instructions.