

SUPPLEMENT TO

Model O-340 Series Aircraft Engines Parts Catalog

NO. 105

This supplement is provided to inform users of Lycoming parts catalogs of changes, deletions, additions and supersedures that have occurred since publication of the catalog.

		Quantity per Engine
Crankcase Assembly, Machining	72667 instead of 71588	1
Stud	69679 instead of 68751	2
Stud	61261	2
Stud	67528	1
Washer	Std-425	AR - max. 3
Spacer, Oil pressure relief valve	73629 - 73630	1 of either required
Bearing, Crankshaft	73048 instead of 69961	4
Bearing, Crankshaft, front	75210 instead of 68527 or 71637	1
Seal, Crankshaft oil	71879-S instead of 60734	1
Plate, Crankshaft oil seal retaining	73952	2
Attaching Parts (for above plate)		
Washer	Std-160	6
Screw	Std-1919	6
Seal, Oil	72075	6
Ring, Oil seal	72091	2
Body, Hydraulic tappet	72877 instead of 69529	8
Plunger Assembly, Hydraulic tappet	76290 instead of 68312, 71791, 72876 or 73062	8
Crankshaft Assembly	71566	1
Bushing, Propeller flange	72065-S instead of 69838	1
Bushing, Propeller flange	72063-S instead of 69836	3
Bushing, Propeller flange	72064-S instead of 69837	2
Crankshaft Assembly	71567	1
Bushing, Propeller flange	72065-S instead of 69838	1
Bushing, Propeller flange	72063-S instead of 69836	5
Camshaft Assembly	74167 instead of 68769	1
Slinger, Breather	72079 instead of 68613	1
Lockplate	72078 instead of 66144	2
Bolt, Connecting rod	74669 instead of 69459	8
Nut, Connecting rod	74646 instead of 71950	8
Pin	Std-1853 instead of Std-543	8
Bearing, Connecting rod	69373 instead of 61662	8
Lockplate	73817 instead of 61864	2
Piston	75089 instead of 74530, 72967 or 71594	4
Ring, Piston, compression	74241 instead of 72446 or 68513	8
Ring, Piston, oil regulator expander type	73857 instead of 69457	4
Cylinder and Head Assembly	75187 instead of 73150, 71846 or 69538	4
Guide, Exhaust valve	74230 instead of 69533	4
Valve, Intake	73938 instead of 72625 or 67905	4
Valve, Exhaust, rotator type	74541 instead of 71595	4
Cap, Valve stem, exhaust	MS13998-3 instead of 62388	4
Seat, Valve spring, upper, exhaust	73115 instead of 69532	4
Key, Valve, exhaust	MS13997-3 instead of 72050	8
Gasket, Rocker box cover	75906 instead of 61246	4
Screw (required to attach rocker box cover)	Std-1925 instead of Std-1826	24
Rod Assembly, Push	73417 instead of 69467	AR
Rod Assembly, Push	73418 instead of 69468	AR
Rod Assembly, Push	73419 instead of 69469	AR
Rod Assembly, Push	73420 instead of 69469-1	AR
	(A total of 8 push rod assemblies required)	
Rocker Assembly, Valve, intake	69444 (4) instead of 69444 (8)	
Rocker Assembly, Valve, exhaust	74636	4
Bushing, Valve rocker, exhaust	74637	4
Clamp, Hose	Std-1924 instead of Std-1252	8
Gasket, Accessory housing	73818 instead of 61352	1
Housing Assembly, Accessory	72498 instead of 68634	1
Housing Assembly, Accessory	72501	1

		Quantity per Engine
Housing Assembly, Accessory	72503	1
Housing Assembly, Accessory	72504	1
Gear Assembly, Crankshaft idler, plain	74996 instead of 61278	2
Gear Assembly, Crankshaft idler, plain (optional equipment)	74996 instead of 61278	1
Gear Assembly, Crankshaft idler, plain (optional equipment)	75072 instead of 61152	1
Drive Stud (required to attach nameplate)	Std-1901 instead of AN535-4-3	4
Ring, Oil level gage seal	74068 instead of 72059 or 60895	1
Tube, Oil level gage, long	75736 instead of 69098	1
Clamp, Hose	Std-1530 instead of Std-1831	8
Flange, Intake pipe, upper	73346 instead of 60069	4
Magneto, (type S4LN-204) (optional equipment)	72524	1
Magneto, (type S4LN-200) (optional equipment)	73360	1
Shielding Assembly, Ignition (Co-Op.)	73371	1
Cable Assembly, Ignition shielded (optional equipment)	75846	1
Link, Generator adjusting	76028 instead of 60861	1
Regulator, Voltage	72205 instead of 62831	1
Regulator, Voltage	72077	1
Support Assembly, Starter ring gear	74414 instead of 68867	1
Gear, Starter ring	72566 instead of 60882	1
Screw	Std-1884	4
Valve Assembly, Temperature control oil cooler by-pass (optional equipment)	75944 instead of 69451	1
Starter, 12 volt	76211 instead of 74092 or 69952	1
Starter, 24 volt	76212 instead of 72462 or 69953	1
Gear Assembly, Vacuum pump driven (Optional equipment)	72970 instead of 61164	1
Fuel Pump	75246 instead of 74082, 74060, 73297, 71537, 69497 or 62628	1
Plug, Allen	Std-783 instead of Std-47	1
Adapter Assembly, Propeller governor (optional equipment)	75153 instead of 69000	1
Adapter Assembly, Propeller governor (optional equipment)	75545 instead of 68531	1
Nipple	75738 instead of AN822-5-4D	1
Cover, Governor drive	72378 instead of 180-G	1
Baffle Assembly, Intercylinder	72151 instead of 69666	2
Retainer, Intercylinder baffle	71611 instead of 65883	2
Hook, Intercylinder baffle, retainer	71610 (2) instead of 1892 (2), Std-28 (4) or Std-670 (2)	
Clamp, Primer line	71910	3
Nipple Assembly, Primer	74225	3
Spark Plug	1182-B3	8
Spark Plug	1182-F3	8

**LYCOMING MODEL O-340 SERIES AIRCRAFT ENGINES**

**TABLE OF CONTENTS**

<b>INTRODUCTION . . . . .</b>	<b>111</b>
<b>INSTRUCTIONS FOR ORDERING PARTS . . . . .</b>	<b>111</b>
<b>ILLUSTRATED PARTS SECTION . . . . .</b>	<b>1</b>
<b>NUMERICAL PARTS LIST . . . . .</b>	<b>12</b>
<b>NUMERICAL STANDARD PARTS LIST . . . . .</b>	<b>24</b>
<b>NUMERICAL OVERSIZE AND UNDERSIZE LIST . . . . .</b>	<b>27</b>
<b>SERVICE REPLACEMENT SET SECTION . . . . .</b>	<b>28</b>
<b>ATTACHING PARTS SECTION . . . . .</b>	<b>30</b>

# LYCOMING MODEL 0-340 SERIES AIRCRAFT ENGINES

## INTRODUCTION

The parts lists and illustrations in this catalog provide an easy method of identification, for procurement and servicing purposes, of any part used on Lycoming Model 0-340 Series Aircraft Engines. The catalog contains six sections which are described in the following paragraphs.

**THE ILLUSTRATED PARTS SECTION** consists of exploded views of the basic 0-340 Series engines. These views illustrate all procurable parts which are indicated and identified by part number.

**THE NUMERICAL PARTS SECTION** contains the part number of all procurable parts used on these engines and are arranged in numerical sequence. Following each part listing a complete dimensional description is given, along with the quantity required for each engine. If the part is an assembly the quantity, part number and name of its components are given. Certain components of these assemblies may be prefixed by an (\*) which indicates that the detail part cannot be procured as such but can be obtained only by ordering the next higher assembly of which it is a component.

**THE NUMERICAL STANDARDS PARTS SECTION** is similar to the Numerical Parts Section excepting only that the part numbers are prefixed by the symbol "STD". This symbol indicates that the part is a Lycoming standard part and is not necessarily peculiar to these engines. The standard parts include such items as nuts, bolts, washers, and seals.

**THE OVERSIZE AND UNDERSIZE PARTS SECTION** consists of a list of such parts that are available in sizes other than nominal or standard. This list states the part name or number of the part and the non standard sizes in which it may be procured.

**THE SERVICE REPLACEMENT SET SECTION** consists of a list of service replacement sets such as seals, gaskets or complete cylinder, piston and ring combinations. The individual items in these sets are listed separately in the Numerical Section of the catalog and may be individually procured.

**THE ATTACHING PARTS SECTION** consists of a complete listing of all assemblies and subassemblies contained in the engine, along with their attaching parts. These assemblies and subassemblies are arranged in an alphabetical sequence and immediately beneath each listing are shown the parts that are required to attach each assembly. The quantity shown under the "No. Required" column are for one assembly only.

## INSTRUCTIONS FOR ORDERING PARTS

Always, when ordering parts, state the part number, its correct name, and quantity desired. In addition state the complete model and serial number of the engine. This information will be found on the Name Plate which is attached to the sump. Unless credit has been established with Lycoming, all parts will be shipped C.O.D. or with sight draft attached to bill of lading on freight shipment.

**WHEN ORDERING PARTS BE CERTAIN TO INCLUDE ENGINE MODEL AND SERIAL NUMBER.**



LYCOMING MODEL O-340 SERIES AIRCRAFT ENGINES

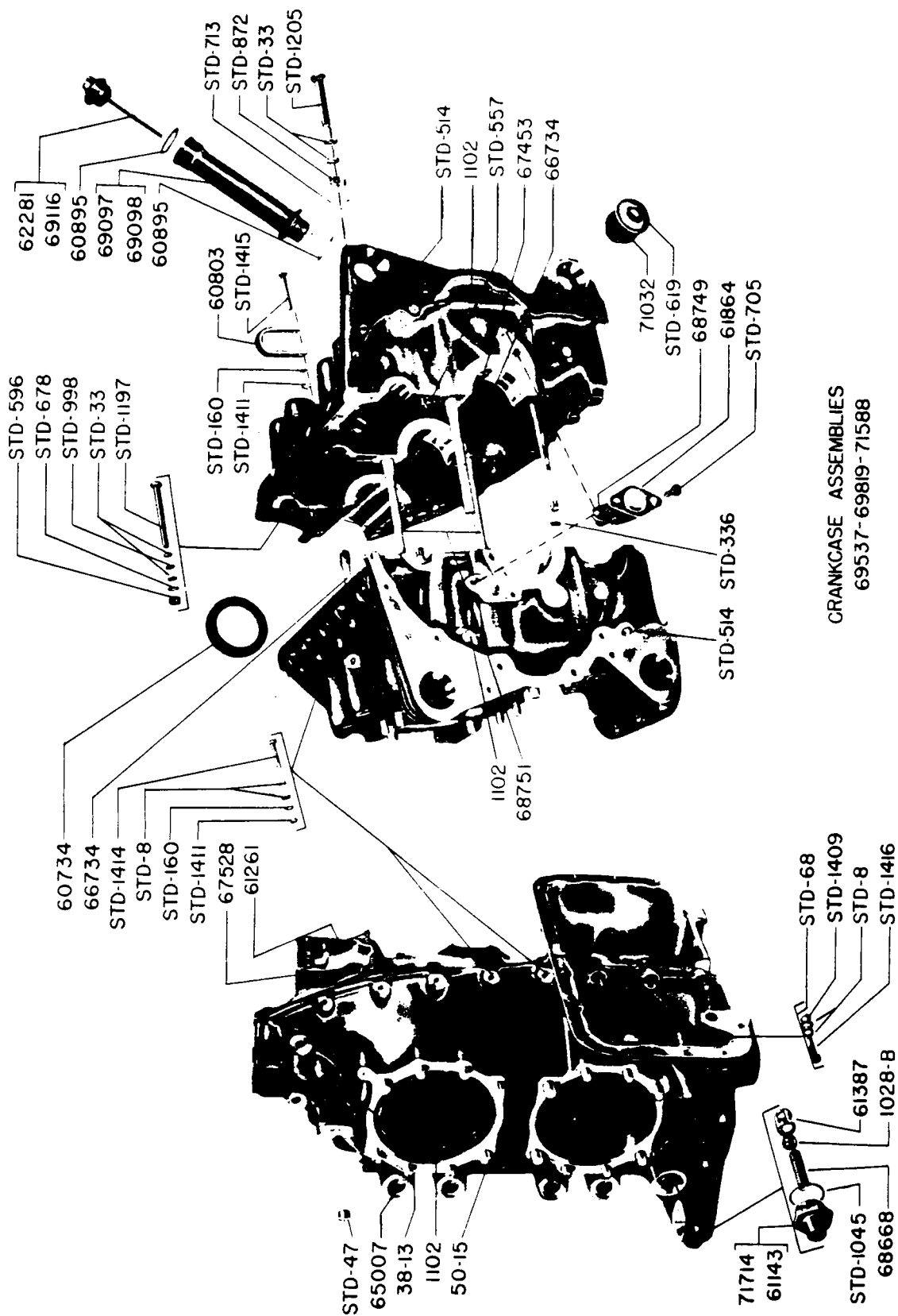

CRANKCASE ASSEMBLIES  
69537-69819-71588

Figure 2 - Crankcase and Related Parts

LYCOMING MODEL O-340 SERIES AIRCRAFT ENGINES

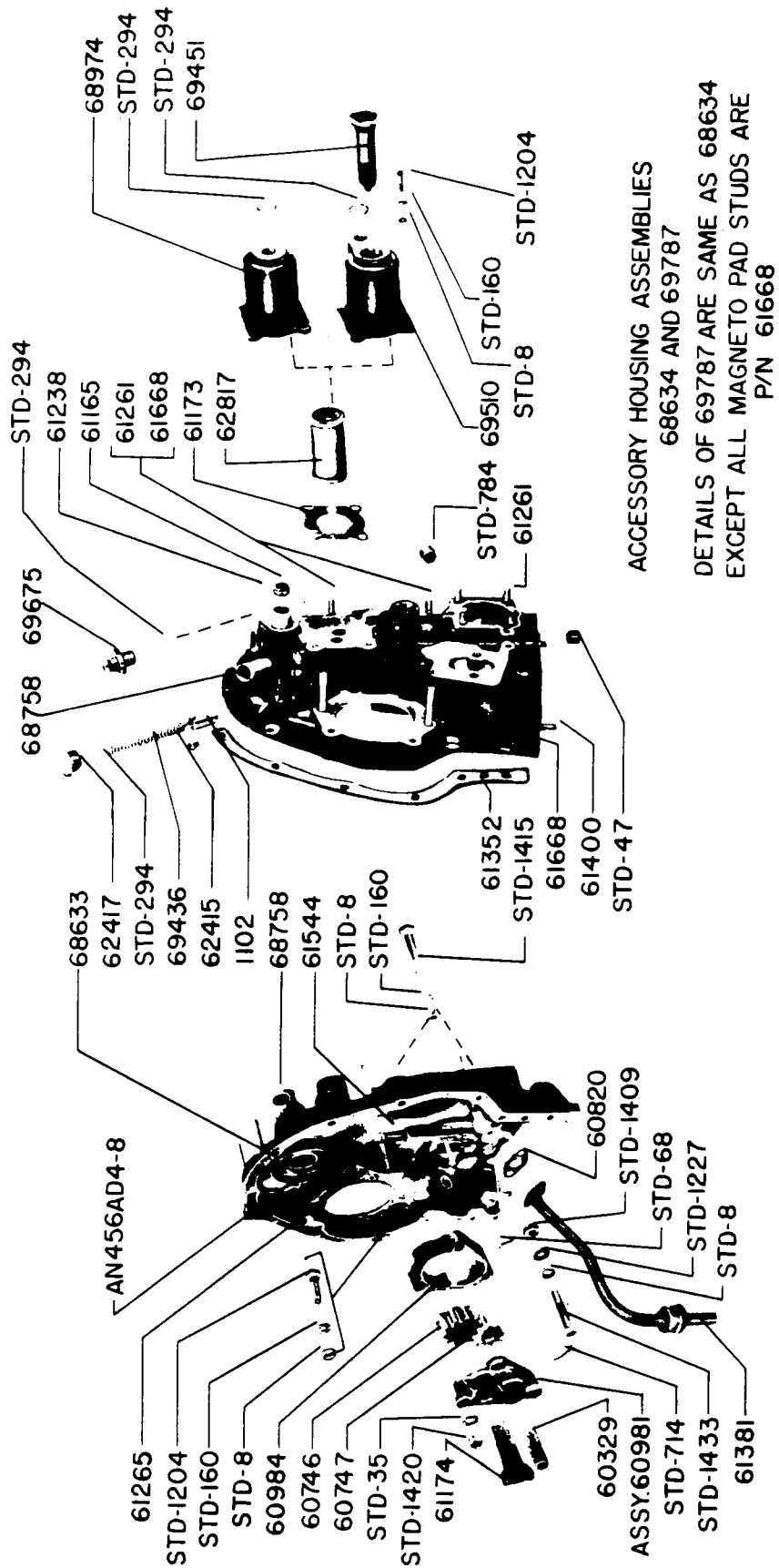

Figure 3 - Accessory Housing Assy

LYCOMING MODEL O-340 SERIES AIRCRAFT ENGINES

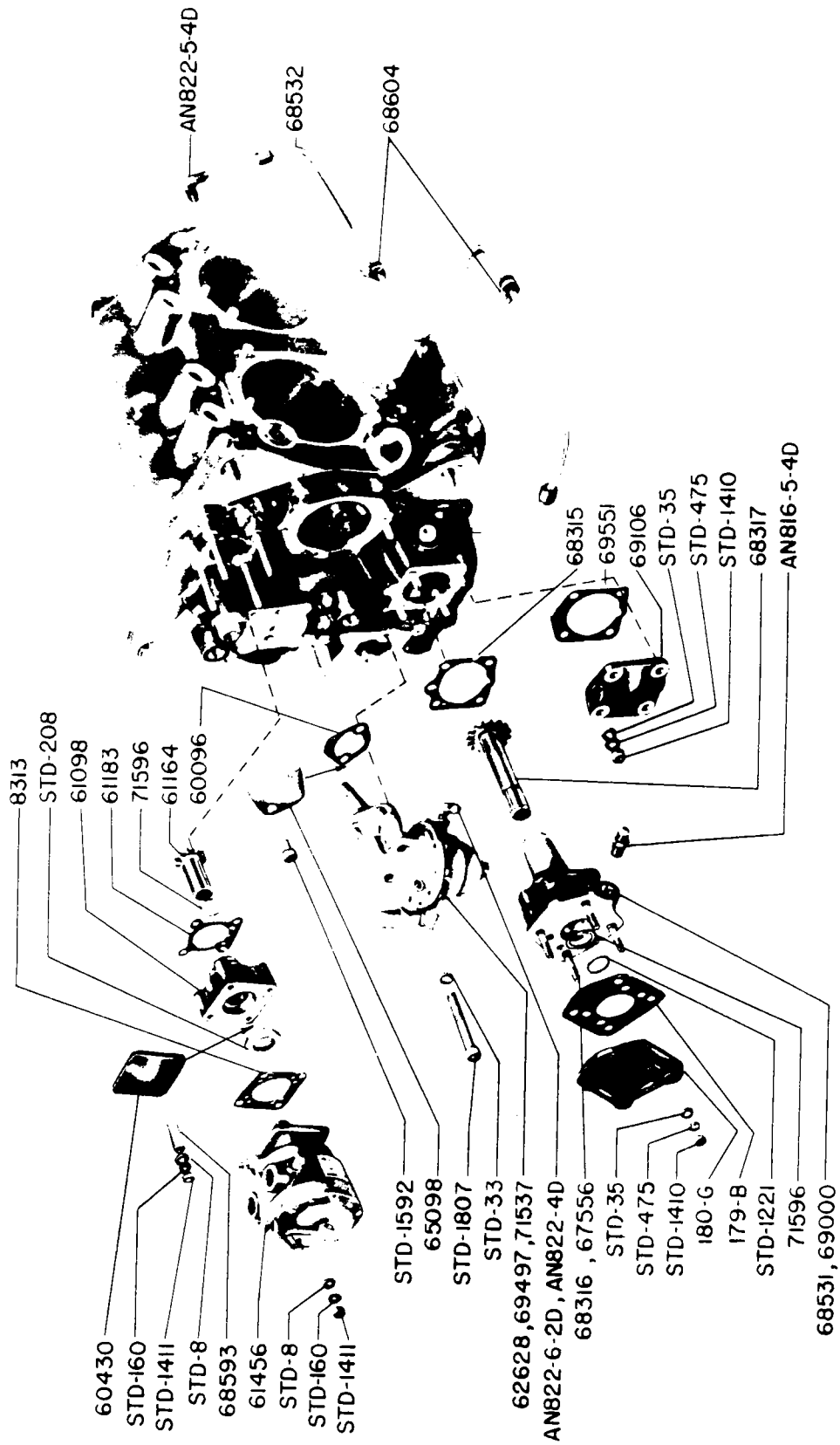

Figure 4 - Propeller Governor, Fuel and Vacuum Pump and Drives



LYCOMING MODEL O-340 SERIES AIRCRAFT ENGINES

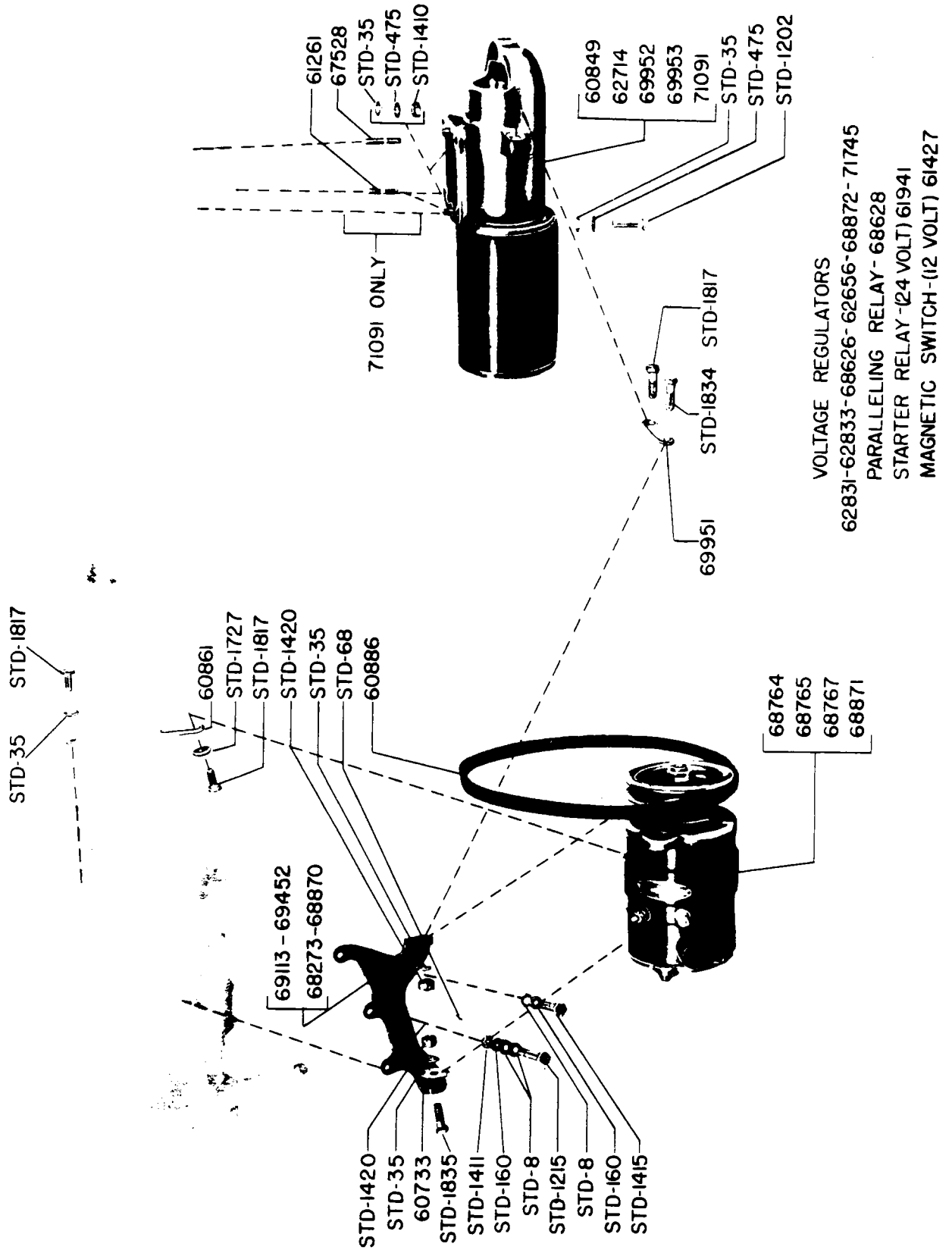

Figure 5 - Starter, Generator and Voltage Regulator

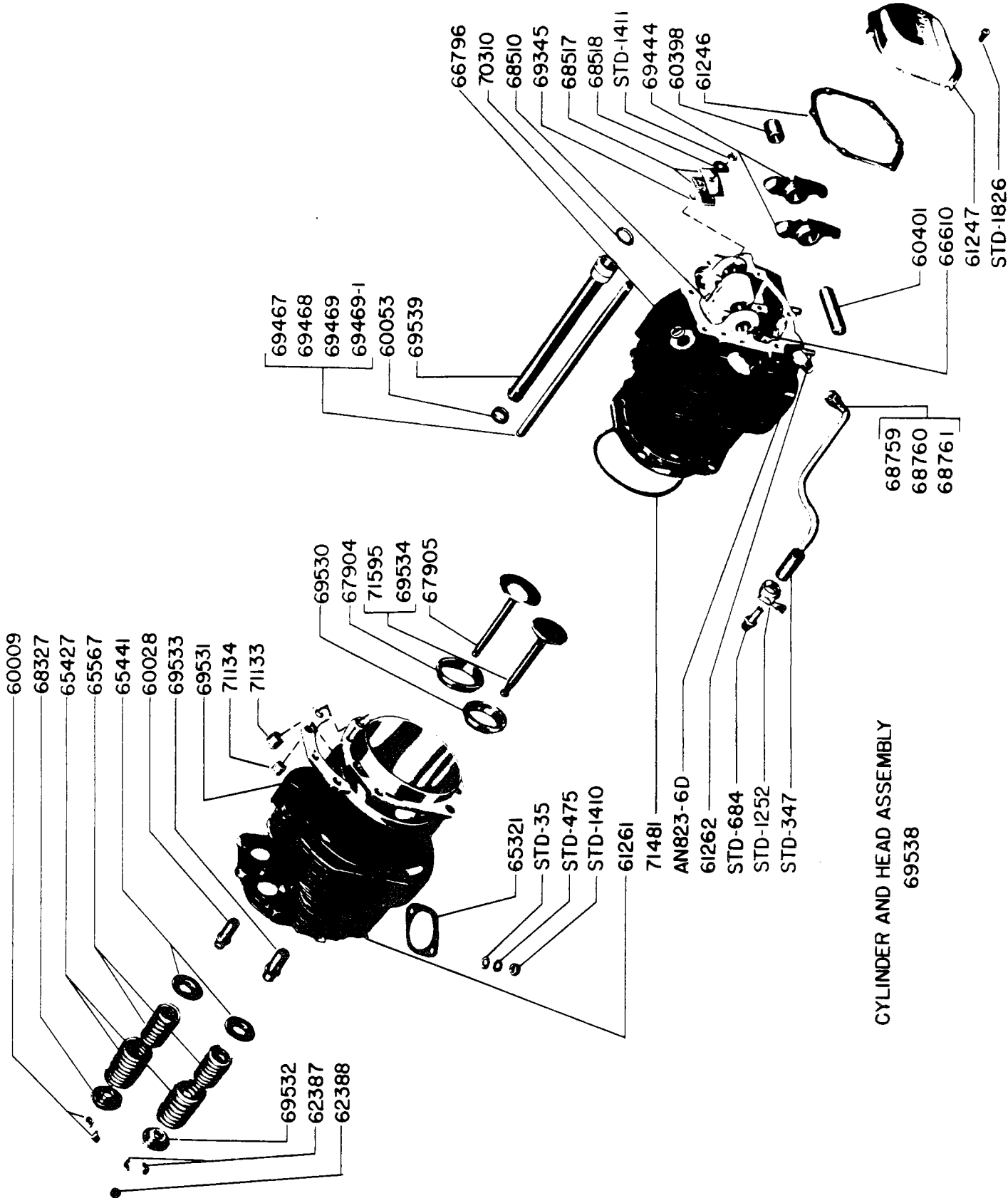
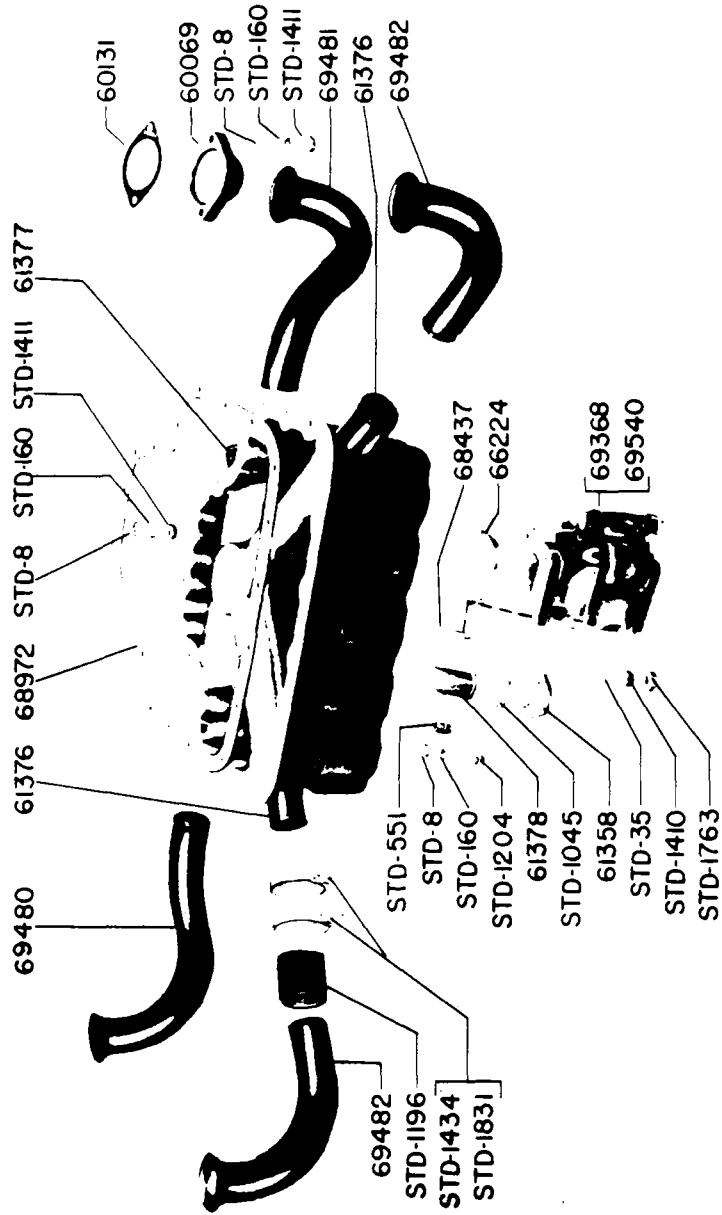

Figure 6 - Cylinder and Head Assembly

LYCOMING MODEL O-340 SERIES AIRCRAFT ENGINES



SUMP ASSEMBLY  
69370

Figure 7 - Oil Sump Assembly

LYCOMING MODEL O-340 SERIES AIRCRAFT ENGINES

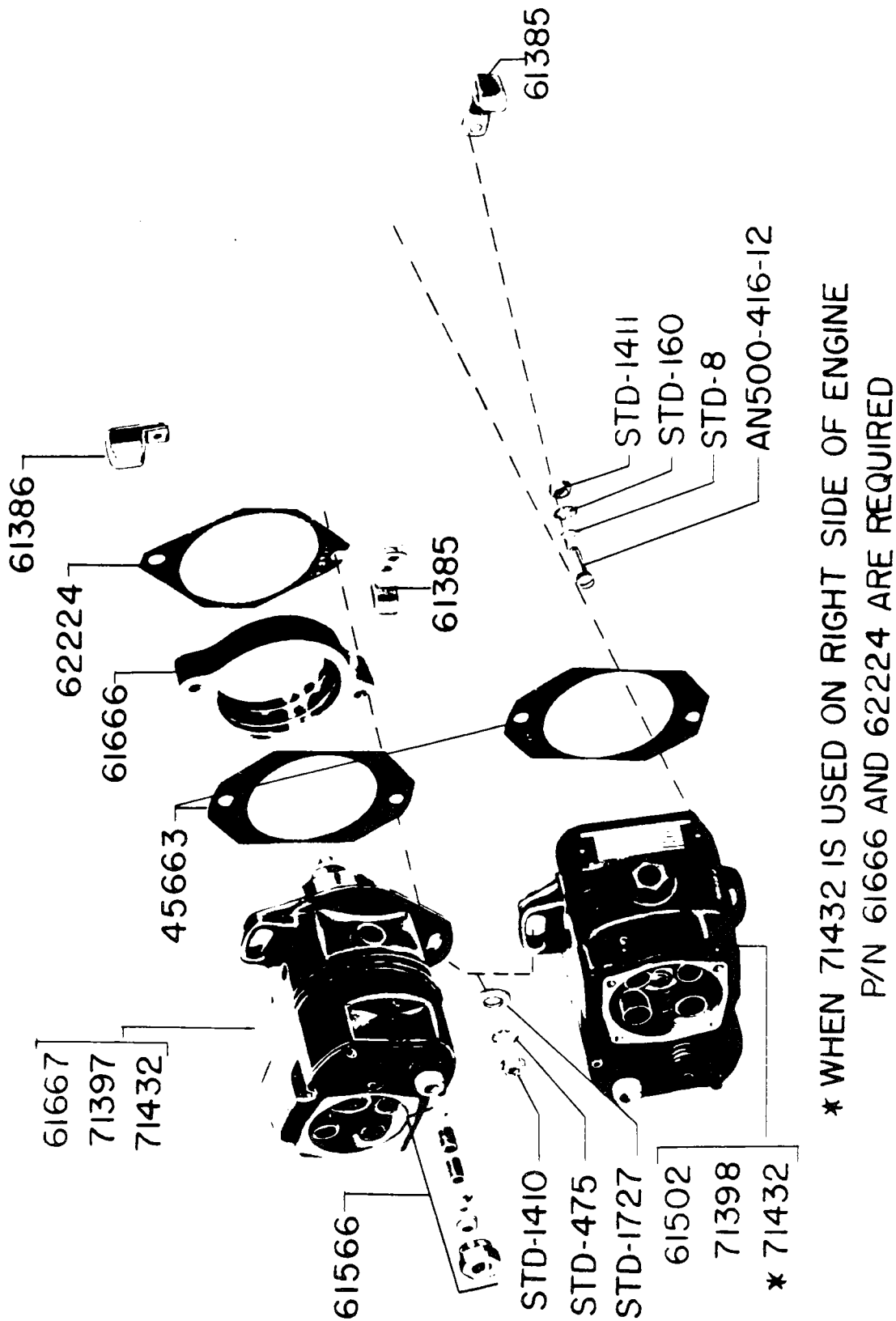

Figure 8 - Magnetos and Magneto Drives

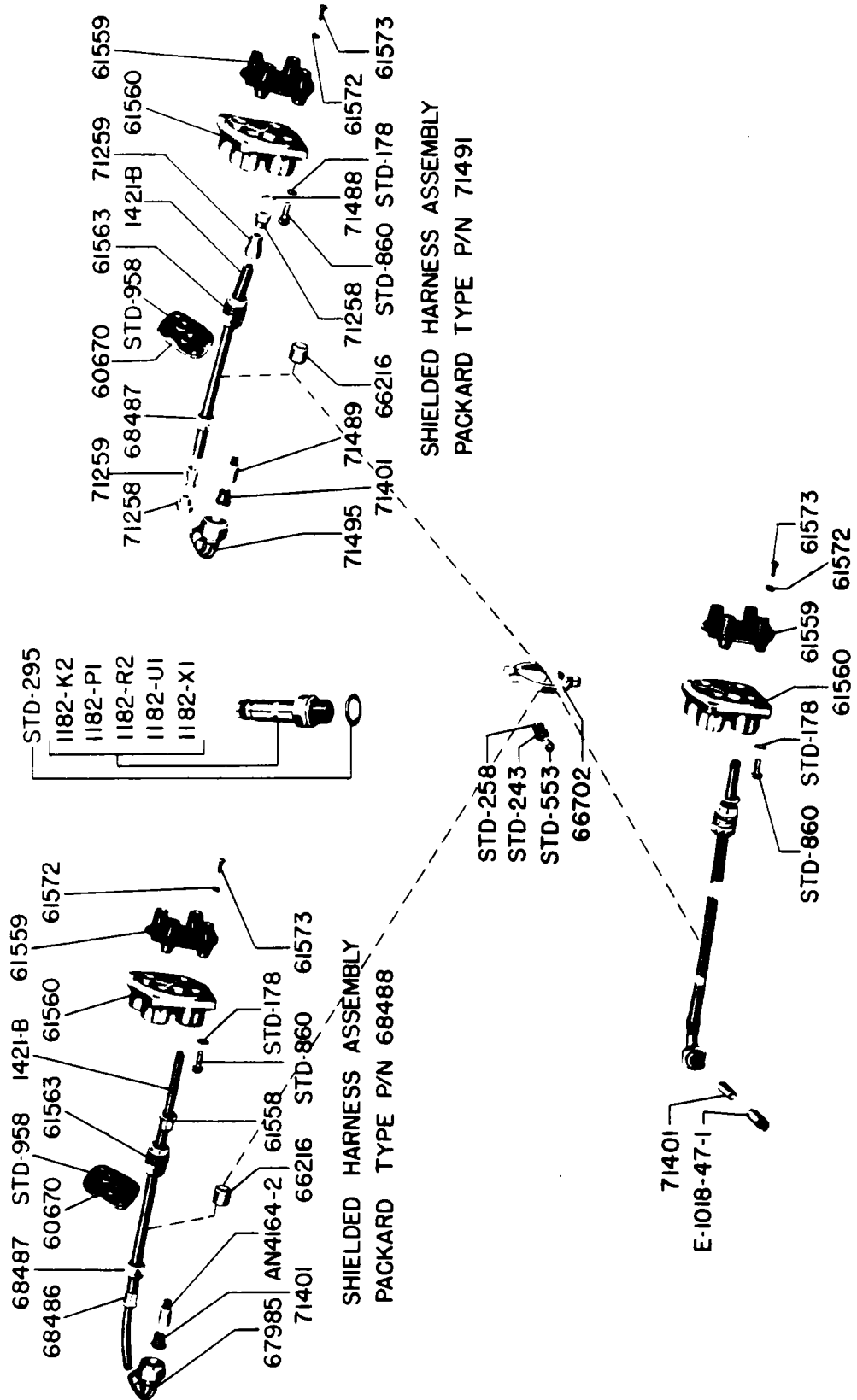

Figure 9 - Ignition Harness Assemblies

LYCOMING MODEL O-340 SERIES AIRCRAFT ENGINES

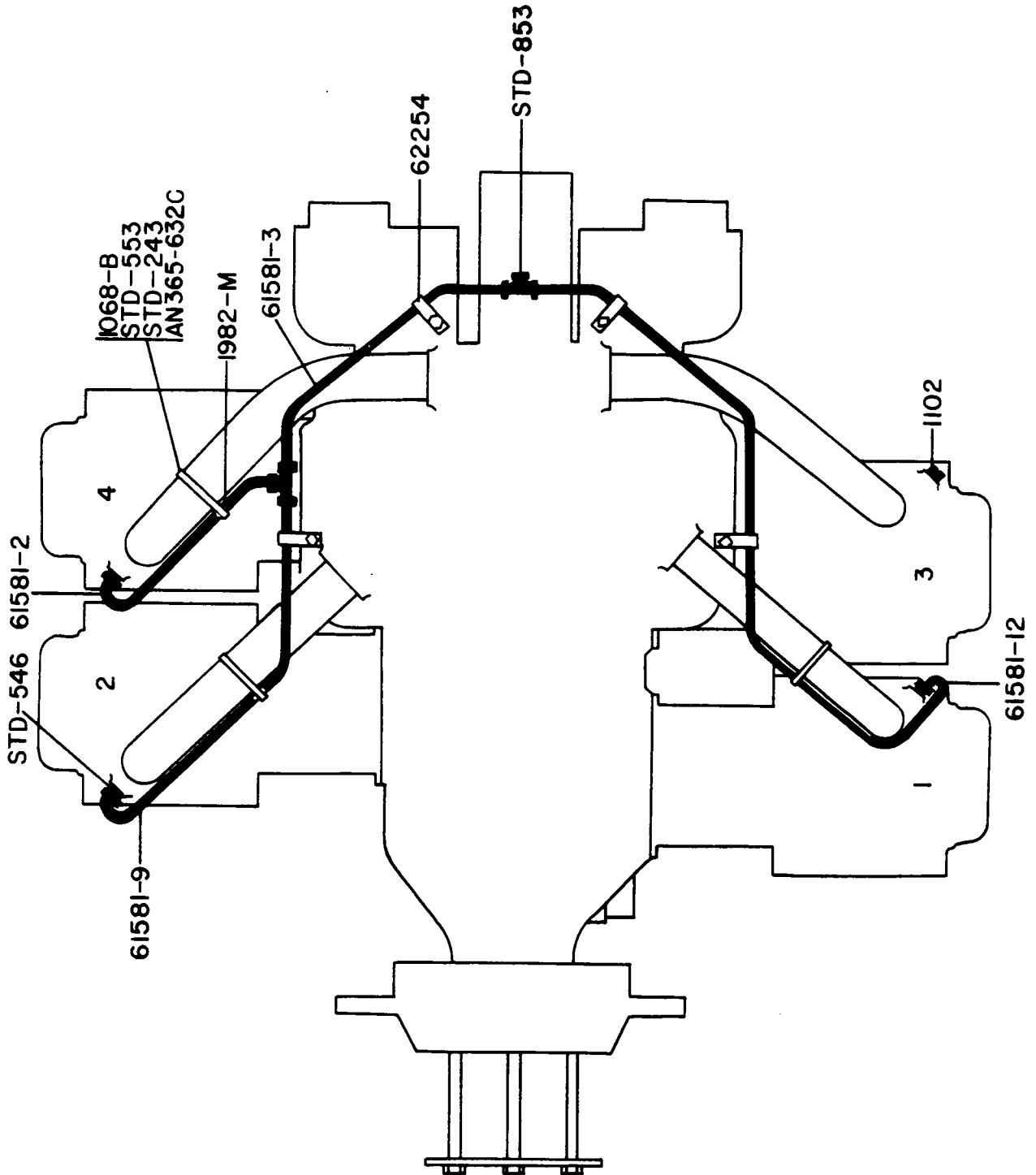

Figure 10 - Priming System

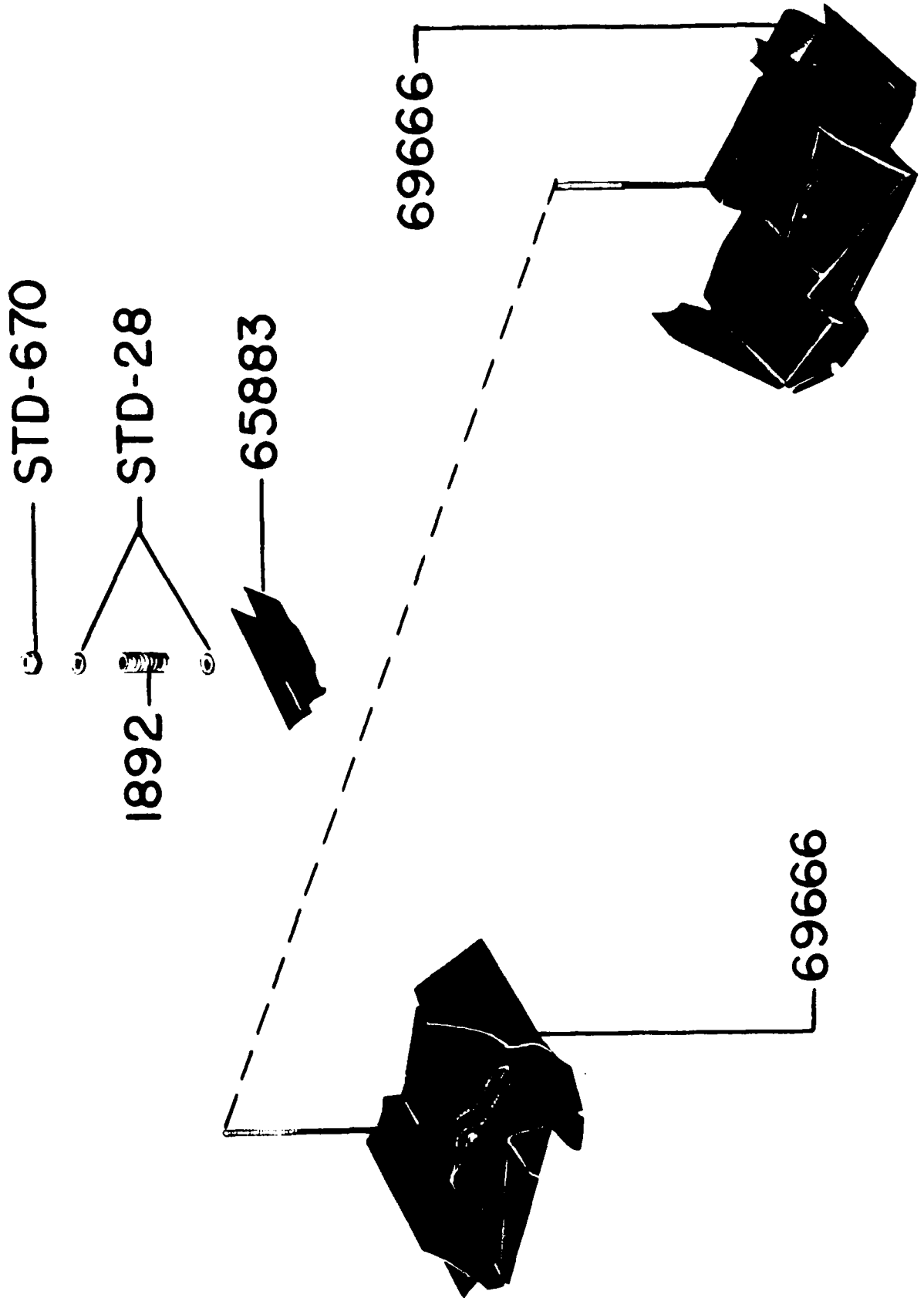

Figure 11 - Cooling Baffles

LYCOMING MODEL O-340 SERIES AIRCRAFT ENGINES

NUMERICAL PARTS LIST

Part Number	Part Name	No. Req'd.	
		MODEL A	MODEL B
38-13	STUD, 3/8-16 x 1-5/8 in. long . . . . .	16	16
50-15	STUD, 1/2-13 x 1-7/8 in. long . . . . .	8	8
179-B	GASKET, Governor . . . . .	1	-
180-G	COVER, Governor drive . . . . .	1	-
235	SLEEVE, Spark plug (Packard type shielding only) (Superseded by AN4164-2 and 71401)	8	8
1028-B	BALL, 11/16 in. dia. . . . .	1	1
1068-B	CLAMP, Primer line . . . . .	3	3
1102	PLUG, 1/8 NPT x 3/8 in. long, socket (Remove one from cylinders 1, 2 and 4 when primer system is employed)	10	10
1182-K2	SPARK PLUG (Same as AC S86R) Alternate to 1182-U1 . . . . .	8	-
1182-P1	SPARK PLUG (Same as Champion C-26-S) . . . . .	-	8
1182-R2	SPARK PLUG (Same as AC-S88D) Alternate to 1182-U1 . . . . .	8	8
1182-U1	SPARK PLUG (Same as Champion RC-26-S) . . . . .	8	-
1182-X1	SPARK PLUG (Same as Champion C-27-S) Alternate to 1182-P1) . . . . .	-	8
1421-B	CABLE, Shielded, high tension (Packard Type) . . . . .	AR	AR
1892	SPRING, Cylinder baffle . . . . .	2	2
1982-M	LOOM, Priming line . . . . .	3	3
8313	GASKET, Vacuum pump . . . . .	1	-
45663	GASKET, Magneto . . . . .	2	2
60009	KEY, Valve . . . . .	8	8
60028	GUIDE, Valve, intake . . . . .	4	4
60053	SEAL, Shroud tube . . . . .	8	8
60069	FLANGE, Intake pipe, upper . . . . .	4	4
60096	GASKET, Fuel pump . . . . .	1	1
60131	GASKET, 2 bolt flange, 1-3/4 ID . . . . .	4	4
60329	SHAFT, Oil pump idler . . . . .	1	1
60398	BUSHING, Valve rocker . . . . .	8	8
60401	SHAFT, Valve rocker . . . . .	4	4
60430	COVER, Vacuum pump . . . . . (Req'd. only when no vacuum pump is used)	1	1
60449	TUBE, Crankpin oil . . . . .	4	4
60670	PLATE, Spark plug cable . . . . . (Not req'd. with Breeze shielding)	2	2



LYCOMING MODEL O-340 SERIES AIRCRAFT ENGINES

NUMERICAL LIST

Part Number	Part Name	No. Req'd.	
		MODEL A	MODEL B
60733	SHIM, 1-1/8 OD x 11/32 ID x .005 thick Used only with generator brackets 68870 and 69452 to establish maximum end clearance of .005 in. between bracket and generator rear flange.	AR	-
60734	SEAL, Crankshaft oil	1	1
60746	IMPELLER, Oil pump driving	1	1
60747	IMPELLER, Oil pump driven	1	1
60803	STRAP, Lifting	1	1
60820	GASKET, Oil suction tube flange	1	1
60828	PLUG, Piston pin	8	8
60849	STARTER, 12 volt (Superseded by 69952) (Same as Delco Remy P/N 1109657) These starters are identical except 69952 has a lug cast into its front housing, providing a means of tying the generator and starter together by use of a generator strut P/N 69951.	1	-
60861	LINK, Generator adjusting	1	1
60869	WASHER, Accessory driven gear (Superseded by and interchangeable with P/N 71596)	2	-
60882	GEAR, Starter ring	1	1
60886	BELT, Generator drive	1	-
60895	GASKET, Oil level gage	2	2
60981	COVER ASSY, Oil pump Consists of: 1 60329 Shaft 1 STD714 Pin 1 60983 Cover	1	1
60983	COVER, Oil pump	1	1
60984	BODY, Oil pump	1	1
61098	ADAPTER ASSY, Vacuum pump (Includes seal P/N STD208)	1	-
61143	PLUG, Oil relief valve (Superseded by and interchangeable with 71714)	1	1
61152	GEAR ASSY, Crankshaft idler Consists of: 1 * 61153 Gear 1 61154 Bushing (Req'd. for fuel pump drive along with plunger 61544)	1	1
61154	BUSHING, Crankshaft idler gear	2	2
61155	GEAR, Crankshaft	1	1
61156	LOCKPLATE, Crankshaft gear	1	1
61163	GEAR, Magneto	1	1

LYCOMING MODEL O-340 SERIES AIRCRAFT ENGINES

NUMERICAL PARTS LIST

Part Number	Part Name	No. Req'd.	
		MODEL A	MODEL B
61164	GEAR ASSY, Vacuum pump driven . . . . .	1	-
61165	SEAL, Oil, tachometer drive . . . . .	1	1
61173	GASKET, Oil pressure housing . . . . .	1	1
61174	SHAFT, Oil pump drive . . . . .	1	1
61183	GASKET, Accessory adapter . . . . .	1	1
61238	STUD, 1/4-20 x 2-25/32 in. long . . . . .	4	4
61246	GASKET, Rocker box cover . . . . .	4	4
61247	COVER, Rocker box . . . . .	4	4
61261	STUD, 5/16-18 x 1-1/2 in. . . . .	8	6
61262	STUD, 1/4-20 x 1-17/32 in. . . . .	8	8
61265	STUD, 5/16-18 x 2-3/16 in. dr. . . . .	3	3
61278	GEAR ASSY, Crankshaft idler, plain . . . . .	2	1
	Consists of:		
	1 * 61277 Gear 1 61154 Bushing		
	(When fuel pump drive is req'd., one of the 61278 gear assemblies is replaced by 61152 gear assy and fuel pump plunger 61544 is added)		
61352	GASKET, Accessory housing . . . . .	1	1
61358	PLUG, 1-1/2 hex hd. x 1-1/4-20 thread . . . . .	1	1
61376	CONNECTION, Intake pipe, front . . . . .	2	2
61377	CONNECTION, Intake pipe, front . . . . .	2	2
61378	SCREEN, Oil suction . . . . .	1	1
61381	TUBE ASSY, Oil suction . . . . .	1	1
61385	CLIP, Ignition cable . . . . .	2	2
61386	CLIP, Ignition cable (Not req'd. with Breeze shielding) . . . . .	1	1
61387	SLEEVE, Oil relief valve . . . . .	1	1
61400	STUD, 1/4-20 x 1-3/16 long . . . . .	2	2
61427	SWITCH, Magnetic (For use with 12 volt system only) (Same as Delco Remy P/N 001464)	1	-
61456	PUMP, Vacuum (Same as Pump Engineering Service Corp., Model 3P-194-FA type B-11)	1	-
61502	MAGNETO (Same as Scintilla type S4LN-20 P/N 10-51360-11) . . . . . Superseded by 71398	1	-
61510	PLUG, 1-3/4 in. O.D. (Req'd. in crankshaft assemblies 69478 and 71566) . . . . .	1	-
61544	PLUNGER, Fuel pump, long . . . . .	1	-

LYCOMING MODEL O-340 SERIES AIRCRAFT ENGINES

NUMERICAL PARTS LIST

Part Number	Part Name	No. Req'd.	
		MODEL A	B
61548	NAMEPLATE . . . . .	1	1
61558	FERRULE, Ignition cable, shielded (Packard type shielding only) . . . . .	8	8
61559	GROMMET, Ignition cable, four wire . . . . .	2	2
61560	PLATE, Ignition cable outlet, shielded . . . . .	2	2
61563	NUT, Coupling 11/16-24 Rd. (Packard type shielding only) . . . . .	8	8
61565	KIT ASSY, Ignition cable, shielded (Packard type only) . . . . .	2	2
	Consists of:		
	1 61559 Grommet 4 61573 Screw		
	1 61560 Plate 4 STD178 Washer		
	4 61572 Washer 4 STD860 Screw		
61566	KIT ASSY, Magneto ground terminal (Procurable as an assembly only) . . . . .	2	2
61572	WASHER, 9/32 OD x 1/8 ID x .025 thick (Packard type only) . . . . .	8	8
61573	SCREW, Ignition cable fastening (Packard type only) . . . . .	8	8
61581-2	TUBE ASSY, Primer, cylinder No. 4 . . . . .	1	1
61581-3	TUBE ASSY, Primer, intercylinder . . . . .	1	1
61581-9	TUBE ASSY, Primer, cylinder No. 2 . . . . .	1	1
61581-12	TUBE ASSY, Primer, cylinder No. 1 . . . . .	1	1
61662	BEARING, Connecting rod . . . . .	8	8
61665	GEAR, Magneto (Impulse coupling) . . . . .	1	2
61666	ADAPTER, Magneto (Impulse coupling) . . . . .	1	2
61667	MAGNETO (Impulse coupling) (Same as Scintilla type S4LN-21, P/N 10-51360-12) Superseded by 71397	1	-
61668	STUD, 5/16-18 x 2-3/8 in. long . . . . .	2	4
61864	LOCKPLATE, 1/4 bolt x 1-3/4 in. spacing . . . . .	2	2
61941	RELAY, Type B6B (Same as Guardian Electric Co. P/N 34810-A) (For use with 24 volt system only)	1	-
62224	GASKET, Magneto adapter . . . . .	1	2
62254	CLIP, Screw, 3/16 ID for 1/4 in. dia. . . . .	4	4
62281	GAGE ASSY, Oil level (Standard) . . . . .	1	1
62387	KEY, Valve . . . . .	8	8
62388	CAP, Valve stem . . . . .	4	4
62415	PLUNGER, Oil cooler by-pass (Not req'd. with thermostatic oil by-pass valve)	1	-
62417	PLUG, Oil cooler by-pass (Not req'd. with thermostatic oil by-pass valve) . . . . .	1	-

LYCOMING MODEL O-340 SERIES AIRCRAFT ENGINES

NUMERICAL PARTS LIST

Part Number	Part Name	No. Req'd.	
		MODEL A	MODEL B
62530	BUSHING, Propeller flange		
	Crankshaft assy 69478 . . . . .	3	-
	Crankshaft assy 71033 . . . . .	5	-
62628	PUMP, Fuel (Same as AC type AH dwg. No. 5594068) . . . . .	1	-
62656	REGULATOR, Voltage (Same as Delco Remy P/N 1118386) (For use with 24 volt 15 amp generator only)	1	-
62714	STARTER, 24 volt (Superseded by 69953) (Same as Delco Remy P/N 1109669) These starters are identical except that 69953 has a lug cast into its front housing whereby a means is provided by tying the generator and starter together by use of generator strut P/N 69951.	1	-
62817	SCREEN ASSY, Oil pressure . . . . .	1	1
62831	REGULATOR, Voltage (Same as Delco Remy P/N 1118736) (For use with 12 volt 20 amp generator)	1	-
62833	REGULATOR, Voltage (Same as Delco Remy P/N 1118704) (For use with 12 volt 35 amp generator)	1	-
65007	RETAINER, Shroud tube seal . . . . .	8	8
65074	SOCKET, Hydraulic tappet push rod . . . . .	8	8
65098	COVER, Fuel pump . . . . .	1	1
65321	GASKET, Exhaust flange . . . . .	4	4
65427	SPRING, Valve, outer . . . . .	8	8
65441	SEAT, Valve spring, lower . . . . .	8	8
65567	SPRING, Valve, auxiliary . . . . .	8	8
65819	BUSHING, Connecting rod . . . . .	4	4
65883	CLAMP, Cylinder baffle . . . . .	2	2
66144	LOCKPLATE, 5/16 bolt and 1.33 spacing . . . . .	2	2
66216	SLEEVE, Ignition cable, shielded (Packard type shielding only) . . . . .	4	4
66224	GASKET, Carburetor . . . . .	1	1
66610	BUSHING, Rocker shaft . . . . .	16	16
66702	CLAMP, 1-3/4 ID with 7/16 in. dia. offset . . . . .	4	4
66734	STUD, 1/2-13 x 9-7/8 in. long . . . . .	4	4
66796	INSERT, Spark plug, 18-1.5 MM . . . . .	8	8
67453	DOWEL, Crankshaft bearing . . . . .	6	6
67528	STUD, 5/16-18 x 1-5/8 in. long (Crankcase assy 71588 only) . . . . .	1	-
67556	STUD, 5/16-18 x 2 in. long . . . . .	4	-

LYCOMING MODEL O-340 SERIES AIRCRAFT ENGINES

NUMERICAL PARTS LIST

Part Number	Part Name	No. Req'd.	
		MODEL A	B
67904	SEAT, Intake valve . . . . .	4	4
67905	VALVE, Intake . . . . .	4	4
67985	ELBOW ASSY, Spark plug (Packard type shielding only) . . . . .	8	8
68273	BRACKET, Generator (Req'd. with 24 volt 15 amp and 12 volt 35 amp generator) This bracket along with brace 69259, has been superseded by a strengthened bracket 69452, 69951 strut and 60733 shim. However, to employ these superseding parts the new starters 69952, 69953, or 71091 must be used whereby the generator may be tied to the starter.	1	-
68312	PLUNGER ASSY, Hydraulic tappet (Standard leak-down) . . . . .	8	8
68315	GASKET, Accessory drive adapter (Req'd. with propeller governor drive adapter. May not be used with 69106 cover)	1	-
68316	STUD, 5/16-18 x 1-11/16 in. long . . . . .	4	-
68317	SHAFTGEAR, Prop. governor drive . . . . .	1	-
68327	SEAT, Valve spring . . . . .	4	4
68336	SHIELDING ASSY, Ignition (Same as Breeze Corporation P/N E-3525) . . . . . Service parts for 68336 are: E-1018-41-1 Spark plug terminal E-1366-5-10 Lead assy, No. 1 and No. 3 top E-1366-5-20 Lead assy, No. 2 and No. 4 top E-1366-11-4308 Lead assy, No. 1 bottom E-1366-11-4100 Lead assy, No. 2 bottom E-1366-11-3708 Lead assy, No. 3 bottom E-1366-11-3600 Lead assy, No. 4 bottom 61559 Grommet, Ignition cable, 4 wire 61560 Plate, Ignition cable outlet 61572 Washer, Cable fastening 61573 Screw, Cable fastening 71401 Collar A recent design change replaces E-1018-41-1 with E-1018-47-1 and 71401 preventing moisture from reaching spark plug terminal, completely interchangeable.	1	-
68437	STUD, 5/16-18 x 1-7/8 in. long . . . . .	4	4
68486	FERRULE, Ignition cable, shielded (Packard type shielding) . . . . .	8	8
68487	NUT, Spark plug union (Packard type shielding only) . . . . .	8	8
68488	CABLE ASSY, Ignition shielded (Packard type) . . . . . Superseded by and interchangeable with 71491. Service in accordance with Service Letter of 9-20-57. Original 68488 assemblies incorporated terminal AN4164-1. Service AN4164-1 with 71401 collar and AN4164-2 terminal.	1	1

Consists of:

AR 1421-B	Cable	8	67985	Elbow
2 60670	Plate	8	68486	Ferrule
8 61558	Ferrule	8	68487	Nut
8 61563	Nut	8	71401	Collar

(Continued on following page)

LYCOMING MODEL O-340 SERIES AIRCRAFT ENGINES

NUMERICAL PARTS LIST

Part Number	Part Name	No. Req'd.	
		MODEL A	MODEL B
68488	(Continued from page 17) Consists of: 2 61565 Kit 8 AN4164-2 Sleeve 4 66216 Sleeve 4 STD958 Grommet		
68510	STUD, 1/4-20 x 1-1/16 in. . . . .	4	4
68513	RING, Piston, compression (Chrome plated) (Under no consideration may this ring be used with a chrome plated cylinder barrel)	8	8
68517	SPRING, Shroud tube . . . . .	8	8
68518	LOCKPLATE, Shroud tube . . . . .	4	4
68527	BEARING, Crankshaft - front (matched pair) (Alternate bearing is P/N 69372)	1	1
68531	ADAPTER ASSY, Prop. governor drive (Studded to receive an "AN" propeller governor) Consists of: 1 * 68472 Adapter 1 STD1774 Pin 4 68316 Stud	1	-
68532	TUBE ASSY, Prop. governor oil line . . . . .	1	-
68593	SPACER, Vacuum pump stud (Req'd. only when no vacuum pump is used) . .	4	4
68604	CLIP, 5/16 in. ID for 1/4 in. dia. screw (Cushion type) . . . . .	2	-
68613	SLINGER, Breather . . . . .	1	1
68626	REGULATOR, Voltage (Same as Delco Remy P/N 1119145) . . . . . For use with 12 volt 35 amp generator and 12 volt relay P/N 68628 in parallel system only.	1	-
68628	RELAY, Paralleling 12 volt (Same as Delco Remy P/N 1116887) . . . . . (1 req'd. for each twin engine installation when electrical system is in parallel)	1	-
68633	SHIELD, Accessory breather oil . . . . .	1	1
68634	HOUSING ASSY, Accessory (For details of this assy, refer to Figure 3) . .	1	-
68639	GEAR, Camshaft . . . . .	1	1
68668	SPRING, Oil pressure relief valve . . . . .	1	1
68700	BUSHING, Propeller flange (Used on crankshaft assy 69478 only) . . . . .	2	-
68710	PIN, Piston . . . . .	-	4
68749	SHAFT, Crankshaft idler gear . . . . .	2	2
68751	STUD, 1/2-20 x 10-21/32 long . . . . .	2	2
68753	SPACER, Tachometer shaft centering . . . . .	1	1
68757	SHAFT ASSY, Tachometer . . . . .	1	1
68758	TUBE, Accessory breather . . . . .	1	1
68759	TUBE ASSY, Cylinder head oil drain, cylinder No. 1 . . . . .	1	1

LYCOMING MODEL O-340 SERIES AIRCRAFT ENGINES

NUMERICAL PARTS LIST

Part Number	Part Name	No. Req'd.	
		MODEL A	MODEL B
68760	TUBE ASSY, Cylinder head oil drain, cylinder No. 2 . . . . .	1	1
68761	TUBE ASSY, Cylinder head oil drain, cylinders No. 3 and 4 . . . . .	2	2
68764	GENERATOR, 12 volt 20 amp (Same as Delco Remy P/N 1101899) . . . . .	1	-
68765	GENERATOR, 24 volt 15 amp (Same as Delco Remy P/N 1101901) . . . . .	1	-
68767	GENERATOR, 12 volt, 35 amp (Same as Delco Remy P/N 1101900) . . . . .	1	-
68769	CAMSHAFT ASSY . . . . .	1	1
	Consists of:		
	1 * 68768            Camshaft            1    STD1065            Dowel		
68866	BUSHING, Propeller flange (Tapped for 3/8 in. prop. attaching bolts) (Used on crankshaft assemblies, 71033 and 69478 only)	1	-
68867	SUPPORT ASSY, Starter ring gear . . . . .	1	1
	Consists of:		
	1 * 68506            Support            1    60882            Gear		
68870	BRACKET, Generator (Used with 24 volt 25 amp generator) . . . . .	1	-
68871	GENERATOR, 24 volt 25 amp (Same as Delco Remy P/N 1101905) . . . . .	1	-
68872	REGULATOR, Voltage (Same as Delco Remy P/N 1118799) (For use with 24 volt 25 amp generator)	1	-
68972	GASKET, Oil sump (Supersedes and interchangeable with 61382) . . . . .	1	1
68974	HOUSING, Oil pressure screen . . . . .	1	-
	(Machined to receive standard thermometer connection)		
69000	ADAPTER ASSY, Prop. governor drive (Studded to receive Woodward governor)	1	-
	Consists of:		
	1 * 68472            Adapter            1    STD1774            Pin		
	4    67556            Stud		
69097	TUBE, Oil level gage (Std) . . . . .	1	1
69098	TUBE, Oil level gage, long . . . . .	1	-
69106	COVER, Gov. drive adapter pad . . . . .	1	1
69113	BRACKET, Generator (Req'd. with 12 volt 20 amp generator) . . . . .	1	-
69116	GAGE ASSY, Oil level (long) . . . . .	1	-
69345	SPACER, Shroud tube spring . . . . .	4	4
69366	CARBURETOR (Same as Marvel-Schebler Carburetor assy. Model MA4-5, P/N 10-3810)	-	1
69370	SUMP ASSY, Oil . . . . .	1	1
	Consists of:		
	1 * 69369            Sump            2    61377            Connection		
	2    61376            Connection        4    68437            Stud		
69436	SPRING, Oil cooler by-pass (Not req'd. with thermostatic oil by-pass valve)	1	-

LYCOMING MODEL O-340 SERIES AIRCRAFT ENGINES

NUMERICAL PARTS LIST

Part Number	Part Name	No. Req'd. MODEL	
		A	B
69444	ROCKER ASSY, Valve . . . . . Consists of: 1 * 69443   Rocker       1   60398        Bushings	8	8
69451	VALVE ASSY, Temperature control oil cooler by-pass . . . . .	1	1
69452	BRACKET, Generator (Supersedes 68273) . . . . . (Req'd. with 24 volt 15 amp, 12 volt 35 amp generators and 12 volt 50 amp generators) See 68273 for interchangeability.	1	1
69456	PISTON . . . . .	-	4
69457	RING, Piston, oil regulating (Expander type) . . . . .	4	4
69459	BOLT, Connecting rod . . . . .	8	8
69460	NUT, Slotted 3/8-24 . . . . .	8	8
69467	ROD ASSY, Push (Short - 3 grooves) . . . . .	AR	AR
69468	ROD ASSY, Push (Medium - 2 grooves) . . . . .	AR	AR
69469	ROD ASSY, Push (Long - 1 groove) . . . . .	AR	AR
69469-1	ROD ASSY, Push (Extra long - no grooves) . . . . . A TOTAL OF 8 PUSH RODS REQ'D. PER ENGINE. SELECT FOR FIT.	AR	AR
69478	CRANKSHAFT ASSEMBLY (Provision for controllable pitch propeller) . . . . . Superseded by and differs from 71566 in that bushings 68866, 62530 and 68700 require 3/8 propeller attaching bolts. 71566 requires 7/16 in. prop. mounting bolts.  Consists of: 1 * 69445   Crankshaft   1 * 68484        Tube 4 * 69476   Tube         2   68700        Bushings 4   60449   Tube         1   68866        Bushings 1   61510   Plug         1   STD1065       Dowel 3   62530   Bushings    1   STD1211       Plug	1	-
69480	PIPE, Intake, No. 3 cylinder . . . . .	1	1
69481	PIPE, Intake, No. 4 cylinder . . . . .	1	1
69482	PIPE, Intake, No. 1 and 2 cylinders . . . . .	2	2
69483	ROD ASSY, Connecting . . . . . Consists of: 1 * 69461   Rod         1   65819        Bushings 2   69459   Bolt        2   69460        Nuts	4	4
69497	FUEL PUMP ASSEMBLY (Same as fuel pump P/N 62628 except 69497 incorporates a fuel inlet fitting P/N AN822-6-2D)	1	-
69510	HOUSING, Thermostatic valve and oil pressure screen . . . . .	1	1
69529	BODY, Hydraulic tappet . . . . .	8	8
69530	SEAT, Exhaust valve . . . . .	4	4
69531	PLATE, Cylinder hold-down nut . . . . .	8	8
69532	SEAT, Valve spring . . . . .	4	4
69533	GUIDE, Exhaust valve . . . . .	4	4



LYCOMING MODEL O-340 SERIES AIRCRAFT ENGINES

NUMERICAL PARTS LIST

Part Number	Part Name	No. Req'd. MODEL	
		A	B
69534	VALVE, Exhaust (Sodium cooled, rotator type)	-	4
69537	CRANKCASE ASSEMBLY, Machining (Superseded by 69819) Original crankcase has provisions for Lord or new type Lycoming mounting bushings. No provisions for "AN" type fuel pump drive. Provisions for direct drive starter. May be modified to receive geared starter by following instructions in Service Letter of 6-12-57.  This P/N represents the complete crankcase assy including studs, dowels, inserts, plugs, and retainers. Crankshaft bearings and the attaching parts for the crankcase halves are not part of the assy. For details of the above assy refer to Figure 2.	1	-
69538	CYLINDER AND HEAD ASSY (Plain) Consists of: 1 * 69536 Barrel 2 66796 Insert 1 * 71096 Head 1 67904 Seat 1 60028 Guide 1 68510 Stud 2 61261 Stud 1 69530 Seat 2 61262 Stud 1 69533 Guide 4 66610 Bushing 1 AN823-6D Elbow	4	4
69539	TUBE ASSY, Push rod shroud (Alternate is 69479)	8	8
69540	CARBURETOR (Same as Marvel-Schebler carburetor assy. Model MA4-5, P/N 10-3634)	1	-
69551	GASKET, Accessory drive adapter (Req'd. only when cover 68106 is used)	1	1
69590	PISTON (Superseded by 71594)	4	-
69650	PIN, Piston	4	-
69666	BAFFLE ASSY, Intercylinder	2	2
69675	CONNECTOR, Accessory housing to oil cooler inlet hose (Req'd. with thermostatic oil by-pass valve)	1	1
69787	HOUSING ASSY, Accessory (For details of this assy, refer to Figure 3)	-	1
69819	CRANKCASE ASSEMBLY, Machining (Supersedes and differs from 69537 only in that 69819 has provision for an AN type fuel pump. Has provisions for Lord or new type Lycoming mounting bushings. Has provisions for an "AN" type fuel pump drive. May be modified to receive geared starter by following instructions in Service Letter dated 6-12-57.  This P/N represents the complete crankcase assy including studs, dowels, inserts, plugs, and retainers. Crankshaft bearings and the attaching parts for the crankcase halves are not part of the assy. For details of the above assy, refer to figure 2.	-	1
69836	BUSHING, Propeller flange (Tapped for 7/16 in. propeller attaching bolts) Crankshaft Assy 71566 Crankshaft Assy 71567	3 5	3 5

LYCOMING MODEL O-340 SERIES AIRCRAFT ENGINES

NUMERICAL PARTS LIST

Part Number	Part Name	No. Req'd.	
		MODEL A	B
69837	BUSHING, Propeller flange (Controllable pitch propeller only) . . . . . (Supersedes 68700 which was used on crankshaft assy 69478) (Crankshaft assy P/N 71566 only)	2	-
69838	BUSHING, Propeller flange (Tapped for 7/16 in. prop. attaching bolts) . . . . . (Supersedes 68866 which were used on crankshaft assemblies 71033 and 69478)	1	1
69951	STRUT, Generator support . . . . . For use with 69952, 69953 and 71091 starters only. Cannot be used with 60849 or 62714 starters.	1	-
69952	STARTER, 12 Volt (Supersedes 60849) (Same as Delco Remy Model 1109657) . . . . . (See 60849 for interchangeability)	1	1
69953	STARTER, 24 Volt (Supersedes 62714) (Same as Delco Remy Model 1109669) . . . . . (See 62714 for interchangeability)	1	1
69961	BEARING, Crankshaft . . . . .	4	4
70310	SEAL, Shroud tube . . . . .	8	8
71032	BUSHING, Engine support . . . . .	8	8
71033	CRANKSHAFT ASSEMBLY (Provision for fixed pitched propeller) . . . . . Superseded by and differs from 71567 in that propeller attaching bolts are 3/8 in. which require bushings 62530 and 68866.  Consists of: 1 * 69445      Crankshaft      1 * 68484      Tube 4 * 69476      Tube              1    68866      Bushing 4    60449      Tube              1    STD1065      Dowel 5    62530      Bushing          1    STD1211      Plug	1	-
71091	STARTER, 12 Volt, internal reduction (Same as Delco Remy P/N 1109673) . . . . . This starter is interchangeable with starter P/N 69952. However, the mounting differs. For details of both mountings, refer to Attaching Parts Section and the applicable illustration in the Illustrated Parts Section.	1	-
71133	NUT, Allen hd. 1/2-20 NF-3 . . . . .	16	16
71134	NUT, Allen hd. 3/8-24 NF-3 . . . . .	16	16
71258	FERRULE, Shield terminator braid confining (Packard type only) . . . . .	16	16
71259	SLEEVE, Shield terminator insulation support (Packard type only) . . . . .	16	16
71397	MAGNETO (Impulse coupling) (Same as Scintilla type S4LN-21, P/N 10-51360-24) . . . . . (Supersedes and interchangeable with 61667)	1	-
71398	MAGNETO (Same as Scintilla type S4LN-20 P/N 10-51360-23) (Supersedes and interchangeable with 61502)	1	-
71401	COLLAR, Spark plug terminal . . . . .	8	8
71432	MAGNETO (35° lag angle) (Impulse coupling) (Same as Scintilla type S4LN-21, P/N 10-51360-25)	-	2
71481	RING, Oil seal, 3/32 dia. section x 4-27/32 ID (Supersedes 67498) . . . . .	4	4

**LYCOMING MODEL O-340 SERIES AIRCRAFT ENGINES**

**NUMERICAL PARTS LIST**

Part Number	Part Name	No. Req'd.	
		MODEL A	B
71488	WASHER, Shield terminator mag. adapting (Packard type only) . . . . .	8	8
71489	SLEEVE, Spark plug terminal (Packard type only) . . . . .	8	8
71491	CABLE ASSY, Ignition shielded (Packard type) (Supersedes and interchangeable with 68488)	1	1
	Consists of:		
	AR 1421-B Cable 16 71259 Sleeve		
	2 60670 Plate 8 71401 Collar		
	8 61563 Nut 8 71488 Washer		
	2 61565 Kit 8 71489 Sleeve		
	4 66216 Sleeve 8 71495 Elbow Assy		
	8 68487 Nut 4 STD958 Grommet		
	16 71258 Ferrule		
71495	ELBOW ASSY, Spark plug (For Packard shielding only) . . . . .	8	8
71537	FUEL PUMP ASSEMBLY (Same as fuel pump P/N 62628 except 71537 incorporates a fuel inlet fitting P/N AN822-4D)	1	-
71566	CRANKSHAFT ASSEMBLY (Provisions for controllable pitch propeller and 7/16 in. attaching bolts) (Supersedes 69478) See 69478 for interchangeability.	1	-
	Consists of:		
	1 * 69445 Crankshaft 3 69836 Bushing		
	4 * 69476 Tube 2 69837 Bushing		
	4 60449 Tube 1 69838 Bushing		
	1 61510 Plug 1 STD1065 Dowel		
	1 * 68484 Tube 1 STD1211 Plug		
71567	CRANKSHAFT ASSEMBLY (Provisions for fixed pitch propeller and 7/16 in. attaching bolts) (Supersedes 71033) See 71033 for interchangeability	1	1
	Consists of:		
	1 * 69445 Crankshaft 5 69836 Bushing		
	4 * 69476 Tube 1 69838 Bushing		
	4 60449 Tube 1 STD1065 Dowel		
	1 * 68484 Tube 1 STD1211 Plug		
71588	CRANKCASE ASSEMBLY, Machining . . . . . Current crankcase has provisions for Lord or new type Lycoming mounting bushings. Provisions for an "AN" type fuel pump drive. Studded to receive geared starter. Alternate to 69819.	1	-
71594	PISTON (Supersedes and interchangeable with 69590) (Same as 69590 except piston is anodized)	4	-
71595	VALVE, Exhaust (Sodium cooled, rotator type) (Supersedes and interchangeable with 69534. 71595 is made of improved material to prevent corrosion)	4	-
71596	WASHER, Accessory driven gear (Supersedes and interchangeable with P/N 60869)	2	-
71714	PLUG, Oil relief valve (Supersedes and interchangeable with 61143) . . . . .	1	1
71744	GENERATOR, 12 volt 50 amp (Same as Delco Remy P/N X-2679) . . . . .	1	1
71745	REGULATOR, Voltage (Same as Delco Remy P/N 1118713) (For use with 12 volt 50 amp generator)	1	1

LYCOMING MODEL O-340 SERIES AIRCRAFT ENGINES

NUMERICAL STANDARD PARTS LIST

Part Number	Part Name	No. Req'd.	
		MODEL A	MODEL B
AN365-632C	NUT, Self locking, No. 6-32 . . . . .	7	7
AN456AD4-8	RIVET, Brazier hd. 1/8 dia. x 1-1/2 in. . . . .	2	2
AN500-416-12	SCREW, Fillister head 1/4-20 x 3/4 in. long . . . . .	2	2
AN816-5-4D	NIPPLE, 5/16 flared tube, 1/4 in. NPT . . . . .	1	-
AN822-4D	ELBOW, 1/4 flared tube x 1/8 pipe thread - 90° . . . . .	1	-
AN822-5-4D	ELBOW, 5/16 in. flared tube and 1/4 in. NPT - 90° . . . . . (Assemble in right crankcase, front) (Req'd. when propeller governor oil line is used)	1	-
AN822-6-2D	ELBOW, 3/8 flared tube x 1/8 pipe thread - 90° . . . . .	1	-
AN823-6D	ELBOW, 3/8 in. flared tube x 45° . . . . .	4	4
AN4076-1	FITTING, Temp. measuring element . . . . .	1	1
AN4164-2	SLEEVE, Spark plug (AN4164-2 along with 71401 supersedes 235) . . . . .	8	8
AN5541-1	THERMOCOUPLE, Cylinder head bayonet type . . . . .	1	1
STD8	WASHER, Plain 1/4 in. . . . .	86	86
STD28	WASHER, Plain, No. 10 . . . . .	4	4
STD33	WASHER, Plain 3/8 in. . . . .	14	14
STD35	WASHER, Plain 5/16 in. . . . .	24	24
STD47	PLUG, Allen, 1/4 in. pipe . . . . . (1 req'd. in right crankcase when no propeller governor oil line is used)	2	2
STD68	PIN, Cotter, .06 dia. x 1/2 in. long . . . . .	7	5
STD160	WASHER, Shakeproof lock 1/4 in. . . . .	62	62
STD178	WASHER, Spring lock No. 10 . . . . .	8	-
STD208	SEAL, Oil 51/64 ID x 1-1/2 OD x 1/8 in. wide . . . . .	1	-
STD243	WASHER, Plain No. 6 . . . . .	4	4
STD294	GASKET, Annular 7/8 OD x 5/8 x 3/32 . . . . .	3	3
STD336	RING, Oil seal, .47 ID x 3/32 in. . . . .	6	6
STD347	HOSE, 3/8 ID x 1-13/16 in. long . . . . .	4	4
STD475	WASHER, Shakeproof lock 5/16 in. . . . .	24	24
STD514	DOWEL, 5/16 dia. x 1/2 in. long . . . . .	2	2
STD543	PIN, Cotter 3/32 dia. x 5/8 in. . . . .	8	8
STD546	NIPPLE, Primer . . . . .	3	3
STD551	PLUG, 1/2 in. pipe, sq. hd. dr. . . . .	1	1

LYCOMING MODEL O-340 SERIES AIRCRAFT ENGINES

NUMERICAL STANDARD PARTS LIST

Part Number	Part Name	No. Req'd.	
		MODEL A	B
STD553	SCREW, Rd. head, 6-32 x 1/2 in. long . . . . .	7	7
STD557	DOWEL, Hollow 1/2 dia. x 11/16 in. long . . . . .	2	2
STD596	NUT, Plain 3/8-24 . . . . .	2	2
STD599	SCREW, Rd. hd., No. 2 self-tapping . . . . .	4	4
STD619	WASHER, 17/32 ID x 1-3/4 x 5/32 in. . . . .	8	8
STD670	NUT, Self-locking, No. 10-32 . . . . .	2	2
STD678	WASHER, Shakeproof lock 3/8 in. . . . .	2	2
STD684	NIPPLE, Straight 3/8 ID hose . . . . .	4	4
STD705	SCREW, Hex hd. 1/4-20 x 11/16 in. long . . . . .	4	4
STD713	PIN, Cotter 3/32 dia. x 3/4 in. . . . .	1	1
STD714	PIN, Cotter 1/8 dia. x 1 in. long . . . . .	1	1
STD784	PLUG, 3/8 in. Allen hd. pipe . . . . .	2	1
STD847	SCREW, 5/16-24 x 1 in. . . . .	1	1
STD853	TEE, Union, 1/8 in. tube . . . . .	2	2
STD860	SCREW, Fillister head, No. 10-32 x .63 in. long . . . . .	8	-
STD872	NUT, Slotted 3/8-24 . . . . .	1	1
STD958	GROMMET, 3/8 in. ID (Packard type shielding only) . . . . .	4	-
STD998	RING, Oil seal, 23/64 ID x .10 in. section . . . . .	2	2
STD1045	GASKET, 1-1/4 ID x 1-1/2 x 3/32 in. annular . . . . .	2	2
STD1065	DOWEL, Stepped .310-.251 dia. x 35/64 in. . . . .	2	2
STD1196	HOSE, 1-1/2 ID x 1-7/8 OD x 1-1/2 long . . . . .	4	4
STD1197	BOLT, Hex hd. 3/8-24 x 3-1/2 in. long . . . . .	2	2
STD1199	PIN, 3/16 dia. x 1.13 in. long . . . . .	1	1
STD1202	BOLT, Hex head 5/16-18 x 1-3/32 long . . . . .	4	-
STD1204	BOLT, Hex hd. 1/4-20 x 15/16 in. long . . . . .	32	32
STD1205	BOLT, Hex hd. 3/8-24 x 2.19 in. long, dr. . . . .	1	1
STD1211	PLUG, Expansion 2 in. dia. . . . . Must be removed from crankshaft assy when in- stalling controllable pitch propeller.	1	1
STD1215	BOLT, Hex hd. 1/4-20 x 1-1/4 in. long . . . . .	2	2
STD1221	RING, External retaining, 13/16 dia. x 3/64 thick . . . . .	1	-
STD1227	WASHER, Plain 1/4 in. . . . .	2	2

LYCOMING MODEL O-340 SERIES AIRCRAFT ENGINES

NUMERICAL STANDARD PARTS LIST

Part Number	Part Name	No. Req'd.	
		MODEL A	MODEL B
STD1252	CLAMP, Hose 3/4 ID x 9/16 in. wide . . . . .	8	8
STD1409	NUT, Slotted shear 1/4-20 . . . . .	5	5
STD1410	NUT, Plain 5/16-18 . . . . .	27	27
STD1411	NUT, Plain 1/4-20 . . . . .	38	38
STD1414	BOLT, Hex hd. 1/4-20 x 1-1/2 in. . . . .	8	8
STD1415	BOLT, Hex hd. 1/4-20 x 1-3/4 in. long . . . . .	3	3
STD1416	BOLT, Hex hd. 1/4-20 x 1-1/2 dr. . . . .	3	3
STD1420	NUT, Slotted 5/16-18 . . . . .	5	3
STD1433	BOLT, Hex hd. 1/4-20 x 1-1/2 in. long (dr. end) . . . . .	2	2
STD1434	CLAMP, Hose 2 ID x 1/2 wide (Domestic shipment only) . . . . .	8	8
STD1592	BOLT, Hex hd., drilled hd. 3/8-16 x 3/4 in. . . . .	2	2
STD1623	INSERT, Helicoll 1/4-20 x 3/8 in. long (Notched) . . . . .	2	2
STD1727	WASHER, Plain 3/4 OD x 21/64 ID x 1/8 . . . . .	5	4
STD1763	LOCKNUT, 5/16 in. (Palnut) . . . . .	4	4
STD1774	PIN, 1/8 dia. x 1/4 in. long . . . . .	1	-
STD1791	BOLT, Hex hd. 5/16-24 x 21/32 in. long . . . . .	4	4
STD1807	SCREW, Long socket head, dr. hd. 3/8-16 x 3-1/4 in. lg. . . . .	2	-
STD1817	BOLT, Hex head dr. 5/16-18 x 3/4 in. long . . . . .	3	-
STD1826	SCREW, Fillister hd. self locking 1/4-20 x 5/8 in. . . . .	24	24
STD1831	CLAMP, Hose 2 ID x 5/8 in. wide (For export shipment only) . . . . .	8	-
STD1834	BOLT, Hex hd., dr. end 5/16-18 x 1-1/16 in. long . . . . .	1	-
STD1835	BOLT, Hex hd. dr. end 5/16-18 x 1-23/64 in. long . . . . .	1	-

LYCOMING MODEL O-340 SERIES AIRCRAFT ENGINES

NUMERICAL OVERSIZE AND UNDERSIZE PARTS SECTION

The following is a listing of parts that may be procured in sizes other than standard and an explanation of the oversize and undersize symbols.

The symbol "P" suffixed to the standard size part number indicates the part may be procured in oversize; the symbol "M" indicates undersize. The numerals 03, 10, 12, 20, etc., following the symbol "P" or "M" indicate the extent of deviation from standard, in thousandths of an inch, in oversize or undersize.

Example A: 66610-P10 indicates 66610 may be procured in .010 oversize.

Example B: 69961-M03 indicates 69961 may be procured in .003 undersize.

<u>Part Number</u>	<u>Part Name</u>	<u>Undersize or Oversize Available</u>
-----	Bearings - Rod and Crankshaft . . . . .	M03-M10
-----	Guide - Valve . . . . .	P05-P10-P20-P30
-----	Piston . . . . .	P10-P20
-----	Rings - Piston . . . . .	P10-P20
-----	Seats - Valve . . . . .	P10-P20-P30-P50
-----	Studs . . . . .	P03-P07-P12
62530	Bushing - Propeller Flange . . . . .	P05-P10-P20
66610	Bushing - Rocker Shaft . . . . .	P05-P10
68700	Bushing - Propeller Flange . . . . .	P05-P10-P20
68866	Bushing - Propeller Flange . . . . .	P05-P10-P20
69836	Bushing - Propeller Flange . . . . .	P05-P10-P20
69837	Bushing - Propeller Flange . . . . .	P05-P10-P20
69838	Bushing - Propeller Flange . . . . .	P05-P10-P20

LYCOMING MODEL O-340 SERIES AIRCRAFT ENGINES

SERVICE REPLACEMENT SET SECTION

Part Number

Part Name

69371

SEAL AND GASKET SET

Consisting of:

1	STD208	Seal, Oil
2	STD294	Gasket, Annular
6	STD336	Seal, Oil
1	STD548	Seal, Oil
2	STD998	Ring, Oil seal
2	STD1045	Gasket, Annular
8	STD1760	Ring, Oil seal
1	179-B	Gasket, Governor drive
1	8313	Gasket, Vacuum pump
2	45663	Gasket, Magneto
16	60053	Seal, Shroud tube
1	60096	Gasket, Fuel pump
4	60131	Gasket, Intake flange
1	60592	Gasket, Carburetor
1	60734	Seal, Crankshaft oil
1	60820	Gasket, Oil suction tube flange
2	60895	Gasket, Oil level gage
2	61165	Seal, Tachometer shaft
2	61173	Gasket, Oil pressure housing
1	61183	Gasket, Accessory adapter
4	61246	Gasket, Rocker box cover
1	61352	Gasket, Accessory housing
1	61531	Gasket, Hydraulic valve
2	62224	Gasket, Magneto adapter
4	65321	Gasket, Exhaust flange
1	66224	Gasket, Carburetor
1	68315	Gasket, Accessory drive adapter
1	68972	Gasket, Oil sump
1	69551	Gasket, Accessory pad cover
1	69643	Gasket, Application List
1	69720	Gasket, Dual accessory drive adapter cover
1	69723	Gasket, Governor
1	69827	Gasket, Governor spacer
8	70310	Seal, Shroud tube
4	71481	Seal, Oil
1		Container

69829

CYLINDER, PISTON AND RING ASSY (Plain barrel, all chrome plated piston rings) O-340-A

Consisting of:

1	STD1411	Nut, Plain 1/4-20
6	STD1826	Screw
2	60009	Key, Valve
2	60053	Seal, Shroud tube
1	60401	Shaft, Valve rocker
2	60828	Plug, Piston pin
1	61246	Gasket, Rocker box cover
1	61247	Cover, Rocker box
2	62387	Key, Valve
1	62388	Cap, Valve stem
2	65427	Spring, Valve outer
2	65441	Seal, Valve spring, lower
2	65567	Spring, Valve auxiliary
1	67905	Valve, Intake
1	68327	Seat, Valve spring
2	68513	Ring, Piston, top and second compression
2	68517	Spring, Shroud tube
1	68518	Lockplate, Shroud tube
1	69345	Spacer, Shroud tube spring
2	69444	Rocker assy, Valve



LYCOMING MODEL O-340 SERIES AIRCRAFT ENGINES

SERVICE REPLACEMENT SET SECTION

<u>Part Number</u>	<u>Part Name</u>
69829	CYLINDER, PISTON AND RING ASSY - O-340-A (Cont) Consisting of: 1 69457 Ring, Piston, oil regulating, expander type 1 69532 Seat, Valve spring 1 69538 Cylinder and head assy 1 69650 Pin, Piston 2 70310 Seal, Shroud tube 1 71481 Ring, Oil seal 1 71594 Piston 1 71595 Valve, Exhaust (rotator type)
71872	CYLINDER, PISTON AND RING ASSY (Plain barrel, all chrome plated piston rings) O-340-B Consisting of: 1 STD1411 Nut, Plain 1/4-20 6 STD1826 Screw 2 60009 Key, Valve 2 60053 Seal, Shroud tube 1 60401 Shaft, Valve rocker 2 60828 Plug, Piston pin 1 61246 Gasket, Rocker box cover 1 61247 Cover, Rocker box 2 62387 Key, Valve 1 62388 Cap, Valve stem 2 65427 Spring, Valve outer 2 65441 Seat, Valve spring, lower 2 65567 Spring, Valve auxiliary 1 67905 Valve, Intake 1 68327 Seat, Valve spring 2 68513 Ring, Piston, top and second compression 2 68517 Spring, Shroud tube 1 68518 Lockplate, Shroud tube 1 68710 Pin, Piston 1 69345 Spacer, Shroud tube spring 2 69444 Rocker assy, Valve 1 69456 Piston 1 69457 Ring, Piston, oil regulating, expander type 1 69532 Seat, Valve spring 1 69534 Valve, Exhaust (rotator type) 1 69538 Cylinder and head assy 2 70310 Seal, Shroud tube 1 71481 Ring, Oil seal

LYCOMING MODEL O-340 SERIES AIRCRAFT ENGINES

ATTACHING PARTS SECTION

Part Name	No. Req'd.	Part Name	No. Req'd.
<b>ADAPTER ASSY, Propeller governor drive</b>		<b>CRANKCASE HALVES (Continued)</b>	
STD35 Washer	4	STD596 Nut	2
STD475 Washer	4	STD1414 Bolt	8
STD1410 Nut	4	STD1416 Bolt	3
<b>BAFFLE ASSY, Intercylinder</b>		STD8 Washer	22
65883 Clamp	1	STD1415 Bolt	1
1892 Spring	1	STD160 Washer	9
STD28 Washer	2	STD1411 Nut	9
STD670 Nut	1	STD1409 Nut	3
<b>BRACKET, Generator</b>		STD68 Pin	3
STD8 Washer	1	STD1205 Bolt	1
STD160 Washer	3	STD872 Nut	1
STD1415 Bolt	1	STD713 Pin	1
STD1215 Bolt	2	<b>CYLINDER ASSY</b>	
STD1411 Nut	1	69531 Plate	2
(For brackets 69452 and 68870 only, 60733 shims as req'd. for end clearance)		71133 Nut	4
<b>CARBURETOR</b>		71134 Nut	4
STD35 Washer	4	STD1823 Lockwire	AR
STD1410 Nut	4	<b>FLANGE, Exhaust</b>	
STD1763 Locknut	4	STD35 Washer	2
<b>CLAMP, Primer line</b>		STD475 Washer	2
STD553 Screw	1	STD1410 Nut	2
AN365-632C Nut	1	<b>FLANGE, Intake pipe</b>	
<b>CONNECTING ROD CAP</b>		STD8 Washer	2
69459 Bolt	2	STD160 Washer	2
69460 Nut	2	STD1411 Nut	2
STD543 Pin	2	<b>FUEL PUMP</b>	
<b>COVER, Fuel pump</b>		STD33 Washer	2
STD33 Washer	2	STD1807 Screw	2
STD1592 Bolt	2	<b>GEAR, Camshaft</b>	
<b>COVER, Governor drive</b>		66144 Lockplate	2
STD35 Washer	32	STD1791 Bolt	4
STD475 Washer	4	<b>GEAR, Crankshaft</b>	
STD1410 Nut	4	61156 Lockplate	1
<b>COVER, Governor drive adapter pad</b>		STD647 Screw	1
STD35 Washer	4	<b>GENERATOR</b>	
STD475 Washer	4	STD1727 Washer	1
STD1410 Nut	4	STD1834 Bolt	1
<b>COVER, Rocker box</b>		STD1835 Bolt	1
STD1826 Screw	6	STD35 Washer	AR
<b>COVER, Vacuum pump</b>		STD1420 Nut	2
68593 Spacer	4	STD68 Pin	2
STD8 Washer	4	<b>HOUSING, Accessory</b>	
STD160 Washer	4	STD8 Washer	12
STD1411 Nut	4	STD160 Washer	12
<b>CRANKCASE HALVES</b>		STD1204 Bolt	10
STD1197 Bolt	2	STD1415 Bolt	2
STD33 Washer	6	<b>HOUSING, Oil pressure screen</b>	
STD678 Washer	2	STD8 Washer	3
(Continued next column)		STD1204 Bolt	4
		STD160 Washer	4

LYCOMING MODEL O-340 SERIES AIRCRAFT ENGINES

ATTACHING PARTS SECTION

<u>Part Name</u>		<u>No. Req'd.</u>	<u>Part Name</u>		<u>No. Req'd.</u>
LINK, Generator adjusting			STARTER (71091 only)		
STD35	Washer	1	STD35	Washer	4
STD1817	Bolt	2	STD475	Washer	4
MAGNETO			STD1202	Bolt	1
STD1727	Washer	2	STD1410	Nut	3
STD475	Washer	2	STRUT, Generator support		
STD1410	Nut	2	STD1817	Bolt	1
NAMEPLATE			SUMP, Oil		
STD599	Screw	4	STD8	Washer	32
SHAFT, Crankshaft idler gear			STD160	Washer	20
61864	Lockplate	1	STD1204	Bolt	18
STD705	Screw	2	STD1411	Nut	14
SPRING, Shroud tube			TUBE ASSY, Propeller governor oil line		
68518	Lockplate	1	68604	Clip	2
STD1411	Nut	1	VACUUM PUMP		
STARTER (All but 71091)			STD8	Washer	4
STD35	Washer	4	STD160	Washer	4
STD475	Washer	4	STD1411	Nut	4
STD1202	Bolt	4			