



652 Oliver Street  
Williamsport, PA. 17701 U.S.A.

Telephone +1 (800) 258-3279 U.S. and Canada (Toll Free)  
Telephone +1 (570) 323-6181 (Direct)  
Facsimile +1 (570) 327-7101

www.lycoming.com

# SERVICE INSTRUCTION

DATE: February 05, 2018

Service Instruction No. 1514D  
(Supersedes Service Instruction No. 1514C)  
Engineering Aspects are  
FAA Approved

SUBJECT: Roller Tappets Part Information Update

MODELS AFFECTED: Lycoming new, rebuilt and overhauled 4 and 6 cylinder aircraft engines with the new roller tappet configuration

TIME OF COMPLIANCE: Whenever the new roller tappet engines are serviced

REASON FOR REVISION: Removed shroud tube springs from Tables 1 and 2; update to Figure 1; P/N updates on page 2

**NOTICE:** Incomplete review of all the information in this document can cause errors. Read the entire Service Instruction to make sure you have a complete understanding of the requirements.

As a product improvement, Lycoming is installing roller tappets on its aircraft engines. Wide deck engines with roller tappets are identified with an “E” suffix after the serial number dash number (Example – L-\*\*\*\*\*-48E.) On rebuilt and Lycoming overhauled wide deck engines with roller tappets, the letter “A” suffix is replaced with the letter “E” suffix on the engine serial number.

The new parts include roller tappet body assembly, crankcase, camshaft, shorter push rods, shroud tubes and shroud tube seal. The engines use the same hydraulic units and the dry tappet clearance does not change. Refer to Reference 618 in the Table of Limits (SSP-1776) for dry tappet clearance values.

**NOTICE:** At this time, roller tappets are not installed in narrow deck engines.

**WARNING:** ROLLER TAPPET PARTS ARE NOT INTERCHANGEABLE WITH CURRENT FLAT FACED TAPPETS.

If it is necessary to remove the roller tappet bodies prior to overhaul, they **must be reinstalled in the same location in the crankcase.** The roller tappets are indexed with flats in the new crankcase. It is possible to assemble the roller tappet bodies in two different orientations 180 degrees apart. Either orientation is acceptable while reinstalling. Lubricate all tappet bores, cam lobes and roller tappets with engine oil mixture only. (Refer to the latest revision of Service Instruction No. 1059.) Install the shroud tube seal in the crankcase, then install the shroud tube.

**WARNING:** THE ROLLER TAPPETS ARE NOT FIELD REPAIRABLE AND NO DISASSEMBLY IS ALLOWED. THEREFORE, MAGNAFLUX OR ZYGLO INSPECTIONS ARE NOT ALLOWED. A VISUAL INSPECTION FOR INTEGRITY AND FREE ROTATION OF THE ROLLER ACTION IS ACCEPTABLE TO RETURN AN IN-USE ROLLER TAPPET TO SERVICE; HOWEVER, IT IS MANDATORY TO REPLACE ROLLER TAPPETS AT OVERHAUL.



ISSUED			REVISED			PAGE NO.	REVISION
MO	DAY	YEAR	MO	DAY	YEAR		
03	10	06	02	05	18	1 of 4	D

**In the event the engine is disassembled for a propeller strike or sudden engine stoppage as defined in the latest revision of Service Bulletin No. 533, all of the roller tappet body assemblies P/N, LRT23381, must be replaced.**

Following is a list of push rod assemblies that are employed on 4 and 6 cylinder roller tappet engines only. These push rods are not to be used on non-roller tappet engines.

15F28835-08	15F28835-30	15F28835-43	15F28835-59	15F28864-10
15F28835-09	15F28835-31	15F28835-44	15F28835-60	15F28864-14
15F28835-10	15F28835-32	15F28835-52	15F28835-61	15F28864-17
15F28835-28	15F28835-33	15F28835-53	15F28864-08	15F28864-18
15F28835-29	15F28835-42	15F28835-54	15F28864-09	

Refer to the latest revision of Service Instruction No. 1060 for a complete listing of push rod assemblies.

Following is a list of the parts, roller tappet part numbers and flat tappet part numbers for four-cylinder aircraft engines. (Refer to illustration.)

**Table 1  
Part Numbers for Lycoming Four-Cylinder Engines**

Item No.	Current Flat Tappet P/N	New Superseding Roller Tappet P/N	Description
1	LW-18840	15M23452	Camshaft Assy.
1	LW-18845	15M23454	Camshaft Assy. (Left-Hand Engine Rotation)
1	LW-18843	15M23456	Camshaft Assy.
1	15M19407	15M23496	Camshaft Assy. (Left-Hand Engine Rotation)
2	66728	01L23459	Washer, .78 ID x 1-3/8 OD x .041
3	72877	LRT23381	Body Assy., Hydraulic Tappet Roller
4	LW-18661	06A23493	Seal, Shroud Tube
5	LW-11485	15G23461	Shroud Tube
5	72255	15G23462	Shroud Tube
5	68987	15G23494	Shroud Tube
6	LW-13823-1	LW-13823-5	Crankcase Assy.
6	LW-18399-1	LW-18399-5	Crankcase Assy.
6	LW-18402-2	LW-18402-5	Crankcase Assy.
6	LW-18770-1	LW-18770-5	Crankcase Assy.
6	11B19524-1	11B19524-5	Crankcase Assy.
6	11B20061-1SL	11B20161-1SL	Crankcase Assy.
6	11B20061-1SH	11B20161-1SH	Crankcase Assy.
6	11B20061-1SB	11B20161-1SB	Crankcase Assy.
6	11B20061-1DL	11B20161-1DL	Crankcase Assy.
6	11B20061-2SL	11B20161-2SL	Crankcase Assy.
6	11B20061-3SL	11B20161-3SL	Crankcase Assy.
6	11B20061-3SH	11B20161-3SH	Crankcase Assy.
6	11B20061-3SB	11B20161-3SB	Crankcase Assy.
6	11D22549	11D28751-1S3	Crankcase Assy.
6	11D22560	11D22560-5	Crankcase Assy.

ISSUED			REVISED			PAGE NO.	REVISION	S.I. 1514
MO	DAY	YEAR	MO	DAY	YEAR			
03	10	06	02	05	18	2 of 4	D	

Following is a list of the parts, roller tappet part numbers and flat tappet part numbers for six-cylinder aircraft engines. (Refer to illustration.)

**Table 2  
Part Numbers for Lycoming Six-Cylinder Engines**

<b>Item No.</b>	<b>Current Flat Tappet P/N</b>	<b>New Superseding Roller Tappet P/N</b>	<b>Description</b>
1	LW-19340	15N23374	Camshaft Assy.
1	-----	15N26092	Camshaft - No Tach Shaft (Roller Lifter)
2	66728	01L23459	Washer, .78 ID x 1-3/8 OD x .041
3	72877	LRT23381	Body Assy., Hydraulic Tappet Roller
4	LW-18661	06A23493	Seal, Shroud Tube
5	LW-11485	15G23461	Shroud Tube
5	LW-18944	15G23487	Shroud Tube
5	72255	15G23462	Shroud Tube
5	72257	15G23948	Shroud Tube
6	11E24000-D1	11E24100-D1	Crankcase Assy.
6	11E24000-D2	11E24100-D2	Crankcase Assy.
6	11E24000-S1	11E24100-S1	Crankcase Assy.
6	11E24000-S3	11E24100-S3	Crankcase Assy.
6	11E24000-S4	11E24100-S4	Crankcase Assy.
6	11E24001-S1	11E24101-S1	Crankcase Assy.
6	11E24001-S4	11E24101-S4	Crankcase Assy.
6	11E24005-S1	11E24105-S1	Crankcase Assy.
6	-----	11E24106-S1 ▲	Crankcase Assy.
6	11F24020-D1	11F24120-D1	Crankcase Assy.
6	11F24020-S1	11F24120-S1	Crankcase Assy.
6	11F24020-S3	11F24120-S3	Crankcase Assy.
6	11F24020-S8	11F24120-S8	Crankcase Assy.
6	11F24023-S3	11F24123-S3	Crankcase Assy.
6	11F24023-S6	11F24123-S6	Crankcase Assy.
6	11F24024-S7	11F24124-S7	Crankcase Assy.
6	11T25020-S1	11T25120-S1	Crankcase Assy.
▲ 11E24106-S1 replaces 11E24104-S1 which is no longer available.			

ISSUED			REVISED			PAGE NO.	REVISION	S.I. 1514
MO	DAY	YEAR	MO	DAY	YEAR	3 of 4	D	
03	10	06	02	05	18			

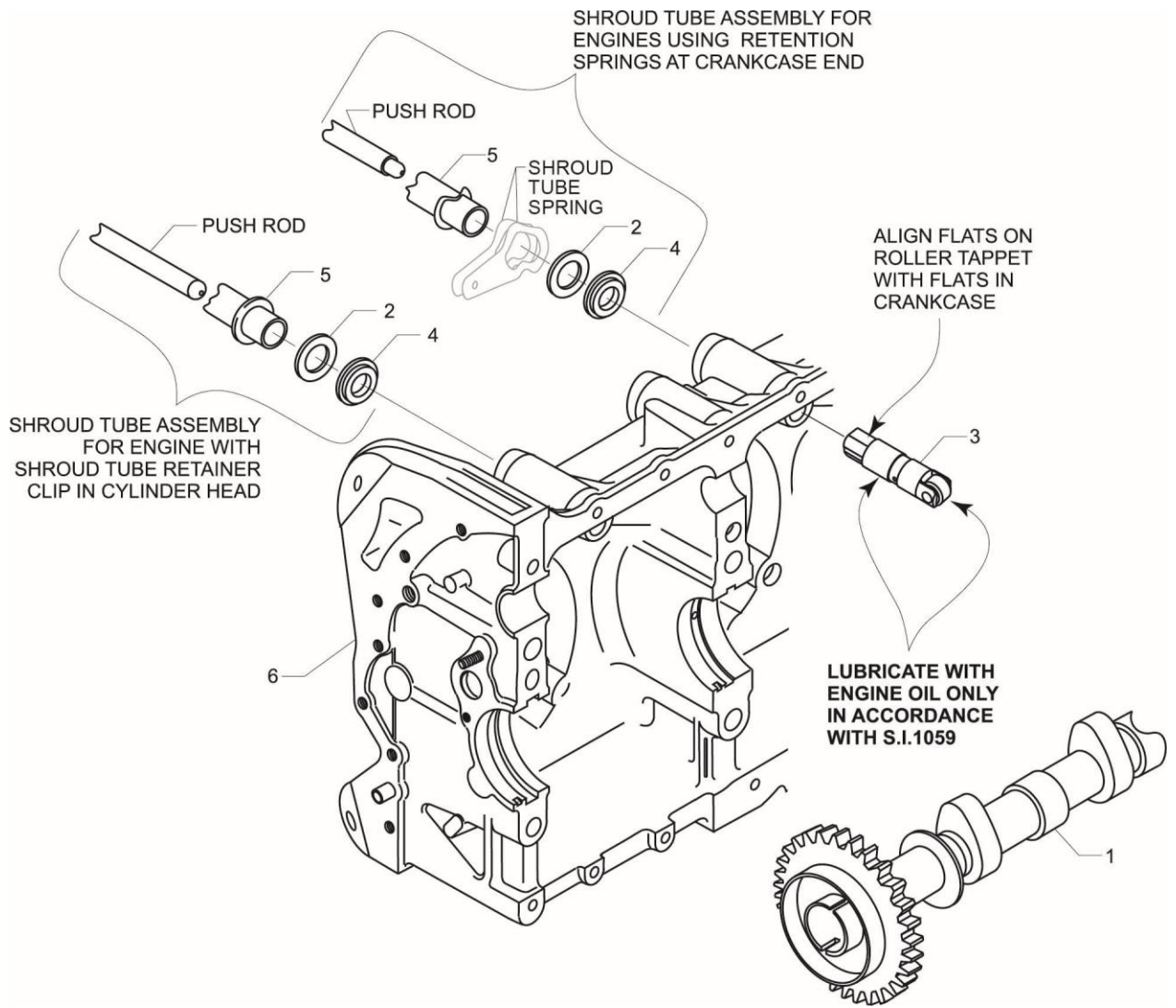

**Figure 1**  
**Roller Tappet Assemblies**

ISSUED			REVISED			PAGE NO.	REVISION	S.I. 1514
MO	DAY	YEAR	MO	DAY	YEAR			
03	10	06	02	05	18	4 of 4	D	